

**ROLLON**<sup>®</sup>  
BY TIMKEN

*Smart System*

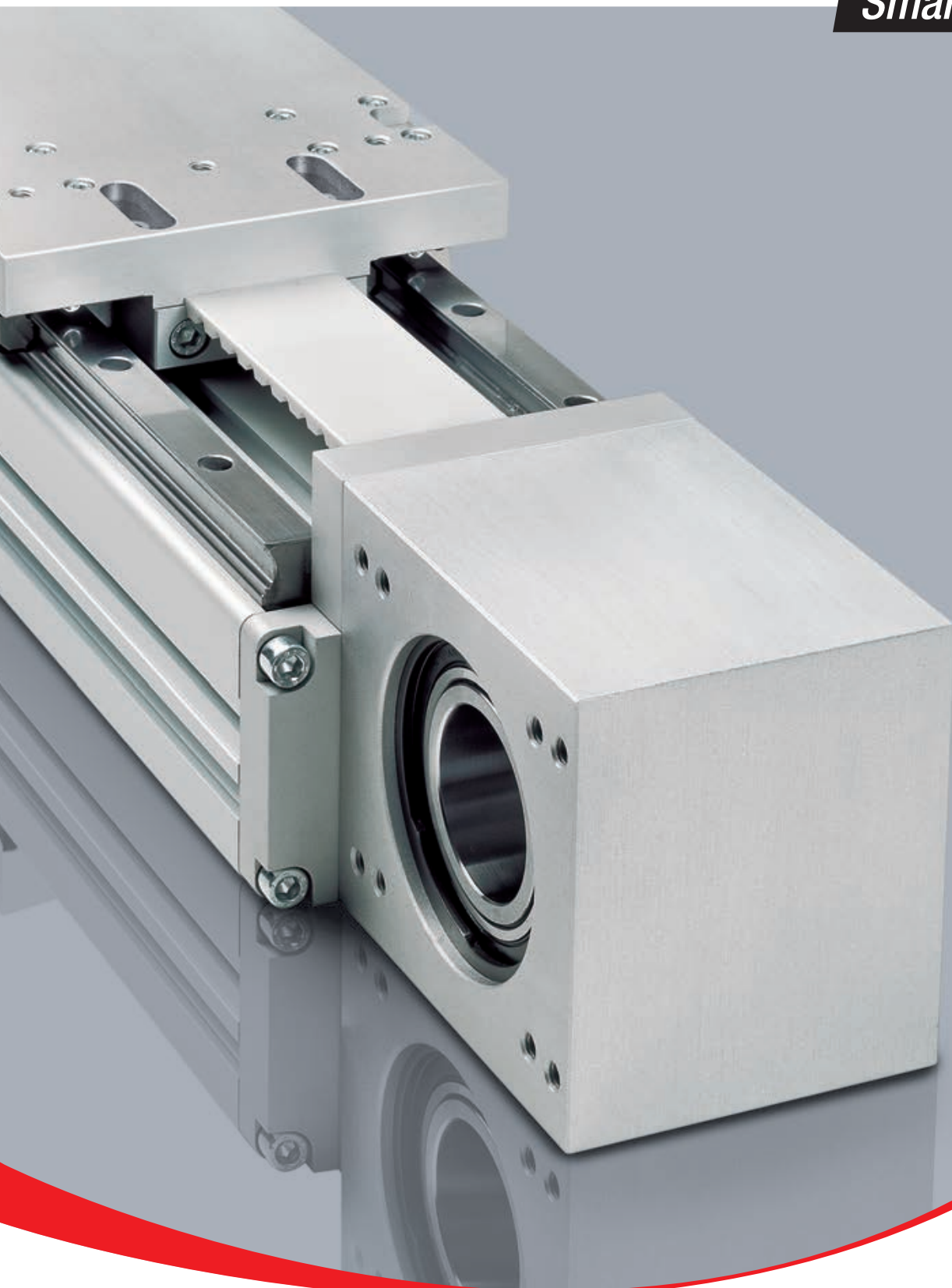

# We design and produce in order to support you

*An international group  
for technology,  
a local support for service*

*Over 40 years of know how  
in design and production*

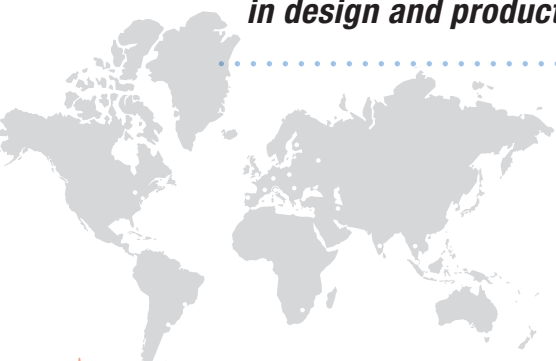

Values

Applications

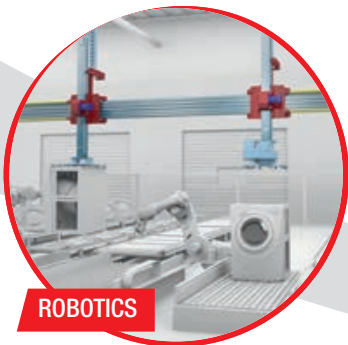

ROBOTICS

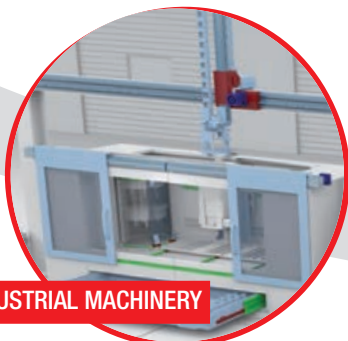

INDUSTRIAL MACHINERY



LOGISTICS

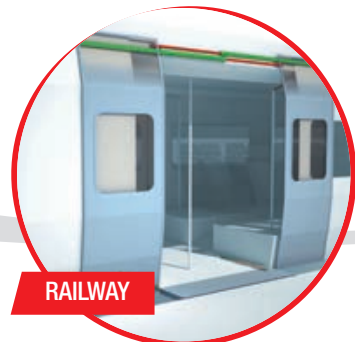

RAILWAY



## Collaboration

*High level technical consulting*

*Cross competences in several industrial sectors for an effective problem-solving*

## Solutions

*From a full range of standard products to customer specific solutions for best performance*

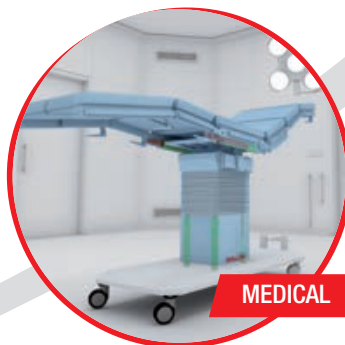

# A complete range for linear motion which reaches every customer



Linear and curved guides with ball and roller bearings, with hardened raceways, high load capacities, self-alignment and capable of working in dirty environments.

## Linear Line



## Telescopic Line

Telescopic guides with ball bearings, with hardened raceways, high load capacities and high rigidity, resistant to shocks and vibrations. For partial, total or extension up to 200% of the length of the guide.



## Actuator Line

Linear actuators with different drive and guide configurations, available with belt, screw or rack and pinion drives to cover a wide range of precision and speed requirements. Guides with bearings or recirculating ball systems for varying load capacities and environments.

*A global provider  
of solutions  
for applications  
for linear motion*



## Actuator System Line

Integrated actuators for industrial automation, wide ranging solutions that span industrial sectors: from machinery servo systems to high precision assembly systems, packaging lines and high speed production lines. Evolved from Actuator Line series in order to meet the most demanding customer needs.

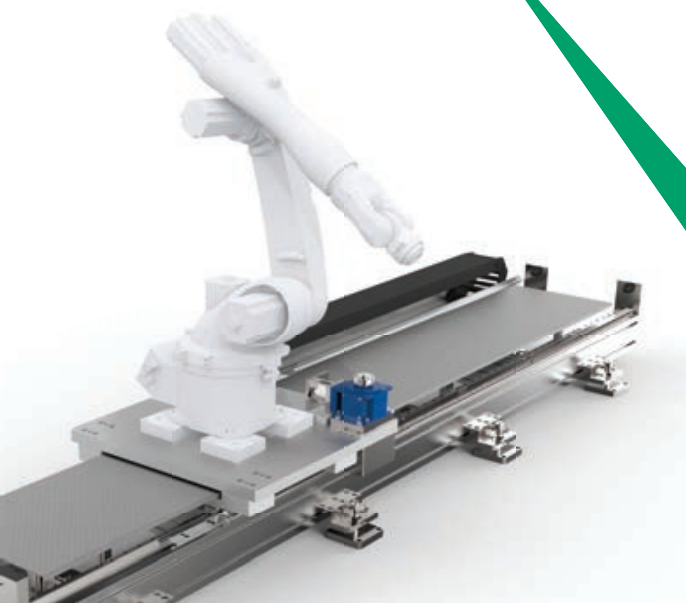

## > Smart System



### 1 E-SMART series

E-SMART series description	SS-2
The components	SS-3
The linear motion system	SS-4
E-SMART 30 SP2	SS-5
E-SMART 50 SP1 - SP2 - SP3	SS-6
E-SMART 80 SP1 - SP2	SS-7
E-SMART 80 SP3 - SP4	SS-8
E-SMART 100 SP1 - SP2	SS-9
E-SMART 100 SP3 - SP4	SS-10
Lubrication	SS-11
Simple shafts, Hollow shaft	SS-12
Linear units in parallel, Accessories	SS-13
Ordering key	SS-16

### 2 R-SMART series











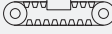



R-SMART series description	SS-17
The components	SS-18
The linear motion system	SS-19
R-SMART 120 SP4 - SP6	SS-20
R-SMART 160 SP4 - SP6	SS-21
R-SMART 220 SP4 - SP6	SS-22
Lubrication	SS-23
Simple shafts, Hollow shaft	SS-24
Accessories	SS-25
Ordering key	SS-29

### 3 S-SMART series

S-SMART series description	SS-30
The components	SS-31
The linear motion system	SS-32
S-SMART 50 SP	SS-33
S-SMART 65 SP	SS-34
S-SMART 80 SP	SS-35
Lubrication	SS-36
Simple shafts, Hollow shaft	SS-37
Accessories	SS-38
Ordering key	SS-41
Multiaxis systems	SS-42

# Pre-selection overview



Application Priority	Driving system	Section
<p>Max. speed from 4 to 15 [m/s]                      Max. acceleration from 10 to 50 [m/s<sup>2</sup>]                      Stroke up to 10 m</p>	 Belt	 Square
		 Rectangular
		 Other section
<p>High precision up to <math>\pm 0,005</math> [mm]                      Stroke up to 3.5 m</p>	 Ball screw	 Square
		 Rectangular
<p>Heavy loads up to 4.000 Kg                      Infinite stroke                      Multiple independent carriages</p>	 Rack and pinion	 Rectangular
		 Other section
<p>Vertical mounting                      Profile moving</p>	 Ω Belt	 Square
		 Rectangular
		 Rectangular
		 Other section

\* Optimal reliability in dirty environments thanks to plastic compound coated rollers

Protection	Rollon solution		
	Product Family		Product
 Protected	Plus System		ELM
	Modline		MCR/MCH with protection
 Semi-protected	Eco System		ECO
	Modline		MCR/MCH
	Uniline System		UNILINE
Open	Smart System		E-SMART
 Protected with suction	Clean Room System		ONE
 Protected	Plus System		ROBOT
Open	Smart System		R-SMART
	Modline		TCR/TCS
Open*	Speedy Rail A		SAB
 Semi-protected	Precision System		TV
			TVS
			TT
			TH
Open	Tecline		PAS
			PAR
Open*	Speedy Rail A		SAR
 Semi-protected	Smart System		S-SMART
 Semi-protected	Plus System		SC
Open	Modline		ZCR/ZCH
Open*	Speedy Rail A		ZSY



# Technical features overview



Reference		Section		Driving			Anticorrosion	Protection
Product Family	Product	Balls	Rollers	Toothed belt	Ball screw	Rack and pinion		
Plus System		ELM						 Protected
		ROBOT						 Protected
		SC						 Semi-protected
Clean Room System		ONE						 Protected with suction
Smart System		E-SMART						
		R-SMART						
		S-SMART						 Semi-protected
Eco System		ECO						 Semi-protected
Uniline System		A/C/E/ED/H						 Semi-protected
Modline		MCR MCH						 Semi-protected
		TCR TCS						
		ZCR ZCH						
		ZMCH						





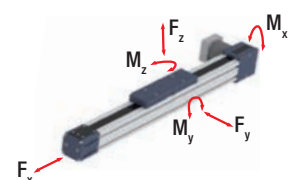







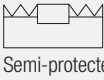



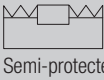



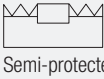



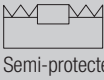





Reported data must be verified according to the application.  
\* Longer stroke is available for jointed version

Size	Max. load capacity per carriage [N]			Max. static moment per carriage [Nm]			Max. speed [m/s]	Max. acceleration [m/s <sup>2</sup> ]	Repeatability accuracy [mm]	Max stroke (per system) [mm]
	F <sub>x</sub>	F <sub>y</sub>	F <sub>z</sub>	M <sub>x</sub>	M <sub>y</sub>	M <sub>z</sub>				
50-65-80-110	4980	129400	129400	1392	11646	11646	5	50	± 0,05	6000*
100-130-160-220	9545	258800	258800	22257	28986	28986	5	50	± 0,05	6000*
65-130-160	6682	153600	153600	13555	31104	31104	5	50	± 0,05	2500
50-65-80-110	4980	104800	104800	1126	10532	10532	5	50	± 0,05	6000*
30-50-80-100	4980	130860	130860	1500	12039	12039	4	50	± 0,05	6000*
120-160-220	9960	258800	258800	21998	28468	28468	4	50	± 0,05	6000*
50-65-80	2523	51260	51260	520	3742	3742	4	50	± 0,05	2000
60-80-100	4565	76800	76800	722	7603	7603	5	50	± 0,05	6000*
40-55-75	19360	11000	17400	800,4	24917	18788	7	15	± 0,05	5700*
65-80-105	3984	51260	51260	520	5536	5536	5	50	± 0,1	10100*
140-170 200-220-230 280-360	9960	266400	266400	42624	61272	61272	5	50	± 0,1	11480
60-90-100 170-220	7470	174480	174480	12388	35681	35681	4	25	± 0,1	2500
105	4980	61120	61120	3591	10390	10390	3	25	± 0,1	2100

P  
L  
SC  
R  
SS  
SE  
SU  
SM  
L

# Technical features overview



Reference		Section		Driving			Anticorrosion	Protection
Product Family	Product	Balls	Rollers	Toothed belt	Ball screw	Rack and pinion		
Precision System		TH						 Semi-protected
		TT						 Semi-protected
		TV						 Semi-protected
		TVS						 Semi-protected
Tecline		PAR PAS						
Speedy Rail A		SAB						
		ZSY						
		SAR						

Reported data must be verified according to the application.

\* Longer stroke is available for jointed version

Size	Max. load capacity per carriage [N]			Max. static moment per carriage [Nm]			Max. speed [m/s]	Max. acceleration [m/s <sup>2</sup> ]	Repeatability accuracy [mm]	Max stroke (per system) [mm]
	F <sub>x</sub>	F <sub>y</sub>	F <sub>z</sub>	M <sub>x</sub>	M <sub>y</sub>	M <sub>z</sub>				
70-90-110-145	32600	153600	153600	6682	5053	5053	2		± 0,005	1500
100-155-225-310	30500	230500	274500	30195	26625	22365	2,5		± 0,005	3000
60-80-110	11538	85000	85000	1080	2316	2316	2,5		± 0,01	3000
170-220	66300	258800	258800	19410	47360	47360	1	5	± 0,02	3500
118-140-170-200-220-230-280-360	10989	386400	386400	65688	150310	150310	4	10	± 0,05	10800*
60-120-180-250	4565	3620	3620	372	362	362	15	10	± 0,2	7150
180	4980	2300	2600	188	806	713	8	8	± 0,2	6640
120-180-250	3598	3620	3620	372	453	453	3	10	± 0,15	7150*

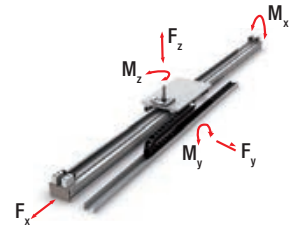
P  
ST  
LS  
R  
A

## E-SMART series



### > E-SMART series description

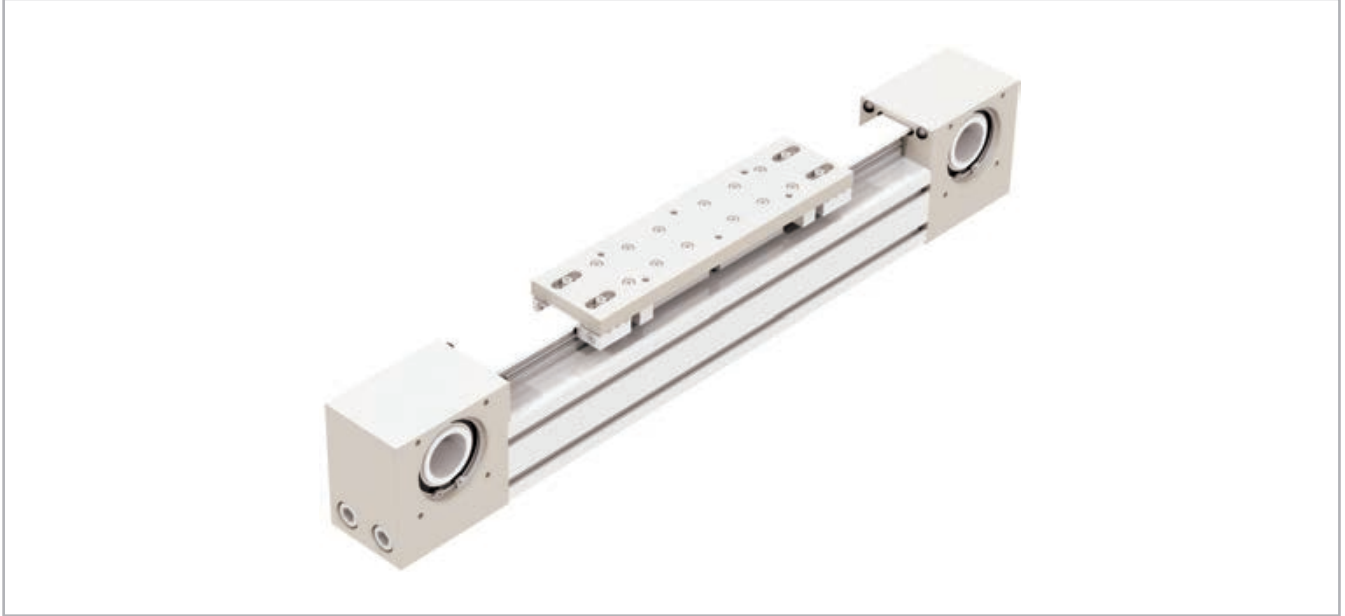

Fig. 1

#### **E-SMART**

The E-SMART series linear units have an extruded and anodized aluminum self-supporting structure with a profile available in four sizes from 30 to 100mm. Transmission is achieved with a polyurethane steel reinforced driving belt. Also featured is a single rail with one or more recirculating ball bearing runner blocks.

## > The components

### Extruded bodies

The anodized aluminum extrusions used for the bodies of the Rollon SMART series linear units were designed and manufactured in cooperation with a leading company in this field to obtain the right combination of high mechanical strength and reduced weight. The anodized aluminum alloy 6060 used (see physical chemical characteristics below for further information) was extruded with dimensional tolerances complying with EN 755-9 standards.

### Driving belt

The Rollon SMART series linear units use steel reinforced polyurethane drive belts with AT pitch. This type of belt is ideal due to its high load trans-

mission characteristics, compact size, and low noise. Used in conjunction with a backlash-free pulley, smooth alternating motion can be achieved. Optimization of the maximum belt width/body dimension ratio enables the following performance characteristics to be achieved:

- High speed
- Low noise
- Low wear

### Carriage

The carriage of the Rollon SMART series linear units is made entirely of machined anodized aluminum. The dimensions vary depending on the type. Rollon offers multiple carriages to accommodate a vast array of applications.

### General data about aluminum used: AL 6060

Chemical composition [%]

Al	Mg	Si	Fe	Mn	Zn	Cu	Impurites
Remainder	0.35-0.60	0.30-0.60	0.30	0.10	0.10	0.10	0.05-0.15

Tab. 1

Physical characteristics

Density	Coeff. of elasticity	Coeff. of thermal expansion (20°-100°C)	Thermal conductivity (20°C)	Specific heat (0°-100°C)	Resistivity	Melting point
$\frac{\text{kg}}{\text{dm}^3}$	$\frac{\text{kN}}{\text{mm}^2}$	$\frac{10^{-6}}{\text{K}}$	$\frac{\text{W}}{\text{m} \cdot \text{K}}$	$\frac{\text{J}}{\text{kg} \cdot \text{K}}$	$\Omega \cdot \text{m} \cdot 10^{-9}$	°C
2.7	70	23.8	200	880-900	33	600-655

Tab. 2

Mechanical characteristics

Rm	Rp (02)	A	HB
$\frac{\text{N}}{\text{mm}^2}$	$\frac{\text{N}}{\text{mm}^2}$	%	—
250	200	10	75

Tab. 3

## > The linear motion system

The linear motion system has been designed to meet the load capacity, speed, and maximum acceleration conditions of a wide variety of applications.

### Performance characteristics:

- The ball bearing guides with high load capacity are mounted in a dedicated seat on the aluminum body.
- The carriage of the linear unit is assembled on preloaded ball bearing blocks that enables the carriage to withstand loading in the four main directions.
- The ball bearing carriages of the SP versions are also fitted with a retention cage that eliminates "steel-steel" contact between adjacent revolving parts and prevents misalignment.
- The blocks have seals on both sides and, when necessary, an additional scraper can be fitted for very dusty conditions.

### The linear motion system described above offers:

- High speed and acceleration
- High load capacity
- High permissible bending moments
- Low friction
- Long life
- Low noise

### E-SMART section

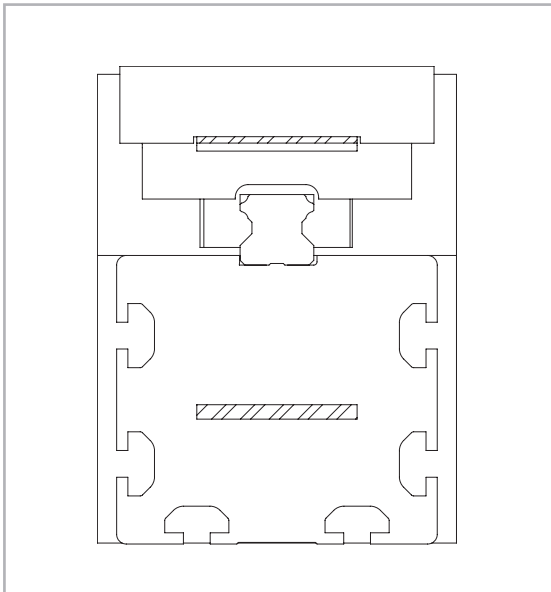
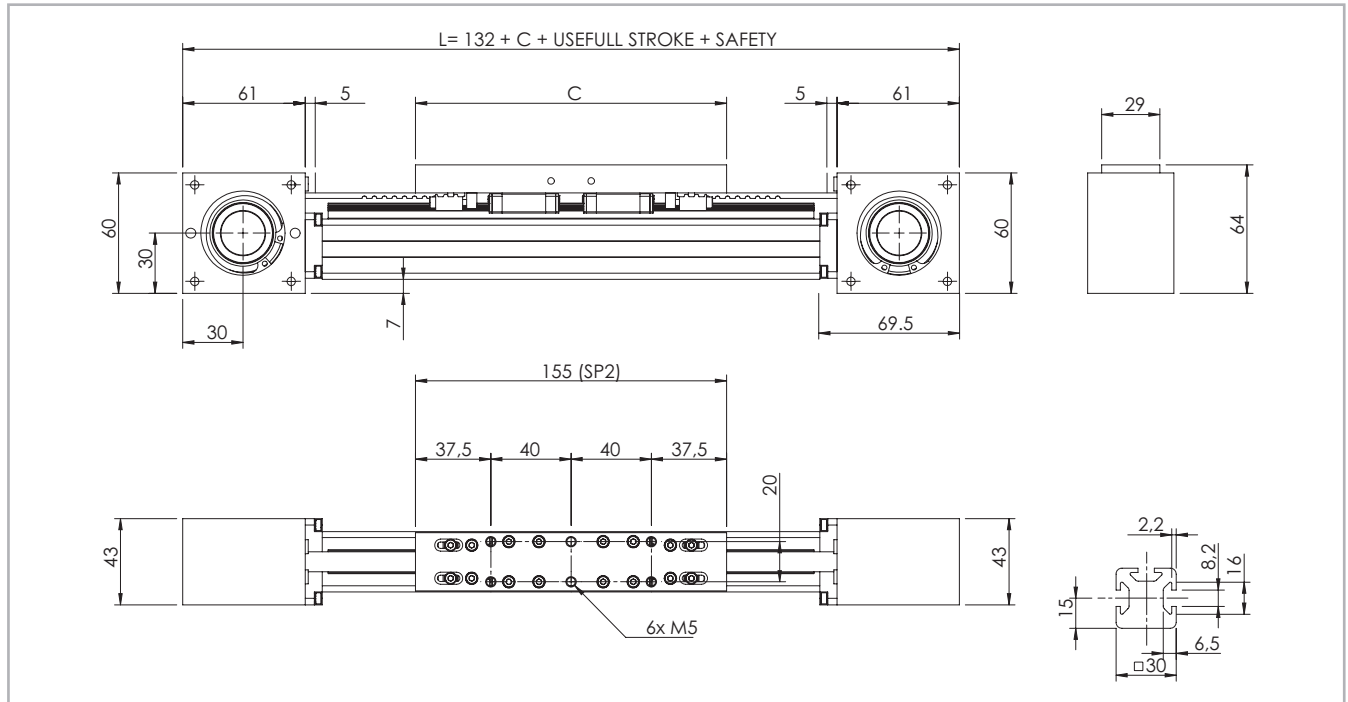

Fig. 2

> E-SMART 30 SP2

E-SMART 30 Dimensions



The length of the safety stroke is provided on request according to the customer's specific requirements.

Fig. 3

Technical data

	Type
	E-SMART 30 SP2
Max. useful stroke length [mm]	3700
Max. positioning repeatability [mm]*1	± 0.05
Max. speed [m/s]	4.0
Max. acceleration [m/s <sup>2</sup> ]	50
Type of belt	10 AT 5
Type of pulley	Z 24
Pulley pitch diameter [mm]	38.2
Carriage displacement per pulley turn [mm]	120
Carriage weight [kg]	0.28
Zero travel weight [kg]	1.83
Weight for 100 mm useful stroke [kg]	0.16
Starting torque [Nm]	0.15
Moment of inertia of pulleys [g · mm <sup>2</sup> ]	57.630
Rail size [mm]	12 mini

\*1) Positioning repeatability is dependent on the type of transmission used.

Tab. 4

E-SMART 30 - Load capacity

Type	F <sub>x</sub> [N]		F <sub>y</sub> [N]		F <sub>z</sub> [N]	M <sub>x</sub> [Nm]	M <sub>y</sub> [Nm]	M <sub>z</sub> [Nm]
	Stat.	Dyn.	Stat.	Dyn.	Stat.	Stat.	Stat.	Stat.
E-SMART 30 SP2	385	242	7060	6350	7060	46.2	166	166

See verification under static load and lifetime on page SL-2 and SL-3

Tab. 7

Moments of inertia of the aluminum body

Type	I <sub>x</sub> [10 <sup>7</sup> mm <sup>4</sup> ]	I <sub>y</sub> [10 <sup>7</sup> mm <sup>4</sup> ]	I <sub>p</sub> [10 <sup>7</sup> mm <sup>4</sup> ]
E-SMART 30 SP2	0.003	0.003	0.007

Tab. 5

Driving belt

The driving belt is manufactured from a friction resistant polyurethane and with steel cords for high tensile stress resistance.

Type	Type of belt	Belt width [mm]	Weight [kg/m]
E-SMART 30 SP2	10 AT 5	10	0.033

Tab. 6

Belt length (mm) = 2 x L - 100 (SP2)

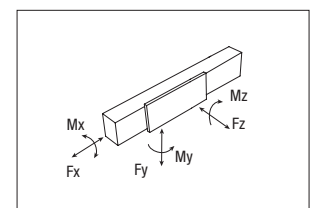



> E-SMART 50 SP1 - SP2 - SP3

E-SMART 50 Dimensions

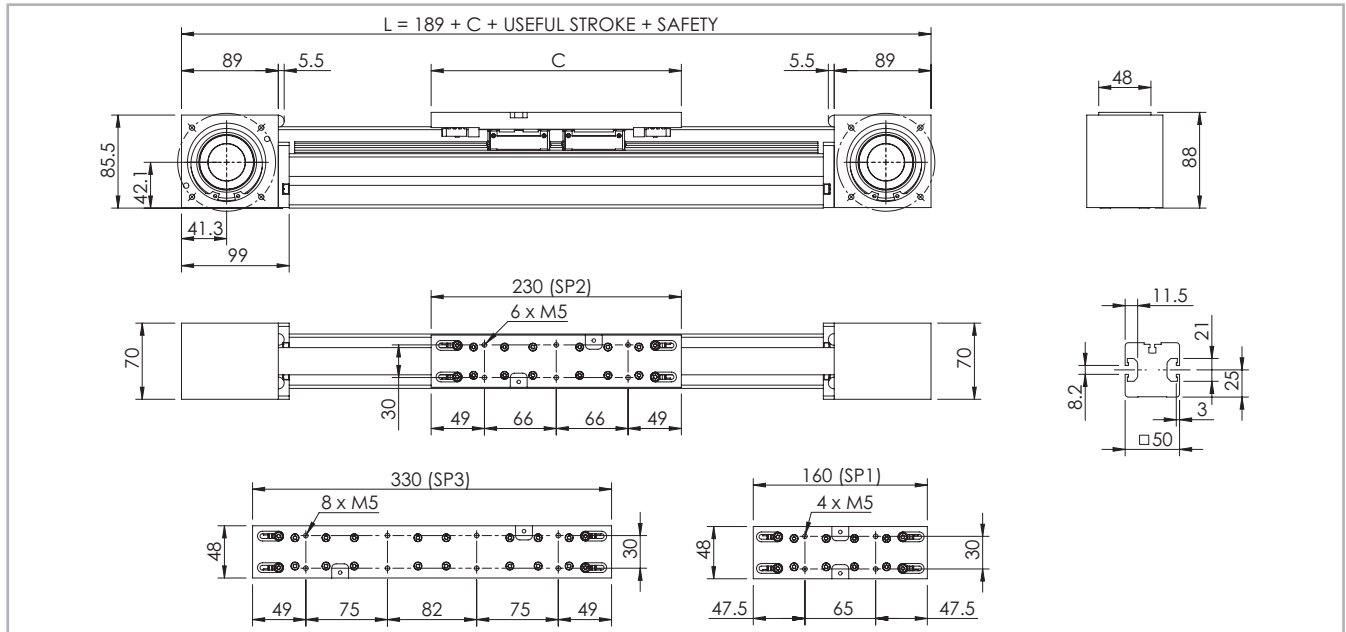

The length of the safety stroke is provided on request according to the customer's specific requirements.

Fig. 4

Technical data

	Type		
	E-SMART 50 SP1	E-SMART 50 SP2	E-SMART 50 SP3
Max. useful stroke length [mm]*1	6145	6075	5975
Max. positioning repeatability [mm]*2	± 0.05	± 0.05	± 0.05
Max. speed [m/s]	4.0	4.0	4.0
Max. acceleration [m/s <sup>2</sup> ]	50	50	50
Type of belt	25 AT 5	25 AT 5	25 AT 5
Type of pulley	Z 40	Z 40	Z 40
Pulley pitch diameter [mm]	63.66	63.66	63.66
Carriage displacement per pulley turn [mm]	200	200	200
Carriage weight [kg]	0.54	0.85	1.21
Zero travel weight [kg]	4.89	5.4	6.16
Weight for 100 mm useful stroke [kg]	0.34	0.34	0.34
Starting torque [Nm]	0.35	0.35	0.55
Moment of inertia of pulleys [g · mm <sup>2</sup> ]	891.270	891.270	891.270
Rail size [mm]	15	15	15

\*1) It is possible to obtain stroke up to 11.270 (SP1), 11.200 (SP2), 11.100 (SP3) by means of special Rollon joints. Tab. 8

\*2) Positioning repeatability is dependent on the type of transmission used.

E-SMART 50 - Load capacity

Type	F <sub>x</sub> [N]		F <sub>y</sub> [N]		F <sub>z</sub> [N]	M <sub>x</sub> [Nm]	M <sub>y</sub> [Nm]	M <sub>z</sub> [Nm]
	Stat.	Dyn.	Stat.	Dyn.	Stat.	Stat.	Stat.	Stat.
E-SMART 50 SP1	1050	750	15280	9945	15280	120	90	90
E-SMART 50 SP2	1050	750	30560	19890	30560	240	1054	1054
E-SMART 50 SP3	1050	750	45840	29835	45840	360	2582	2582

See verification under static load and lifetime on page SL-2 and SL-3

Moments of inertia of the aluminum body

Type	I <sub>x</sub> [10 <sup>7</sup> mm <sup>4</sup> ]	I <sub>y</sub> [10 <sup>7</sup> mm <sup>4</sup> ]	I <sub>p</sub> [10 <sup>7</sup> mm <sup>4</sup> ]
E-SMART 50 SP	0.021	0.020	0.041

Tab. 9

Driving belt

The driving belt is manufactured from a friction resistant polyurethane and with steel cords for high tensile stress resistance.

Type	Type of belt	Belt width [mm]	Weight [kg/m]
E-SMART 50 SP	25 AT 5	25	0.080

Tab. 10

Belt length (mm) = 2 x L - 60 (SP1)  
 2 x L - 125 (SP2)  
 2 x L - 225 (SP3)

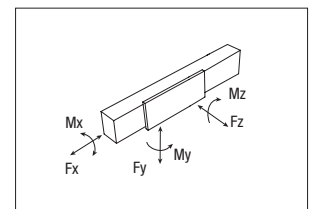

Tab. 11

> E-SMART 80 SP1 - SP2

E-SMART 80 Dimensions

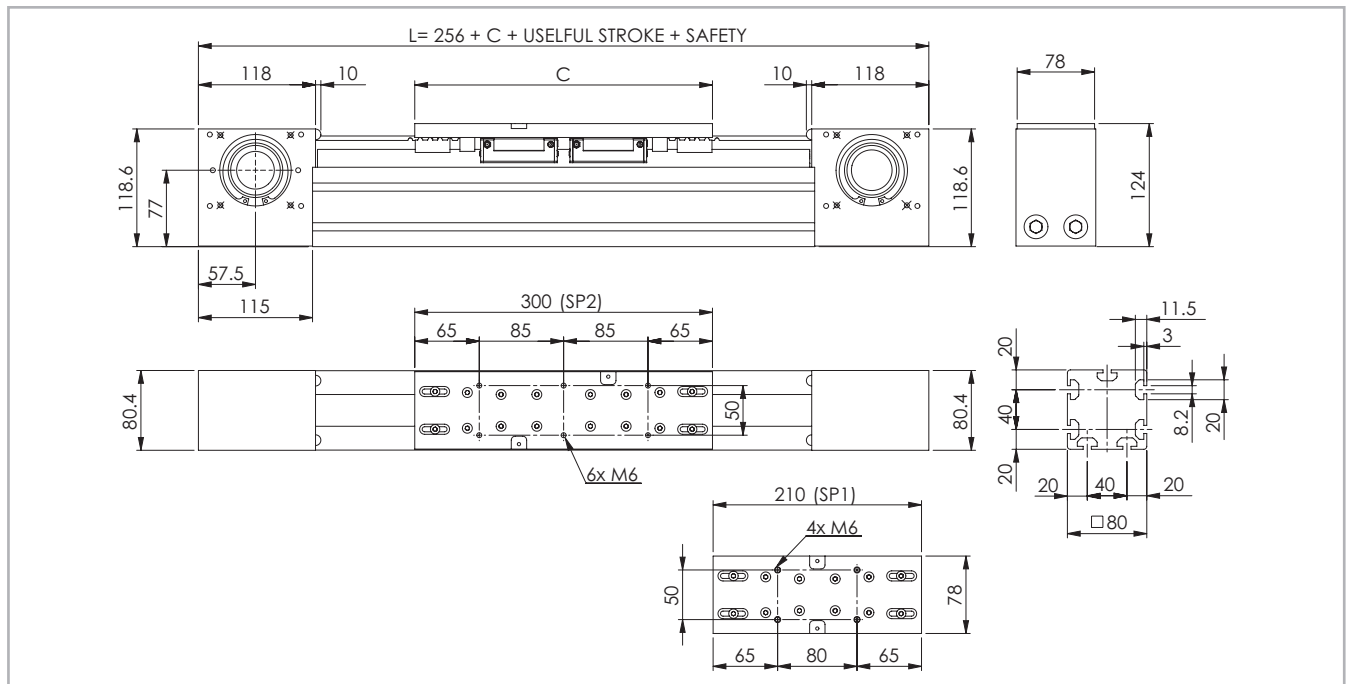

The length of the safety stroke is provided on request according to the customer's specific requirements.

Fig. 5

Technical data

	Type	
	E-SMART 80 SP1	E-SMART 80 SP2
Max. useful stroke length [mm]*1	6060	5970
Max. positioning repeatability [mm]*2	± 0.05	± 0.05
Max. speed [m/s]	4.0	4.0
Max. acceleration [m/s <sup>2</sup> ]	50	50
Type of belt	32 AT 10	32 AT 10
Type of pulley	Z 21	Z 21
Pulley pitch diameter [mm]	66,84	66,84
Carriage displacement per pulley turn [mm]	210	210
Carriage weight [kg]	1.34	1.97
Zero travel weight [kg]	9.94	11.31
Weight for 100 mm useful stroke [kg]	0.76	0.76
Starting torque [Nm]	0.95	1.3
Moment of inertia of pulleys [g · mm <sup>2</sup> ]	938.860	938.860
Rail size [mm]	20	20

\*1) It is possible to obtain stroke up to 11.190 (SP1), 11.100 (SP2) by means of special Rollon joints.  
 \*2) Positioning repeatability is dependent on the type of transmission used.

Tab. 12

E-SMART 80 - Load capacity

Type	F <sub>x</sub> [N]		F <sub>y</sub> [N]		F <sub>z</sub> [N]	M <sub>x</sub> [Nm]	M <sub>y</sub> [Nm]	M <sub>z</sub> [Nm]
	Stat.	Dyn.	Stat.	Dyn.	Stat.	Stat.	Stat.	Stat.
E-SMART 80 SP1	2523	1672	25630	18318	25630	260	190	190
E-SMART 80 SP2	2523	1672	51260	36637	51260	520	1874	1874

See verification under static load and lifetime on page SL-2 and SL-3

Tab. 15  
SS-7

Moments of inertia of the aluminum body

Type	I <sub>x</sub> [10 <sup>7</sup> mm <sup>4</sup> ]	I <sub>y</sub> [10 <sup>7</sup> mm <sup>4</sup> ]	I <sub>p</sub> [10 <sup>7</sup> mm <sup>4</sup> ]
E-SMART 80 SP	0.143	0.137	0.280

Tab. 13

Driving belt

The driving belt is manufactured from a friction resistant polyurethane and with steel cords for high tensile stress resistance.

Type	Type of belt	Belt width [mm]	Weight [kg/m]
E-SMART 80 SP	32 AT 10	32	0.186

Tab. 14

Belt length (mm) = 2 x L - 135 (SP1)  
 2 x L - 225 (SP2)

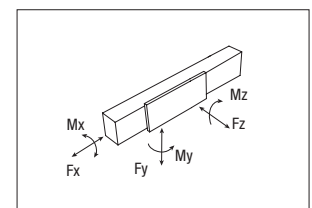

> E-SMART 80 SP3 - SP4

E-SMART 80 Dimensions

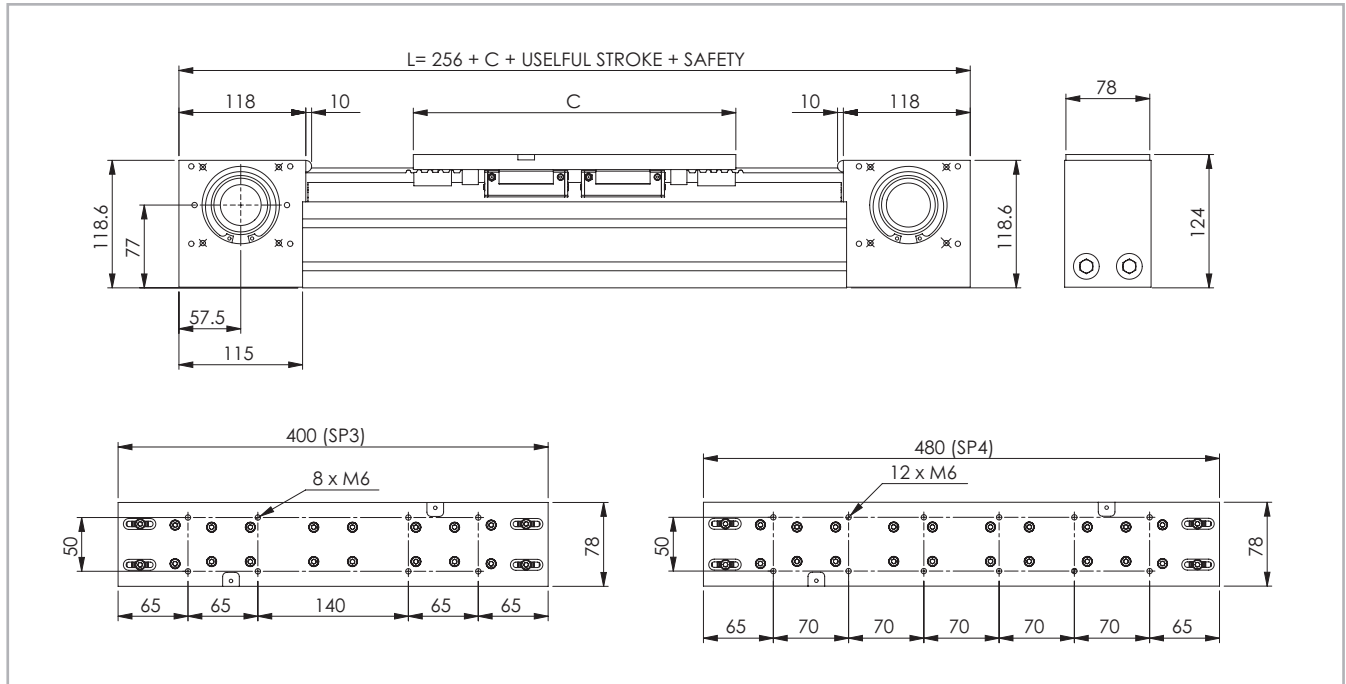

The length of the safety stroke is provided on request according to the customer's specific requirements.

Fig. 6

Technical data

	Type	
	E-SMART 80 SP3	E-SMART 80 SP4
Max. useful stroke length [mm]*1	5870	5790
Max. positioning repeatability [mm]*2	± 0.05	± 0.05
Max. speed [m/s]	4.0	4.0
Max. acceleration [m/s <sup>2</sup> ]	50	50
Type of belt	32 AT 10	32 AT 10
Type of pulley	Z 21	Z 21
Pulley pitch diameter [mm]	66,84	66,84
Carriage displacement per pulley turn [mm]	210	210
Carriage weight [kg]	2.63	3.23
Zero travel weight [kg]	12.83	14.06
Weight for 100 mm useful stroke [kg]	0.76	0.76
Starting torque [Nm]	1.4	1.52
Moment of inertia of pulleys [g · mm <sup>2</sup> ]	938.860	938.860
Rail size [mm]	20	20

\*1) It is possible to obtain stroke up to 11.000 (SP3), 10.920 (SP4) by means of special Rollon joints.  
 \*2) Positioning repeatability is dependent on the type of transmission used.

Tab. 16

E-SMART 80 - Load capacity

Type	F <sub>x</sub> [N]		F <sub>y</sub> [N]		F <sub>z</sub> [N]	M <sub>x</sub> [Nm]	M <sub>y</sub> [Nm]	M <sub>z</sub> [Nm]
	Stat.	Dyn.	Stat.	Dyn.	Stat.	Stat.	Stat.	Stat.
E-SMART 80 SP3	2523	1672	76890	54956	76890	780	4870	4870
E-SMART 80 SP4	2523	1672	102520	73274	102520	1040	6920	6920

See verification under static load and lifetime on page SL-2 and SL-3

Tab. 19

Moments of inertia of the aluminum body

Type	I <sub>x</sub> [10 <sup>7</sup> mm <sup>4</sup> ]	I <sub>y</sub> [10 <sup>7</sup> mm <sup>4</sup> ]	I <sub>p</sub> [10 <sup>7</sup> mm <sup>4</sup> ]
E-SMART 80 SP	0.143	0.137	0.280

Tab. 17

Driving belt

The driving belt is manufactured from a friction resistant polyurethane and with steel cords for high tensile stress resistance.

Type	Type of belt	Belt width [mm]	Weight [kg/m]
E-SMART 80 SP	32 AT 10	32	0.186

Tab. 18

Belt length (mm) = 2 x L - 325 (SP3)  
 2 x L - 405 (SP4)

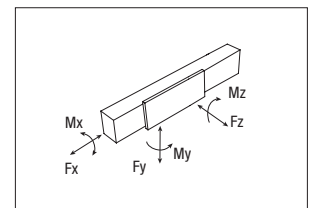

> E-SMART 100 SP1 - SP2

E-SMART 100 Dimensions

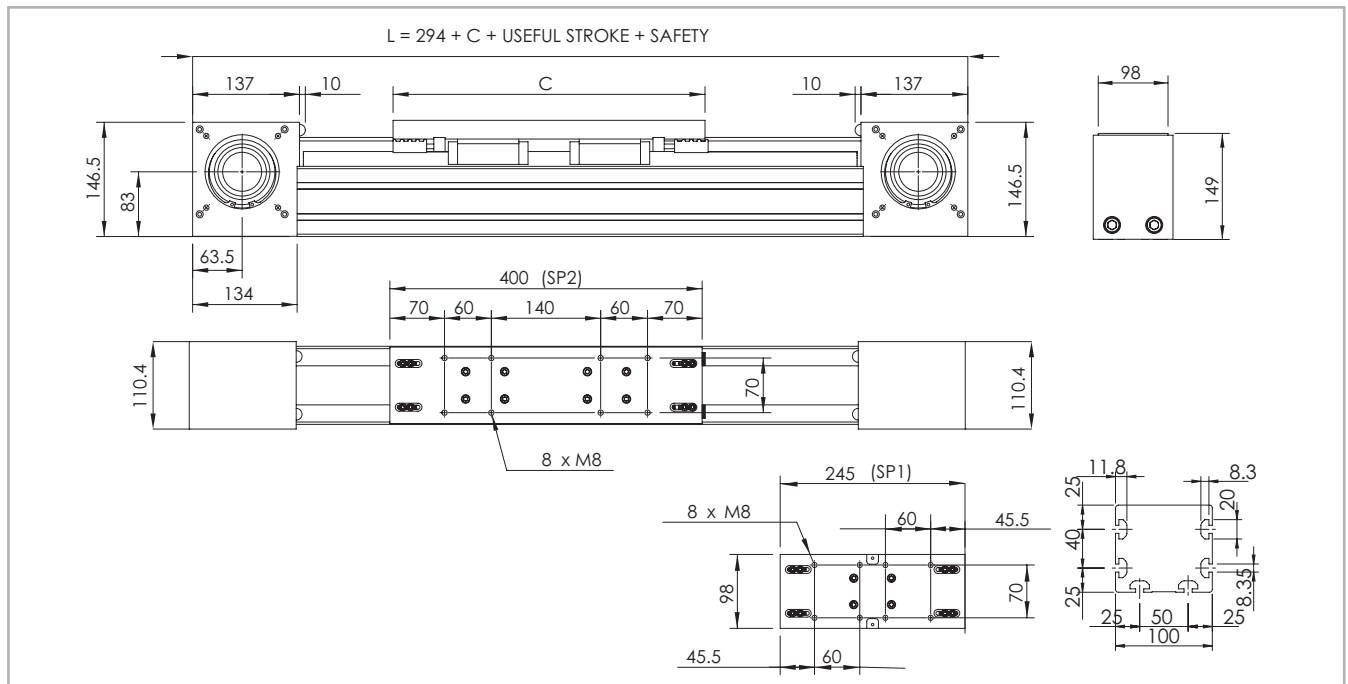

The length of the safety stroke is provided on request according to the customer's specific requirements.

Fig. 7

Technical data

	Type	
	E-SMART 100 SP1	E-SMART 100 SP2
Max. useful stroke length [mm]*1	6025	5870
Max. positioning repeatability [mm]*2	± 0.05	± 0.05
Max. speed [m/s]	4.0	4.0
Max. acceleration [m/s <sup>2</sup> ]	50	50
Type of belt	50 AT 10	50 AT 10
Type of pulley	Z 27	Z 27
Pulley pitch diameter [mm]	85.94	85.94
Carriage displacement per pulley turn [mm]	270	270
Carriage weight [kg]	2.72	4.42
Zero travel weight [kg]	18.86	22.38
Weight for 100 mm useful stroke [kg]	1.3	1.3
Starting torque [Nm]	2.1	2.4
Moment of inertia of pulleys [g · mm <sup>2</sup> ]	4.035.390	4.035.390
Rail size [mm]	25	25

\*1) It is possible to obtain stroke up to 11.155 (SP1), 11.000 (SP2) by means of special Rollon joints.  
 \*2) Positioning repeatability is dependent on the type of transmission used.

Tab. 20

E-SMART 100 Load capacity

Type	F <sub>x</sub> [N]		F <sub>y</sub> [N]		F <sub>z</sub> [N]	M <sub>x</sub> [Nm]	M <sub>y</sub> [Nm]	M <sub>z</sub> [Nm]
	Stat.	Dyn.	Stat.	Dyn.	Stat.	Stat.	Stat.	Stat.
E-SMART 100 SP1	4980	3390	43620	31192	43620	500	450	450
E-SMART 100 SP2	4980	3390	87240	62385	87240	1000	6805	6805

See verification under static load and lifetime on page SL-2 and SL-3

Tab. 23  
SS-9

Moments of inertia of the aluminum body

Type	I <sub>x</sub> [10 <sup>7</sup> mm <sup>4</sup> ]	I <sub>y</sub> [10 <sup>7</sup> mm <sup>4</sup> ]	I <sub>p</sub> [10 <sup>7</sup> mm <sup>4</sup> ]
E-SMART 100 SP	0.247	0.316	0.536

Tab. 21

Driving belt

The driving belt is manufactured from a friction resistant polyurethane and with steel cords for high tensile stress resistance.

Type	Type of belt	Belt width [mm]	Weight [kg/m]
E-SMART 100 SP	50 AT 10	50	0.290

Tab. 22

Belt length (mm) = 2 x L - 120 (SP1)  
 2 x L - 275 (SP2)

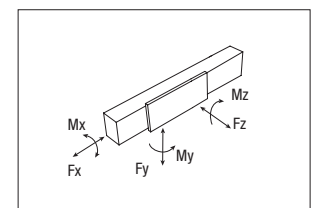

> E-SMART 100 SP3 - SP4

E-SMART 100 Dimensions

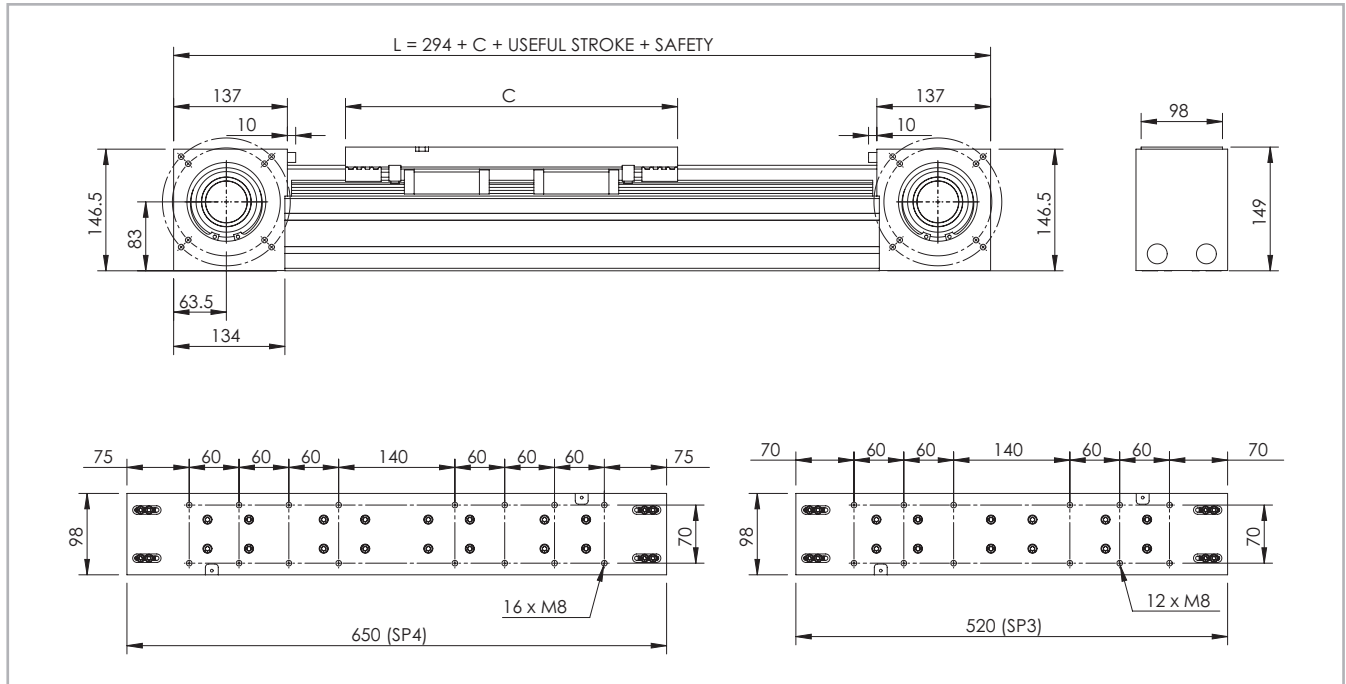

The length of the safety stroke is provided on request according to the customer's specific requirements.

Fig. 8

Technical data

	Type	
	E-SMART 100 SP3	E-SMART 100 SP4
Max. useful stroke length [mm]*1	5750	5620
Max. positioning repeatability [mm]*2	± 0.05	± 0.05
Max. speed [m/s]	4.0	4.0
Max. acceleration [m/s <sup>2</sup> ]	50	50
Type of belt	50 AT 10	50 AT 10
Type of pulley	Z 27	Z 27
Pulley pitch diameter [mm]	85.94	85.94
Carriage displacement per pulley turn [mm]	270	270
Carriage weight [kg]	5.85	7.34
Zero travel weight [kg]	25.22	28.25
Weight for 100 mm useful stroke [kg]	1.3	1.3
Starting torque [Nm]	2.6	2.8
Moment of inertia of pulleys [g · mm <sup>2</sup> ]	4.035.390	4.035.390
Rail size [mm]	25	25

Tab. 24

\*1) It is possible to obtain stroke up to 10.880 (SP3), 10.750 (SP4) by means of special Rollon joints.  
 \*2) Positioning repeatability is dependent on the type of transmission used.

E-SMART 100 Load capacity

Type	F <sub>x</sub> [N]		F <sub>y</sub> [N]		F <sub>z</sub> [N]	M <sub>x</sub> [Nm]	M <sub>y</sub> [Nm]	M <sub>z</sub> [Nm]
	Stat.	Dyn.	Stat.	Dyn.	Stat.	Stat.	Stat.	Stat.
E-SMART 100 SP3	4980	3390	130860	93577	130860	1500	12039	12039
E-SMART 100 SP4	4980	3390	174480	124770	174480	2000	17710	17710

See verification under static load and lifetime on page SL-2 and SL-3

Tab. 27

Moments of inertia of the aluminum body

Type	I <sub>x</sub> [10 <sup>7</sup> mm <sup>4</sup> ]	I <sub>y</sub> [10 <sup>7</sup> mm <sup>4</sup> ]	I <sub>p</sub> [10 <sup>7</sup> mm <sup>4</sup> ]
E-SMART 100 SP	0.247	0.316	0.536

Tab. 25

Driving belt

The driving belt is manufactured from a friction resistant polyurethane and with steel cords for high tensile stress resistance.

Type	Type of belt	Belt width [mm]	Weight [kg/m]
E-SMART 100 SP	50 AT 10	50	0.290

Tab. 26

Belt length (mm) = 2 x L - 395 (SP3)  
 2 x L - 252 (SP4)

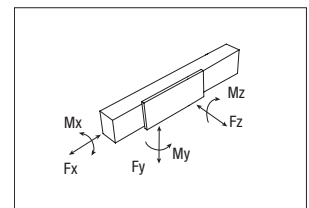

## > Lubrication

### SP linear units with ball bearing guides

The ball bearing carriages of the SP versions are fitted with a retention cage that eliminates "steel-steel" contact between adjacent revolving parts and prevents misalignment of these in the circuits.

This system guarantees a long interval between maintenances: SP version: every 2000 km or 1 year of use, based on the value reached first. If

a longer service life is required or in case of high dynamic or high loaded applications please contact our offices for further verification.

### E-SMART

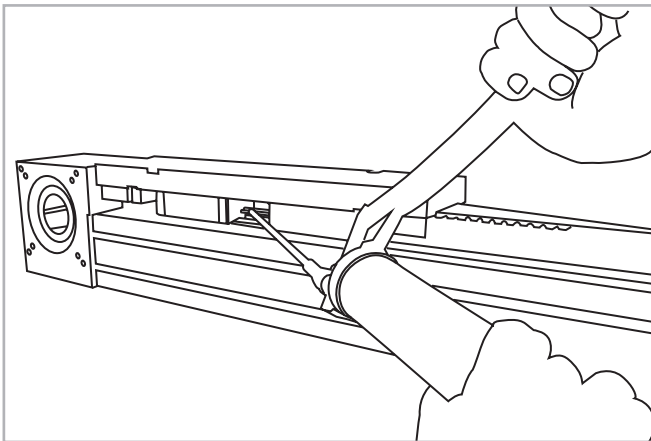

Fig. 9

- Insert the tip of the grease gun into the specific grease blocks.
- Type of lubricant: Lithium soap grease of class NLGI 2.
- For specially stressed applications or hostile environmental conditions, lubrication should be applied out more frequently.  
Contact Rollon for further advice

Quantity of lubricant necessary for re-lubrication of each block:

Type	Unit [cm <sup>3</sup> ]
E-SMART 30	0.5
E-SMART 50	0.2
E-SMART 80	0.5
E-SMART 100	0.6

Tab. 28

## > Simple shafts

### AS type simple shafts

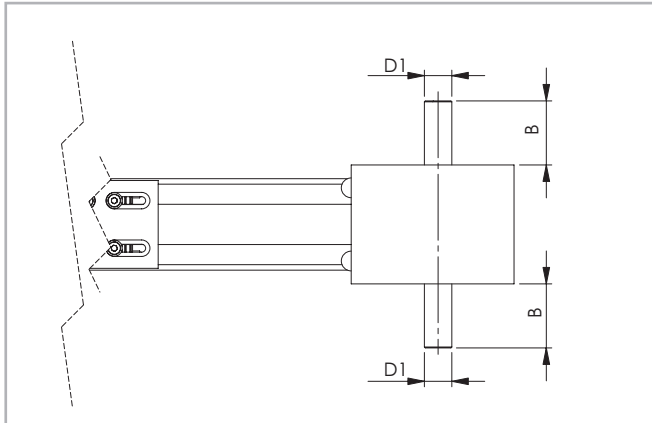

Position of the simple shaft can be to the right or to the left of the drive head.

Fig. 10

This head configuration is obtained by utilizing an assembly kit delivered as a separate accessory item.

Shaft can be installed on the left or right side of the drive head as decided by the customer.

### Units (mm)

Applicable to unit	Shaft type	B	D1	AS assembly kit code
E-SMART 30	AS 12	25	12h7	G000348
E-SMART 50	AS 15	35	15h7	G000851
E-SMART 80	AS 20	36.5	20h7	G000828
E-SMART 100	AS 25	50	25h7	G000649

Tab. 29

## > Hollow shaft

### Hollow shaft type FP - Standard supply

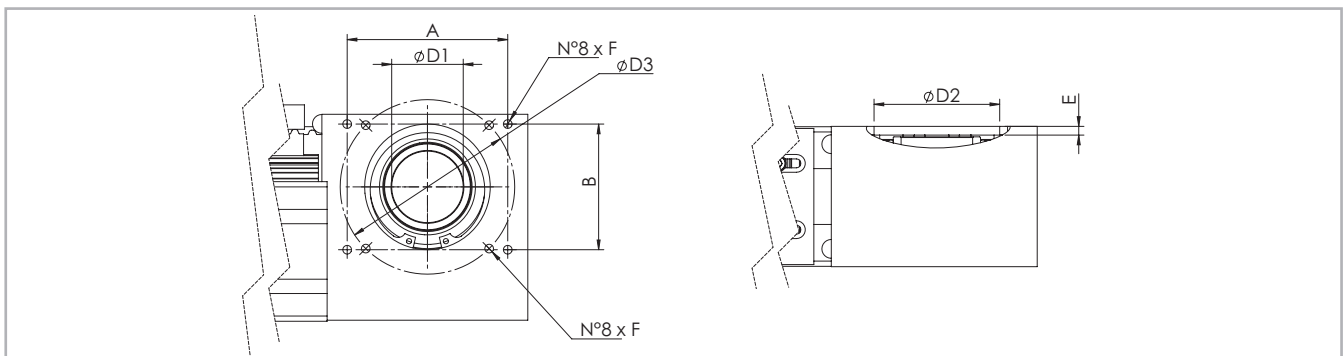

Fig. 11

### Units (mm)

Applicable to unit	Shaft type	D1	D2	D3	E	F	A x B	Drive head code
E-SMART 30	FP 22	22H7	42	68	3	M5	-	2T
E-SMART 50	FP 34	34H7	72	90	2.5	M6	-	2T
E-SMART 80	FP 41	41H7	72	100	5	M6	92x72	2Z
E-SMART 100	FP 50	50H7	95	130	3.5	M8	109x109	2Y

Tab. 30

An (optional) connection flange is required to fit the standard reduction units selected by Rollon.

For further information contact our offices.

## > Linear units in parallel

### Synchronization kit for use of SMART linear units in parallel

When movement consisting of two linear units in parallel is essential, a synchronization kit must be used. This consists of original Rollon lamina type precision joints complete with tapered splines and hollow aluminum drive shafts.

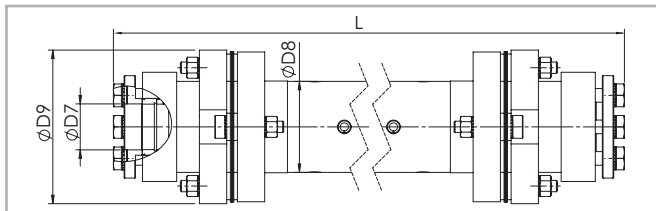

Fig. 12

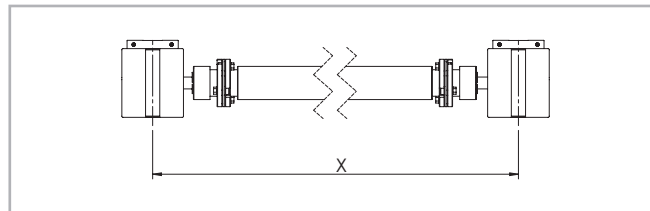

Fig. 13

### Dimensions (mm)

Applicable to unit	Shaft type	D7	D8	D9	Code	Formula for length calculation
E-SMART 30	AP 12	12	25	45	GK12P...1A	$L = X - 51$ [mm]
E-SMART 50	AP 15	15	40	69.5	GK15P...1A	$L = X - 79$ [mm]
E-SMART 80	AP 20	20	40	69.5	GK20P...1A	$L = X - 97$ [mm]
E-SMART 100	AP 25	25	70	99	GK25P...1A	$L = X - 145$ [mm]

Tab. 31

## > Accessories

### Fixing by brackets

The ball bearing guide linear drive system of Rollon SMART System series linear units enables them to support loads in any direction.

They can therefore be installed in any position.

To install the SMART System series units, we recommend use of one of the systems indicated below:

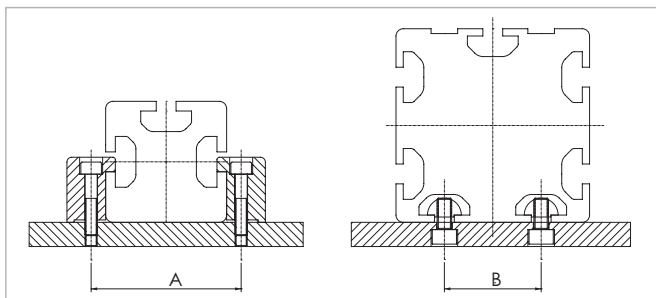

Fig. 14

### Moment of inertia [g mm<sup>2</sup>] C1 + C2 · (X-Y)

	C1	C2	Y	Weight [ Kg ] C1+C2 · (X-Y)	
	[g mm <sup>2</sup> ]	[g mm <sup>2</sup> ]	[mm]	C1 [Kg]	C2 [Kg mm]
GK12P	61.456	69	166	0.308	0.00056
GK15P	906.928	464	210	2.28	0.00148
GK20P	1.014.968	464	250	2.48	0.00148
GK25P	5.525.250	4.708	356	6.24	0.0051

32

### Dimensions (mm)

	A	B
E-SMART 30	42	-
E-SMART 50	62	-
E-SMART 80	92	40
E-SMART 100	120	50

Tab. 33



Fixing brackets

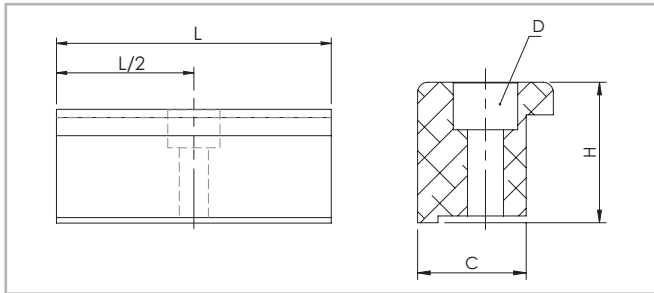
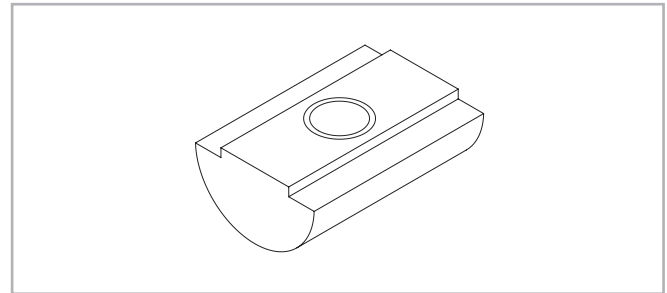

Fig. 15

T-nuts



Steel nuts to be used in the slots of the body.

Fig. 16

Dimensions (mm)

	C	H	L	D	Cod. Rollon
E-SMART 30	16	17.5	50	M5	1001490
E-SMART 50	16	26.9	50	M5	1000097
E-SMART 80	16	20.7	50	M5	1000111
E-SMART 100	31	28.5	100	M10	1002377

Tab. 34

Units (mm)

	Hole	Length	Cod. Rollon
E-SMART 30	M5	20	6000436
E-SMART 50	M6	20	6000437
E-SMART 80	M6	20	6000437
E-SMART 100	M6	20	6000437

Tab. 35

Proximity

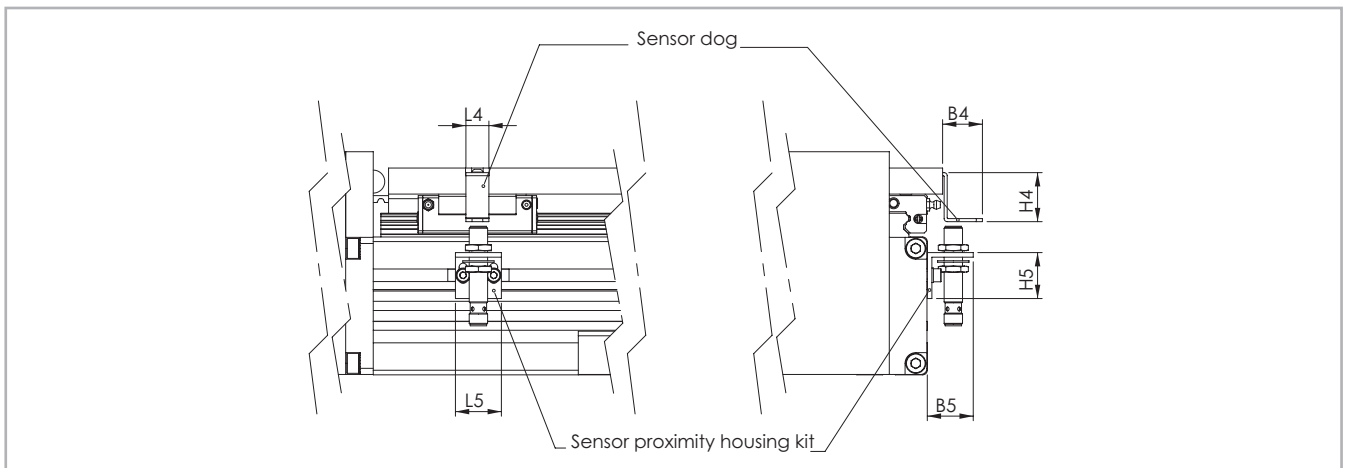

Fig. 17

Sensor proximity housing kit

Aluminum block equipped with T-nuts for fixing

Sensor dog

Iron plate mounted on the carriage used for the proximity operation

Units (mm)

	B4	B5	L4	L5	H4	H5	For proximity	Sensor dog code	Sensor proximity kit code
E-SMART 30	30	30	30	30	15	30	∅ 8	G000847	G000901
E-SMART 50	26	30	15	30	32	30	∅ 8	G000833	G000838
E-SMART 80	26	30	15	30	32	30	∅ 8	G000833	G000838
E-SMART 100	26	30	15	30	32	30	∅ 8	G000833	G000838

Tab. 36

Adapter flange for gearbox assembly

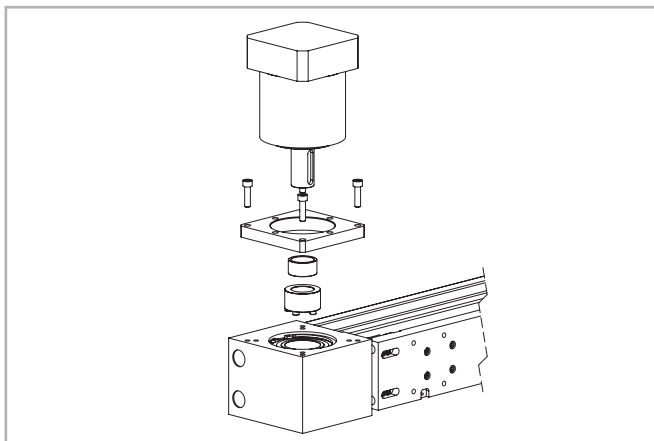

Fig. 18

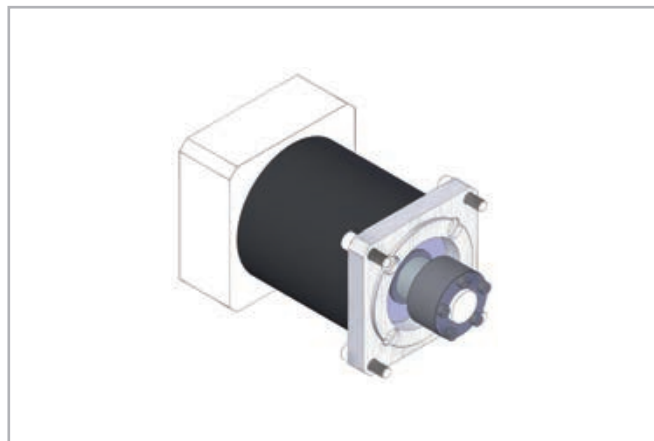

Fig. 19

Assembly kit includes: shrink disk; adapter plate; fixing hardware

Unit type	Gearbox type (not included)	Kit Code
<b>E-SMART 30</b>	MP053	G000356
	LC050; LPO50; PE2	G000357
	SW030	G000383
<b>E-SMART 50</b>	MP060; PLE60	G000852
	LC070; MPV00; LPO70; PE3	G000853
	SW040	G000854
<b>E-SMART 80</b>	P3	G000824
	MP080	G000826
	LC090; MPV01; LPO90; PE4	G000827
	MP105	G000830
	PE3; LPO70; LC070	G001078
	SPO75; PLN090	G000859
	SPO60; PLN070	G000829
	SW040	G000866
	SW050	G000895
<b>E-SMART 100</b>	MP130	G000482
	LC120; MPV02; LP120; PE5	G000483
	LC090; PE4; LPO90	G000525
	MP105	G000527
	SW050	G000717

Tab. 37

For other gearbox type ask Rollon

# Ordering key

## > Identification codes for the E-SMART linear unit

L	10	2Y	02000	2A	
	03 = 30				
	05 = 50				Type (30) 2S=SP2
	08 = 80				Type (50-80) 1T=SP1 - 2T=SP2 - 3T=SP3 - 4T=SP4
10 = 100		Type (100) 1A=SP1 - 2A=SP2 - 3A=SP3 - 4A=SP4			
			L=total length of the unit		
			Drive head code <i>see pg. SS-12</i>		
			Linear unit type <i>see from pg. SS-5 to pg. SS-10</i>		
			Linear unit series E-SMART <i>see pg. SS-2</i>		

In order to create identification codes for Actuator Line, you can visit: <http://configureactuator.rollon.com>



### Left / right orientation

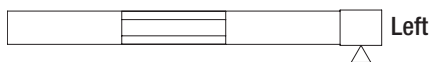

## R-SMART series



### > R-SMART series description

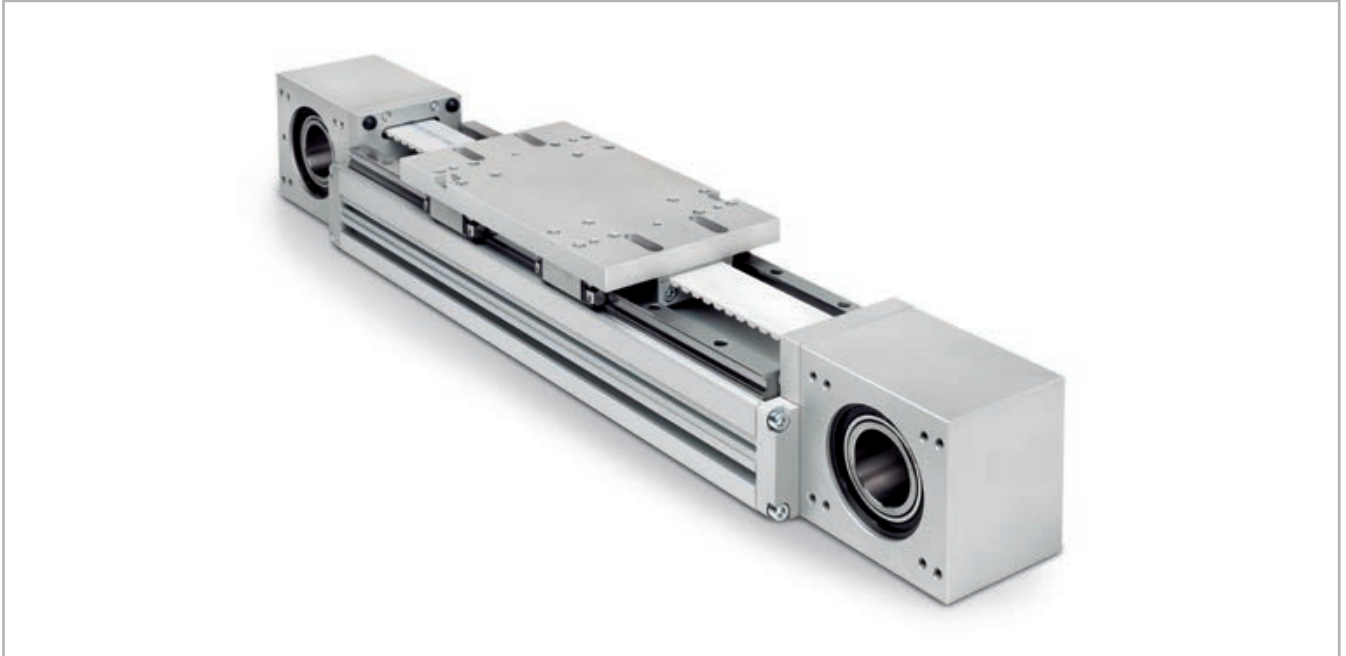

Fig. 20

#### R-SMART

The R-SMART series linear units are particularly suitable for: heavy loads, pulling and pushing very heavy weights, demanding work cycles, possible cantilever or gantry mounting, and operation in industrial automated lines.

The extruded and anodized aluminum self-supporting structure with a rectangular section is available in three sizes ranging from 120 to 220 mm. Transmission is achieved with a polyurethane steel reinforced driving belt. Also featured is a dual rail system with four or more recirculating ball bearing runner blocks. Multiple sliders are available to further improve load capacity.

These units are best used in applications requiring very heavy loads in extremely confined spaces, and where machines cannot be stopped to carry out ordinary system maintenance.

## > The components

### Extruded bodies

The anodized aluminum extrusions used for the bodies of the Rollon SMART series linear units were designed and manufactured in cooperation with a leading company in this field to obtain the right combination of high mechanical strength and reduced weight. The anodized aluminum alloy 6060 used (see physical chemical characteristics below for further information) was extruded with dimensional tolerances complying with EN 755-9 standards.

### Driving belt

The Rollon SMART series linear units use steel reinforced polyurethane drive belts with AT pitch. This belt is ideal due to its high load transmis-

sion characteristics, compact size, and low noise. Used in conjunction with a backlash-free pulley, smooth alternating motion can be achieved. Optimization of the maximum belt width/body dimension ratio enables the following performance characteristics to be achieved:

- **High speed**
- **Low noise**
- **Low wear**

### Carriage

The carriage of the Rollon SMART series linear units is made entirely of machined anodized aluminum. The dimensions vary depending on the type. Rollon offers multiple carriages to accommodate a vast array of applications.

### General data about aluminum used: AL 6060

Chemical composition [%]

Al	Mg	Si	Fe	Mn	Zn	Cu	Impurities
Remainder	0.35-0.60	0.30-0.60	0.30	0.10	0.10	0.10	0.05-0.15

Tab. 38

Physical characteristics

Density	Coeff. of elasticity	Coeff. of thermal expansion (20°-100°C)	Thermal conductivity (20°C)	Specific heat (0°-100°C)	Resistivity	Melting point
$\frac{\text{kg}}{\text{dm}^3}$	$\frac{\text{kN}}{\text{mm}^2}$	$\frac{10^{-6}}{\text{K}}$	$\frac{\text{W}}{\text{m} \cdot \text{K}}$	$\frac{\text{J}}{\text{kg} \cdot \text{K}}$	$\Omega \cdot \text{m} \cdot 10^{-9}$	°C
2.7	70	23.8	200	880-900	33	600-655

Tab. 39

Mechanical characteristics

Rm	Rp (02)	A	HB
$\frac{\text{N}}{\text{mm}^2}$	$\frac{\text{N}}{\text{mm}^2}$	%	—
250	200	10	75

Tab. 40

## > The linear motion system

The linear motion system has been designed to meet the load capacity, speed, and maximum acceleration conditions of a wide variety of applications. Rollon SMART series systems feature a linear motion system with ball bearing guides:

### Performance characteristics:

- The ball bearing guides with high load capacity are mounted in a dedicated seat on the aluminum body.
- The carriage of the linear unit is assembled on preloaded ball bearing blocks that enables the carriage to withstand loading in the four main directions.
- The ball bearing carriages of the SP versions are also fitted with a retention cage that eliminates "steel-steel" contact between adjacent revolving parts and prevents misalignment.
- The blocks have seals on both sides and, when necessary, an additional scraper can be fitted for very dusty conditions.

### The linear motion system described above offers:

- High speed and acceleration
- High load capacity
- High permissible bending moments
- Low friction
- Long life
- Low noise

R-SMART section

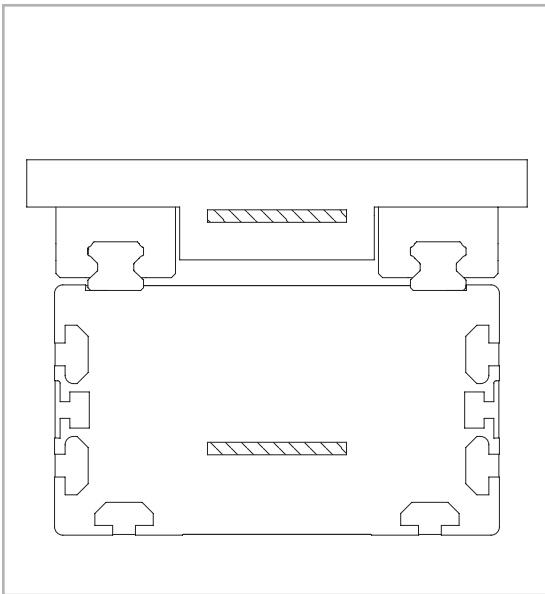
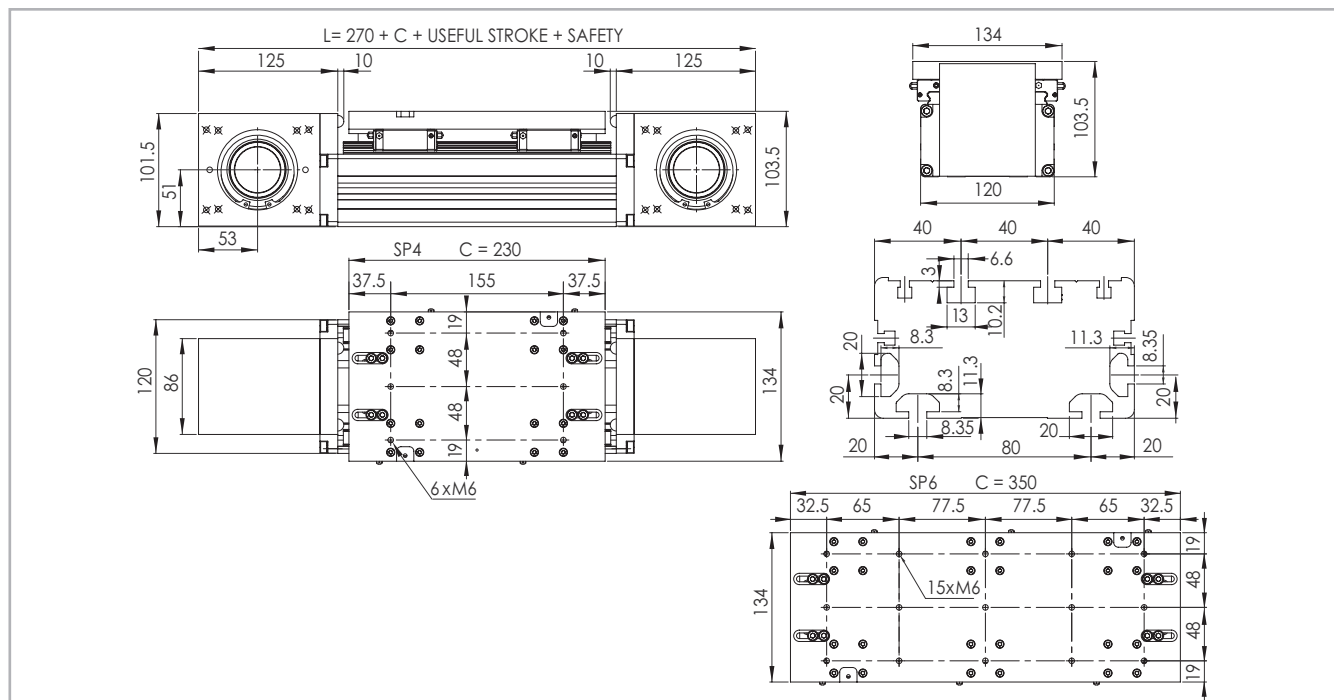

Fig. 21

## > R-SMART 120 SP4 - SP6

### R-SMART 120 Dimensions



The length of the safety stroke is provided on request according to the customer's specific requirements.

Fig. 22

### Technical data

	Type	
	R-SMART 120 SP4	R-SMART 120 SP6
Max. useful stroke length [mm]*1	6050	5930
Max. positioning repeatability [mm]*2	± 0.05	± 0.05
Max. speed [m/s]	4.0	4.0
Max. acceleration [m/s <sup>2</sup> ]	50	50
Type of belt	40 AT 10	40 AT 10
Type of pulley	Z 21	Z 21
Pulley pitch diameter [mm]	66.84	66.84
Carriage displacement per pulley turn [mm]	210	210
Carriage weight [kg]	3	4
Zero travel weight [kg]	12.9	15
Weight for 100 mm useful stroke [kg]	0.9	0.9
Starting torque [Nm]	1.95	2.3
Moment of inertia of pulleys [g · mm <sup>2</sup> ]	1.054.300	1.054.300
Rail size [mm]	15	15

Tab. 41

\*1) It is possible to obtain stroke up to 11.200 (SP4), 11.080 (SP6) by means of special Rollon joints.

\*2) Positioning repeatability is dependent on the type of transmission used.

### R-SMART 120 - Load capacity

Type	F <sub>x</sub> [N]		F <sub>y</sub> [N]		F <sub>z</sub> [N]	M <sub>x</sub> [Nm]	M <sub>y</sub> [Nm]	M <sub>z</sub> [Nm]
	Stat.	Dyn.	Stat.	Dyn.	Stat.	Stat.	Stat.	Stat.
R-SMART 120 SP4	3154	2090	96800	45082	96800	4453	6244	6244
R-SMART 120 SP6	3154	2090	145200	67623	145200	6679	11906	11906

See verification under static load and lifetime on page SL-2 and SL-3

Tab. 44

### Moments of inertia of the aluminum body

Type	I <sub>x</sub> [10 <sup>7</sup> mm <sup>4</sup> ]	I <sub>y</sub> [10 <sup>7</sup> mm <sup>4</sup> ]	I <sub>p</sub> [10 <sup>7</sup> mm <sup>4</sup> ]
R-SMART 120 SP	0.108	0.367	0.475

Tab. 42

### Driving belt

The driving belt is manufactured from a friction resistant polyurethane and with steel cords for high tensile stress resistance.

Type	Type of belt	Belt width [mm]	Weight [kg/m]
R-SMART 120 SP	40 AT 10	40	0.23

Tab. 43

$$\text{Belt length (mm)} = 2 \times L - 115 \text{ (SP4)}$$

$$2 \times L - 235 \text{ (SP6)}$$

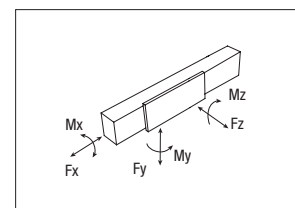

> R-SMART 160 SP4 - SP6

R-SMART 160 Dimensions

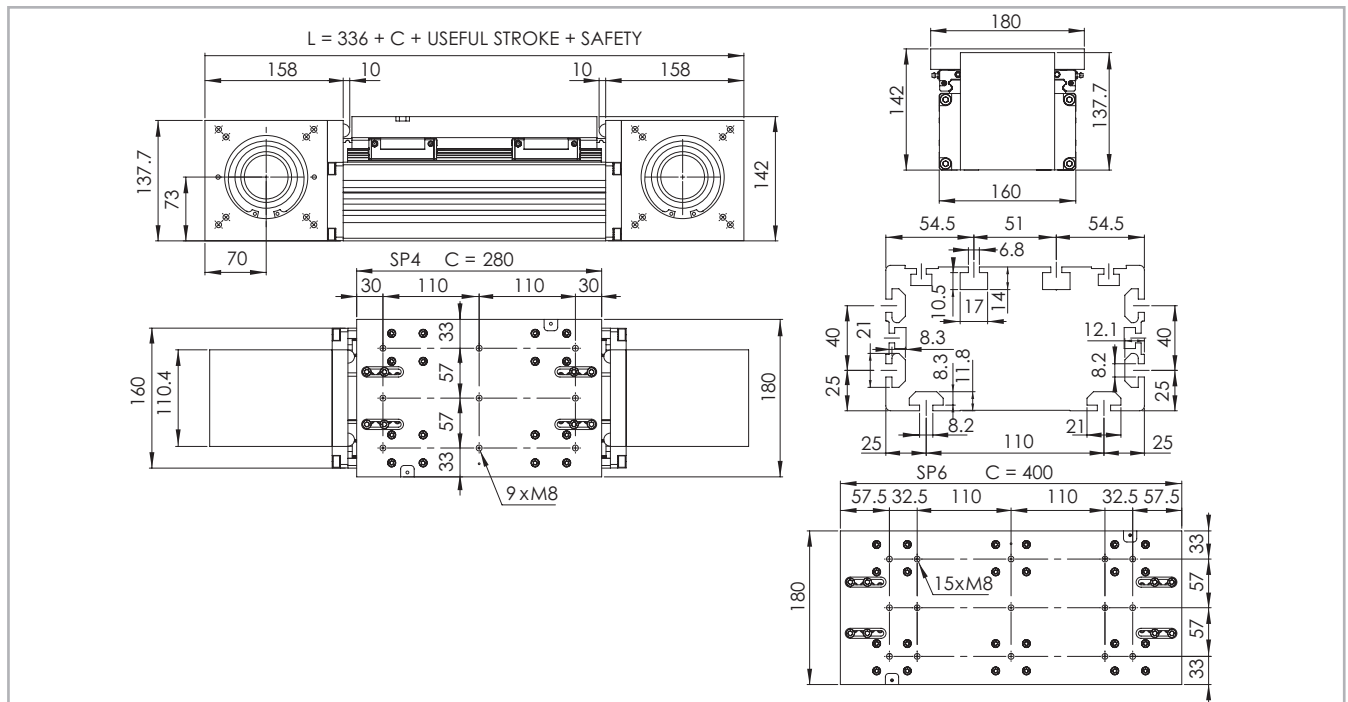

The length of the safety stroke is provided on request according to the customer's specific requirements.

Fig. 23

Technical data

	Type	
	R-SMART 160 SP4	R-SMART 160 SP6
Max. useful stroke length [mm]*1	6000	5880
Max. positioning repeatability [mm]*2	± 0.05	± 0.05
Max. speed [m/s]	4.0	4.0
Max. acceleration [m/s <sup>2</sup> ]	50	50
Type of belt	50 AT 10	50 AT 10
Type of pulley	Z 27	Z 27
Pulley pitch diameter [mm]	85.94	85.94
Carriage displacement per pulley turn [mm]	270	270
Carriage weight [kg]	5.4	7.5
Zero travel weight [kg]	24.4	27.9
Weight for 100 mm useful stroke [kg]	1.75	1.75
Starting torque [Nm]	3.4	3.95
Moment of inertia of pulleys [g · mm <sup>2</sup> ]	4.035.390	4.035.390
Rail size [mm]	20	20

\*1) It is possible to obtain stroke up to 11.200 (SP4), 11.080 (SP6) by means of special Rollon joints

\*2) The positioning repeatability depends upon the type of transmission used

Tab. 45

R-SMART 160 SP4 - R-SMART 160 SP6 - Load capacity

Type	F <sub>x</sub> [N]		F <sub>y</sub> [N]		F <sub>z</sub> [N]	M <sub>x</sub> [Nm]	M <sub>y</sub> [Nm]	M <sub>z</sub> [Nm]
	Stat.	Dyn.	Stat.	Dyn.	Stat.	Stat.	Stat.	Stat.
R-SMART 160 SP4	4980	3390	153600	70798	153600	8909	12595	12595
R-SMART 160 SP6	4980	3390	230400	106197	230400	13363	21427	21427

See verification under static load and lifetime on page SL-2 and SL-3

Moments of inertia of the aluminum body

Type	I <sub>x</sub> [10 <sup>7</sup> mm <sup>4</sup> ]	I <sub>y</sub> [10 <sup>7</sup> mm <sup>4</sup> ]	I <sub>p</sub> [10 <sup>7</sup> mm <sup>4</sup> ]
R-SMART 160 SP	0.383	1.313	1.696

Tab. 46

Driving belt

The driving belt is manufactured from a friction resistant polyurethane and with steel cords for high tensile stress resistance.

Type	Type of belt	Belt width [mm]	Weight [kg/m]
R-SMART 160 SP	50 AT 10	50	0.29

Tab. 47

Belt length (mm) = 2 x L - 150 (SP4)  
2 x L - 270 (SP6)

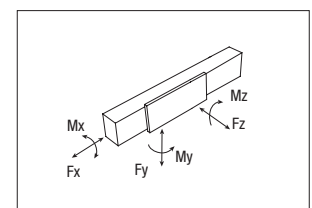

Tab. 48  
SS-21



> R-SMART 220 SP4- SP6

R-SMART 220 Dimensions

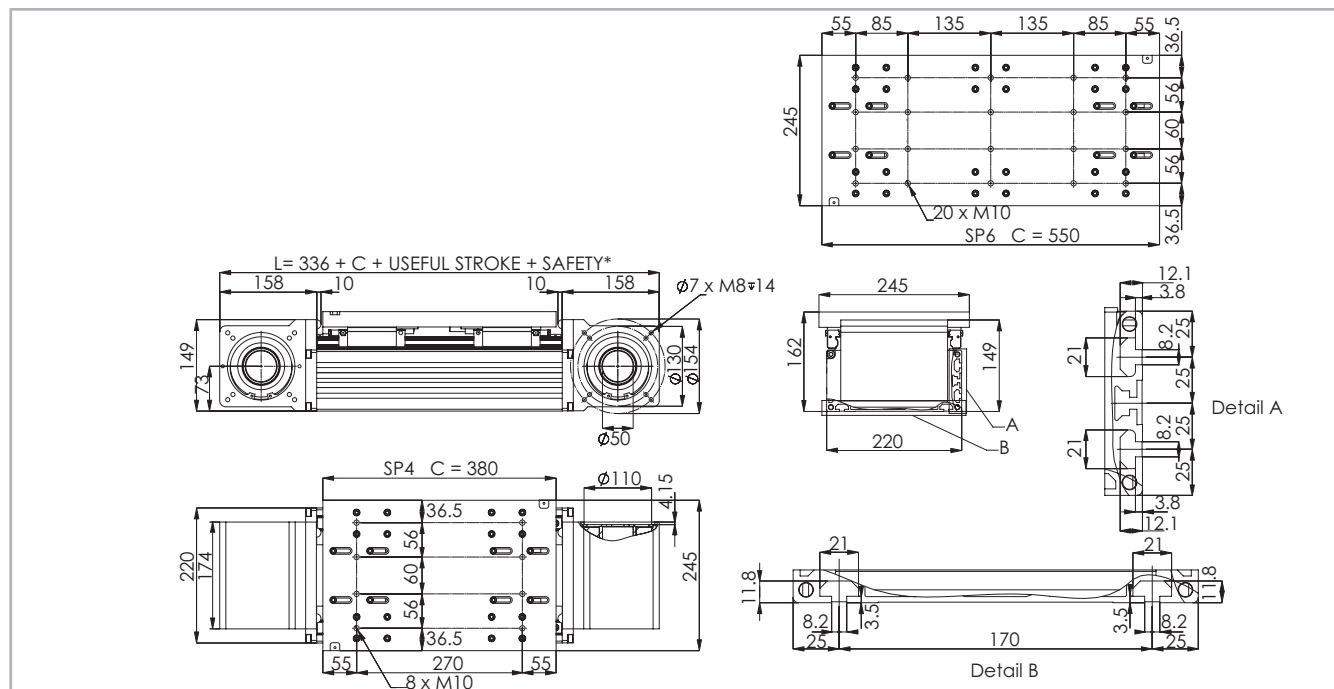

The length of the safety stroke is provided on request according to the customer's specific requirements.

Fig. 24

Technical data

	Type	
	R-SMART 220 SP4	R-SMART 220 SP6
Max. useful stroke length [mm]*1	5900	5730
Max. positioning repeatability [mm]*2	$\pm 0.05$	$\pm 0.05$
Max. speed [m/s]	4.0	4.0
Max. acceleration [m/s <sup>2</sup> ]	50	50
Type of belt	100 AT 10	100 AT 10
Type of pulley	Z 32	Z 32
Pulley pitch diameter [mm]	101.86	101.86
Carriage displacement per pulley turn [mm]	320	320
Carriage weight [kg]	12.1	16.95
Zero travel weight [kg]	41.13	49.93
Weight for 100 mm useful stroke [kg]	2.45	2.45
Starting torque [Nm]	4.3	7
Moment of inertia of pulleys [g · mm <sup>2</sup> ]	12.529.220	12.529.220
Rail size [mm]	25	25

Tab. 49

\*1) It is possible to obtain stroke up to 11.100 (SP4), 10.930 (SP6) by means of special Rollon joints.

\*2) Positioning repeatability is dependent on the type of transmission used.

R-SMART 220 SP4 - R-SMART 220 SP6 - Load capacity

Type	F <sub>x</sub> [N]		F <sub>y</sub> [N]		F <sub>z</sub> [N]	M <sub>x</sub> [Nm]	M <sub>y</sub> [Nm]	M <sub>z</sub> [Nm]
	Stat.	Dyn.	Stat.	Dyn.	Stat.	Stat.	Stat.	Stat.
R-SMART 220 SP4	9960	7380	258800	116833	258800	21998	28468	28468
R-SMART 220 SP6	9960	7380	388200	175249	388200	32997	50466	50466

See verification under static load and lifetime on page SL-2 and SL-3

Tab. 52

Moments of inertia of the aluminum body

Type	I <sub>x</sub> [10 <sup>7</sup> mm <sup>4</sup> ]	I <sub>y</sub> [10 <sup>7</sup> mm <sup>4</sup> ]	I <sub>p</sub> [10 <sup>7</sup> mm <sup>4</sup> ]
R-SMART 220 SP	0.663	3.658	4.321

Tab. 50

Driving belt

The driving belt is manufactured from a friction resistant polyurethane and with steel cords for high tensile stress resistance.

Type	Type of belt	Belt width [mm]	Weight [kg/m]
R-SMART 220 SP	100 AT 10	100	0.58

Tab. 51

Belt length (mm) = 2 x L - 130 (SP4)

2 x L - 300 (SP6)

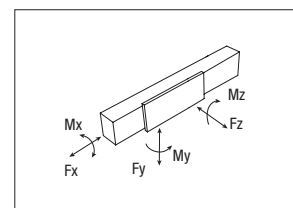

## > Lubrication

### SP linear units with ball bearing guides

SP Linear units are equipped with self lubricating linear ball guides. The ball bearing carriages of the SP versions are also fitted with a retention cage that eliminates "steel-steel" contact between adjacent revolving parts and prevents misalignment.

This system guarantees a long interval between maintenances: SP version: every 2000 Km or 1 year of use, based on the value reached first. If

a longer service life is required or in case of high dynamic or high loaded applications please contact our offices for further verification.

### R-SMART

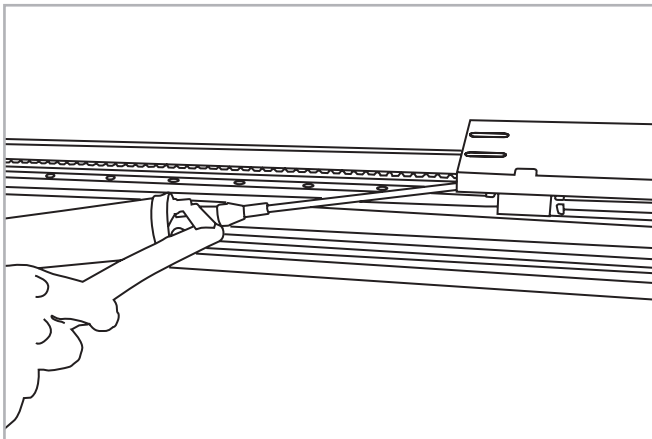

Fig. 25

- Insert the tip of the grease gun into the specific grease blocks.
- Type of lubricant: Lithium soap grease of class NLGI 2.
- For specially stressed applications or hostile environmental conditions, lubrication should be applied out more frequently.  
Contact Rollon for further advice

Quantity of lubricant necessary for re-lubrication of each block:

Type	Quantity of Grease [cm <sup>3</sup> ]
R-SMART 120	0.7
R-SMART 160	1.4
R-SMART 220	2.4

Tab. 53

## > Simple shafts

### AS type simple shafts

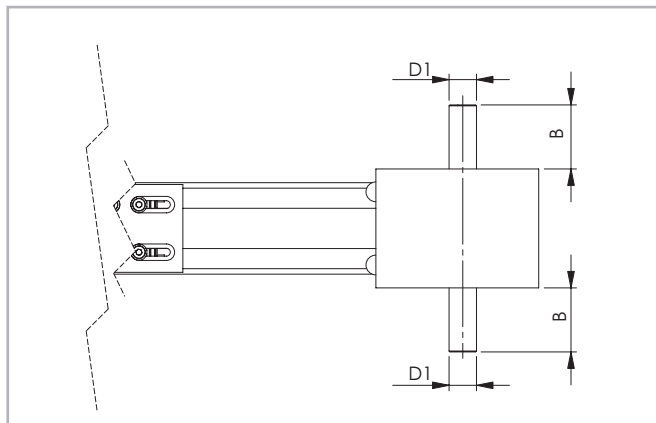

Position of the simple shaft can be to the right or to the left of the drive head.

Fig. 26

This head configuration is obtained by utilizing an assembly kit delivered as a separate accessory item.

Shaft can be installed on the left or right side of the drive head as decided by the customer.

### Units (mm)

Applicable to unit	Shaft type	B	D1	AS assembly kit code
R-SMART 120	AS 20	36	20h7	G000828
R-SMART 160	AS 25	50	25h7	G000649
R-SMART 220	AS 25	50	25h7	G000649

Tab. 54

## > Hollow shaft

### Hollow shaft type FP - Standard supply

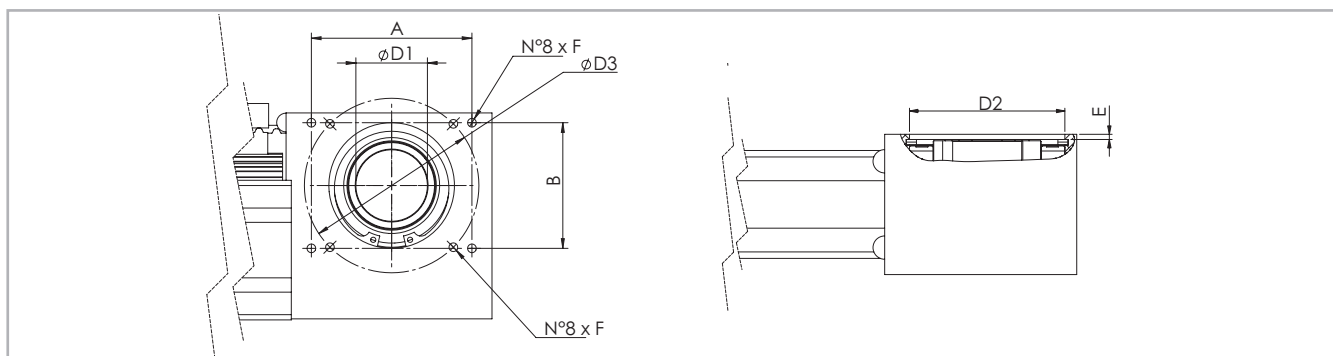

Fig. 27

### Units (mm)

Applicable to unit	Shaft type	D1	D2	D3	E	F	A x B	Drive head code
R-SMART 120	FP 41	41H7	72	100	3.5	M6	92x72	2Y
R-SMART 160	FP 50	50H7	95	130	3.5	M8	109x109	2Y
R-SMART 220	FP 50	50H7	110	130	4	M8	109x109	2Y

Tab. 55

An (optional) connection flange is required to fit the standard reduction units selected by Rollon.

For further information contact our offices.

## > Accessories

### Fixing by brackets

The ball bearing guide linear drive system of Rollon SMART System series linear units enables them to support loads in any direction. They can therefore be installed in any position.

To install the SMART System series units, we recommend use of one of the systems indicated below:

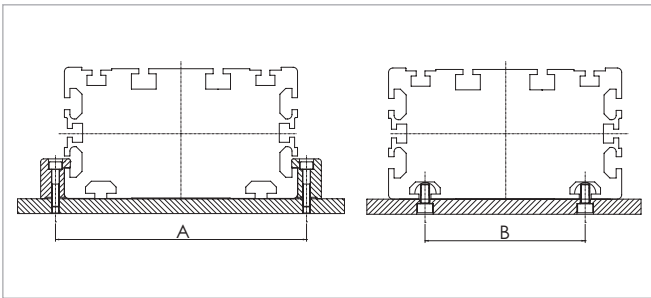

Fig. 28

### Units (mm)

	A	B
R-SMART 120	132	80
R-SMART 160	180	110
R-SMART 220	240	170

Tab. 56

### Fixing brackets

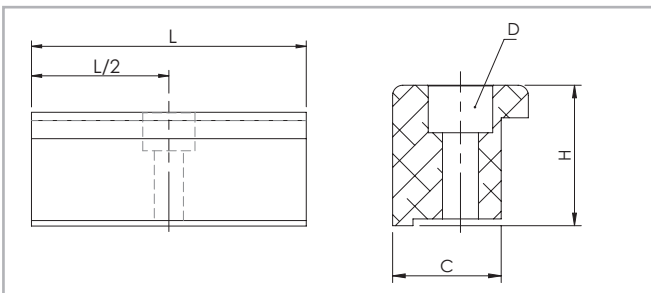

Fig. 29

### Dimensions (mm)

	C	H	L	D	Code Rollon
R-SMART 120	16	20.7	50	M5	1000111
R-SMART 160	31	28.5	100	M10	1002377
R-SMART 220	31	28.5	100	M10	1002377

Tab. 57

### T-nuts

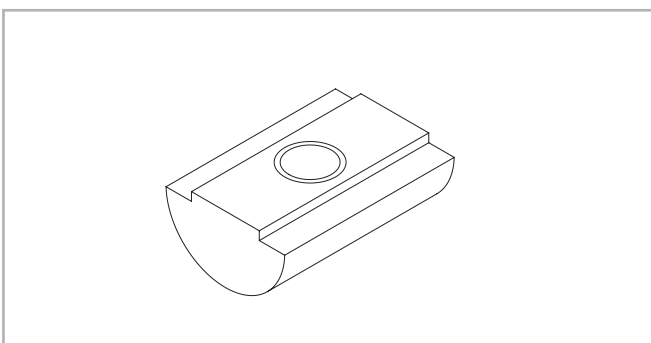

Steel nuts to be used in the slots of the body.

Fig. 30

### Units (mm)

	Hole	Length	Code Rollon
R-SMART 120	M6	20	6000437
R-SMART 160	M6	20	6000437
R-SMART 160	M8	20	6001544
R-SMART 220	M6	20	6000437
R-SMART 220	M8	20	6001544

Tab. 58

Proximity

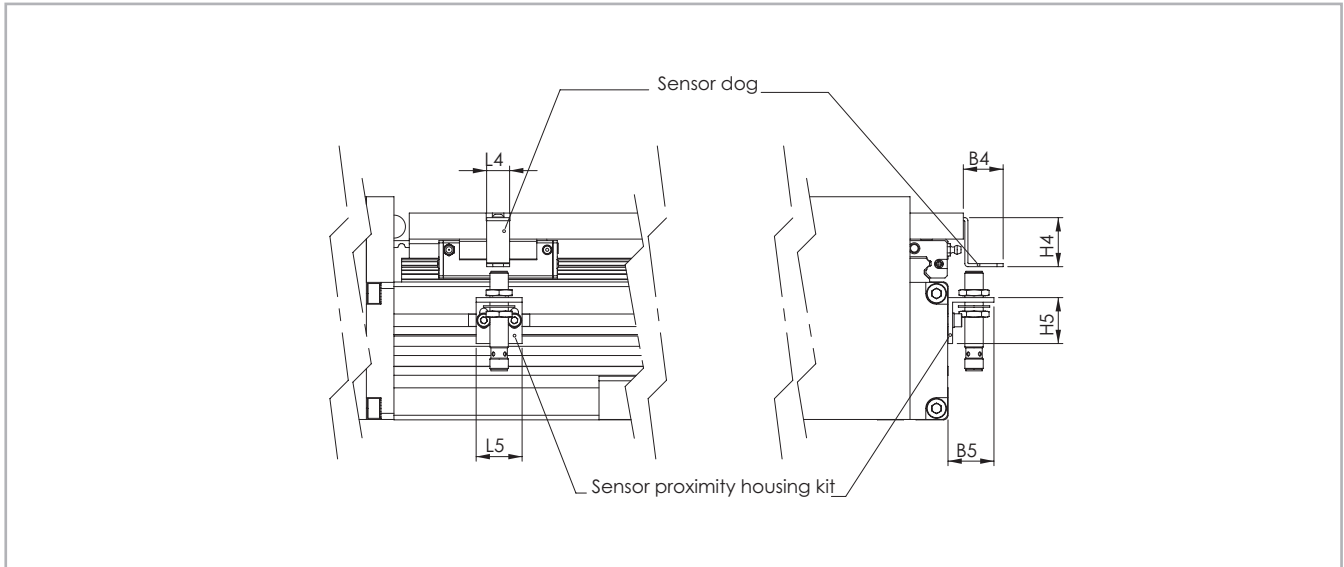

Fig. 31

**Sensor proximity housing kit**

Aluminum block equipped with T-nuts for fixing

**Sensor dog**

Iron plate mounted on the carriage used for the proximity operation

Units (mm)

	B4	B5	L4	L5	H4	H5	For proximity	Sensor dog	Sensor proximity housing kit
R-SMART 120	26	30	15	30	32	30	Ø 8	G000833	G000844
R-SMART 160	26	30	15	30	32	30	Ø 8	G000833	G000838
R-SMART 220	26	30	15	30	32	30	Ø 8	G000833	G000838

Tab. 59

Assembly kits

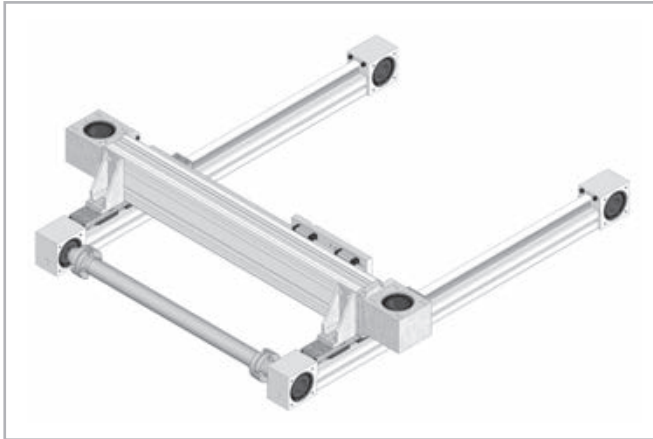

Fig. 32



Fig. 33

For the direct assembly of R-SMART linear units on other types of actuators Rollon offers dedicated assembly kits. The table below shows the allowed combinations as well as the assembly kit codes.

	Kit	Code	X No rail at each end (mm)
	R-SMART 120 on E-SMART 50	G000899*	60
	R-SMART 120 on E-SMART 80	G000863*	90
	R-SMART 160 on E-SMART 80	G000902*	90
	R-SMART 160 on E-SMART 100	G000903*	110
	R-SMART 220 on E-SMART 100	G001207	110

\* Additional fixing holes are requested on the E-SMART plate.

Tab. 60

Adapter flange for gearbox assembly

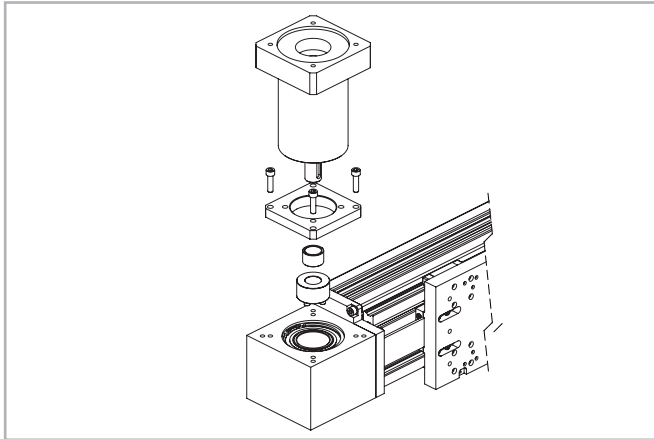

Fig. 34

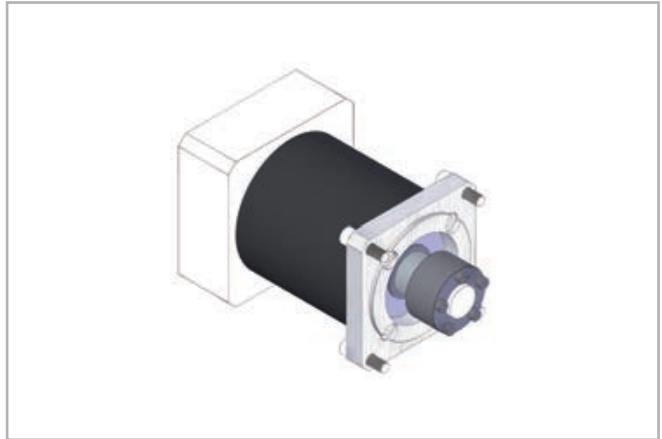

Fig. 35

Assembly kit includes: shrink disk; adapter plate; fixing hardware

Unit type	Gearbox type (not included)	Kit Code
R-SMART 120	P3	G000824
	MP080	G000826
	LC90; MPV01; LP090; PE4	G000827
	MP105	G000830
	PE3; LP070; LC070	G001078
	SP060; PLN070	G000829
	SP070; PLN090	G000859
	SW040	G000866
R-SMART 160	MP130	G000482
	LC120; MPV02; LP120; PE5	G000483
	LC090; LP090; PE4	G000525
	MP105	G000527
	SP075; PLN090	G000526
	SW050	G000717
R-SMART 220	MP130	G001045
	MP105	G001047
	LC120; MPV02; LP120; PE5	G001049

Tab. 61

For other gearbox type ask Rollon

# Ordering key

## > Identification codes for the R-SMART linear unit

D	12 12=120 16=160 22=220	2Y	02000	4A	
				Type (120-160-220) 4A=SP4 6A=SP6	
				L=total length of the unit	
				Drive head code <i>see pg. SS-24</i>	
				Linear unit type <i>see from pg. SS-20 to pg. SS-22</i>	
Linear unit series R-SMART <i>see pg. SS-17</i>					

In order to create identification codes for Actuator Line, you can visit: <http://configureactuator.rollon.com>



### Left / right orientation

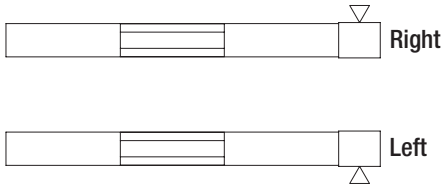



## S-SMART series



### > S-SMART series description



Fig. 36

#### **S-SMART**

The S-SMART series linear units were designed to meet the vertical motion requirements in gantry applications or for applications where the aluminum profile must be moving and the carriage must be fixed.

The self-supporting extruded and anodized aluminum structure is available in three sizes. Since it is a rigid system, it is ideal for a "Z" axis in a 3-axis system by using a linear guide rail.

In addition, the S-SMART series has been specifically designed and configured to be easily assembled with the R-SMART series by using a simple bracket.

## > The components

### Extruded profile

The anodized aluminum extrusions used for the bodies of the Rollon SMART series linear units were designed and manufactured in cooperation with a leading company in this field to obtain the right combination of high mechanical strength and reduced weight. The anodized aluminum alloy 6060 used (see physical chemical characteristics below for further information) was extruded with dimensional tolerances complying with EN 755-9 standards.

### Driving belt

The Rollon SMART series linear units use steel reinforced polyurethane drive belts with AT pitch. This belt is ideal due to its high load transmission

characteristics, compact size and low noise. Used in conjunction with a backlash-free pulley, smooth alternating motion can be achieved. Optimization of the maximum belt width/body dimension ratio enables the following performance characteristics to be achieved:

- High speed
- Low noise
- Low wear

### Carriage

The carriage of the Rollon SMART series linear units is made entirely of anodized aluminum. The dimensions vary depending on the type.

### General data about aluminum used: AL 6060

Chemical composition [%]

Al	Mg	Si	Fe	Mn	Zn	Cu	Impurities
Remainder	0.35-0.60	0.30-0.60	0.30	0.10	0.10	0.10	0.05-0.15

Tab. 62

Physical characteristics

Density	Coeff. of elasticity	Coeff. of thermal expansion (20°-100°C)	Thermal conductivity (20°C)	Specific heat (0°-100°C)	Resistivity	Melting point
$\frac{\text{kg}}{\text{dm}^3}$	$\frac{\text{kN}}{\text{mm}^2}$	$\frac{10^{-6}}{\text{K}}$	$\frac{\text{W}}{\text{m} \cdot \text{K}}$	$\frac{\text{J}}{\text{kg} \cdot \text{K}}$	$\Omega \cdot \text{m} \cdot 10^{-9}$	°C
2.7	70	23.8	200	880-900	33	600-655

Tab. 63

Mechanical characteristics

Rm	Rp (02)	A	HB
$\frac{\text{N}}{\text{mm}^2}$	$\frac{\text{N}}{\text{mm}^2}$	%	—
250	200	10	75

Tab. 64

## > The linear motion system

The linear motion system has been designed to meet the load capacity, speed, and maximum acceleration conditions of a wide variety of applications. Rollon SMART System series systems feature a linear motion system with ball bearing guides:

### Performance characteristics:

- The ball bearing guides with high load capacity are mounted in a dedicated seat on the aluminum body.
- The carriage of the linear unit is assembled on pre-loaded ball bearing blocks that enables the carriage to withstand loading in the four main directions.
- The ball bearing carriages of the SP versions are also fitted with a retention cage that eliminates "steel-steel" contact between adjacent revolving parts and prevents misalignment.
- The blocks have seals on both sides and, when necessary, an additional scraper can be fitted for very dusty conditions.

### The linear motion system described above offers:

- High speed and acceleration
- High load capacity
- High permissible bending moments
- Low friction
- Long life
- Low noise

### S-SMART section

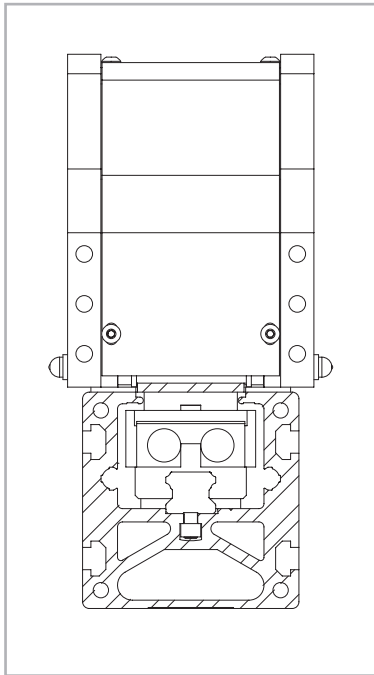
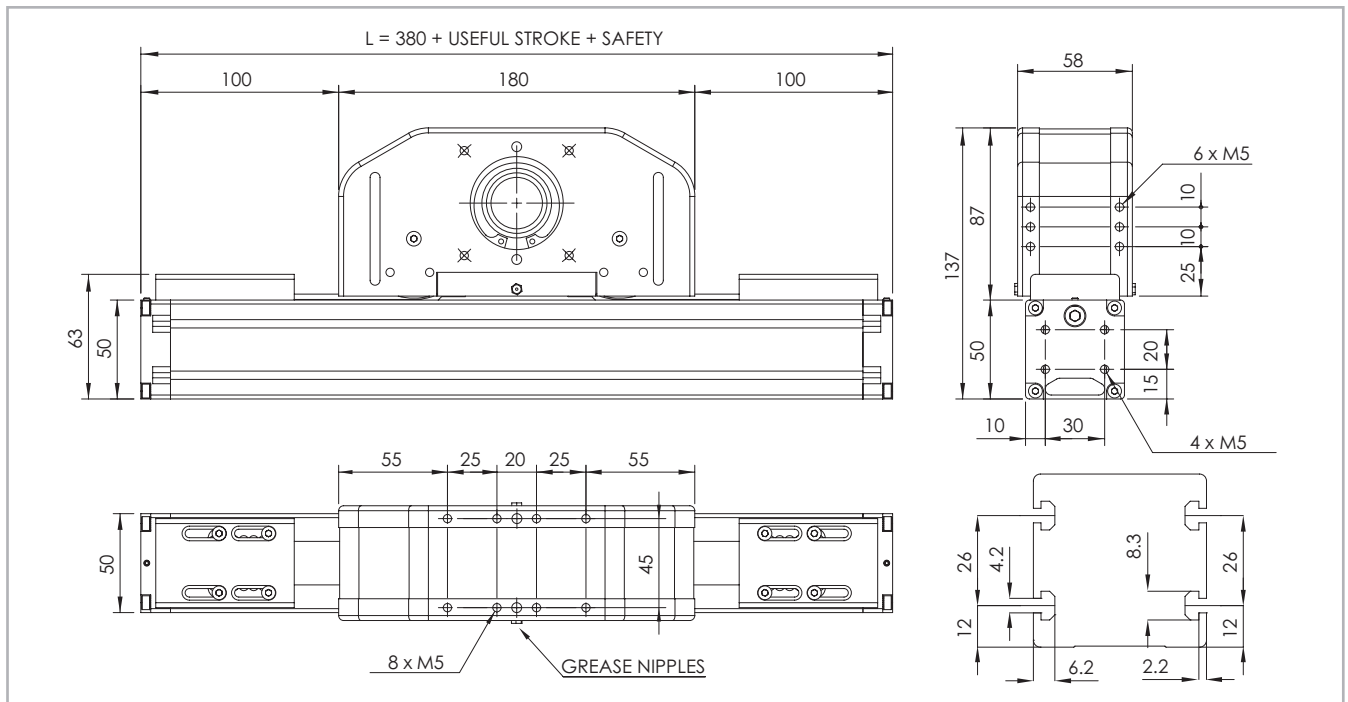

Fig. 37

> S-SMART 50 SP

S-SMART 50 SP Dimensions



The length of the safety stroke is provided on request according to the customer's specific requirements.

Fig. 38

Technical data

	Type
	S-SMART 50 SP
Max. useful stroke length [mm]	1000
Max. positioning repeatability [mm]*1	± 0.05
Max. speed [m/s]	4.0
Max. acceleration [m/s <sup>2</sup> ]	50
Type of belt	22 AT 5
Type of pulley	Z 23
Pulley pitch diameter [mm]	36.61
Carriage displacement per pulley turn [mm]	115
Carriage weight [kg]	2
Zero travel weight [kg]	5.7
Weight for 100 mm useful stroke [kg]	0.4
Starting torque [Nm]	0.25
Rail size [mm]	12 mini

\*1) Positioning repeatability is dependent on the type of transmission used

Tab. 65

S-SMART 50 SP - Load capacity

Type	F <sub>x</sub> [N]		F <sub>y</sub> [N]		F <sub>z</sub> [N]	M <sub>x</sub> [Nm]	M <sub>y</sub> [Nm]	M <sub>z</sub> [Nm]
	Stat.	Dyn.	Stat.	Dyn.	Stat.	Stat.	Stat.	Stat.
S-SMART 50 SP	809	508	7060	6350	7060	46.2	233	233

See verification under static load and lifetime on page SL-2 and SL-3

Tab. 68

Moments of inertia of the aluminum body

Type	I <sub>x</sub> [10 <sup>7</sup> mm <sup>4</sup> ]	I <sub>y</sub> [10 <sup>7</sup> mm <sup>4</sup> ]	I <sub>p</sub> [10 <sup>7</sup> mm <sup>4</sup> ]
S-SMART 50 SP	0.025	0.031	0.056

Tab. 66

Driving belt

The driving belt is manufactured from a friction resistant polyurethane and with steel cords for high tensile stress resistance.

Type	Type of belt	Belt width [mm]	Weight [kg/m]
S-SMART 50 SP	22 AT 5	22	0.072

Tab. 67

Belt length (mm) = L + 30

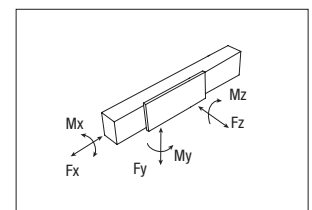

**S-SMART 65 SP**

**S-SMART 65 SP Dimensions**

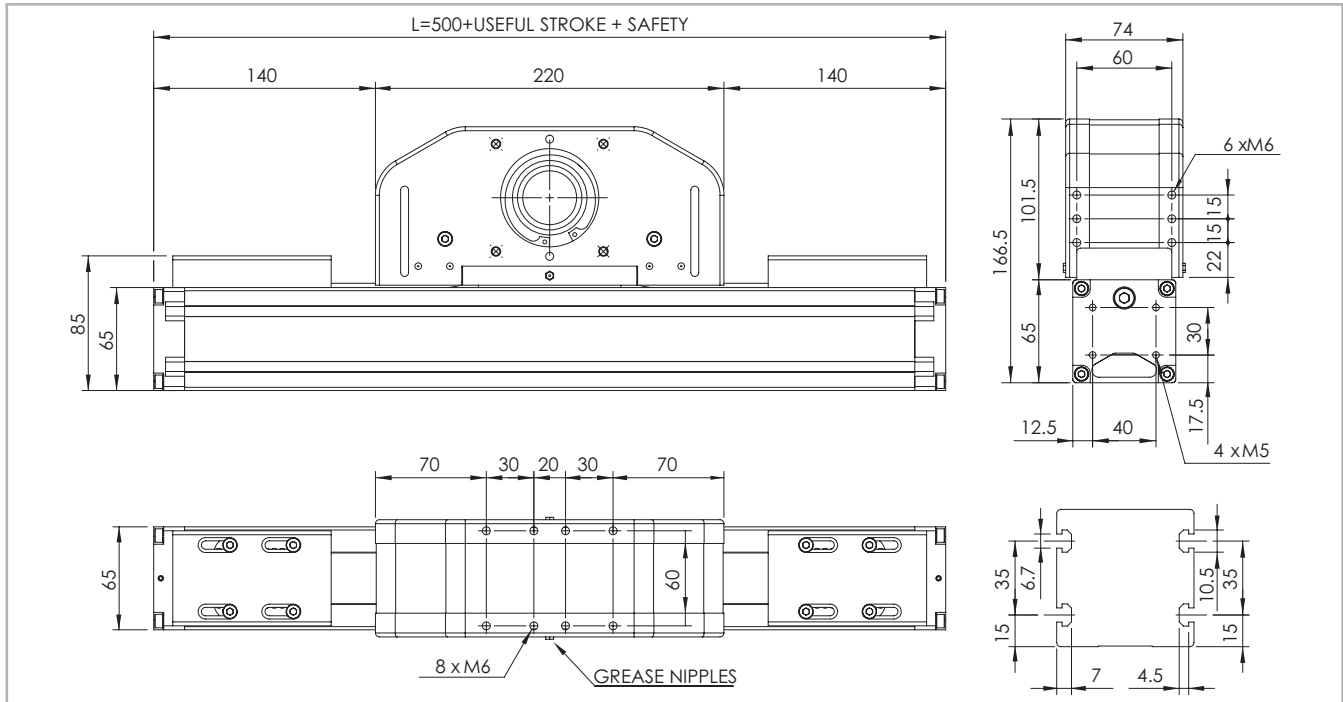

The length of the safety stroke is provided on request according to the customer's specific requirements.

Fig. 39

**Technical data**

	Type
	S-SMART 65 SP
Max. useful stroke length [mm]	1500
Max. positioning repeatability [mm]*1	± 0.05
Max. speed [m/s]	4.0
Max. acceleration [m/s <sup>2</sup> ]	50
Type of belt	32 AT 5
Type of pulley	Z 32
Pulley pitch diameter [mm]	50.93
Carriage displacement per pulley turn [mm]	160
Carriage weight [kg]	3.6
Zero travel weight [kg]	7.3
Weight for 100 mm useful stroke [kg]	0.6
Starting torque [Nm]	0.60
Rail size [mm]	15

\*1) Positioning repeatability is dependent on the type of transmission used

Tab. 69

**S-SMART 65 SP - Load capacity**

Type	F <sub>x</sub> [N]		F <sub>y</sub> [N]		F <sub>z</sub> [N]	M <sub>x</sub> [Nm]	M <sub>y</sub> [Nm]	M <sub>z</sub> [Nm]
	Stat.	Dyn.	Stat.	Dyn.	Stat.	Stat.	Stat.	Stat.
S-SMART 65 SP	1344	960	30560	19890	30560	240	1213	1213

See verification under static load and lifetime on page SL-2 and SL-3

Tab. 72

**Moments of inertia of the aluminum body**

Type	I <sub>x</sub> [10 <sup>7</sup> mm <sup>4</sup> ]	I <sub>y</sub> [10 <sup>7</sup> mm <sup>4</sup> ]	I <sub>p</sub> [10 <sup>7</sup> mm <sup>4</sup> ]
S-SMART 65 SP	0.060	0.086	0.146

Tab. 70

**Driving belt**

The driving belt is manufactured from a friction resistant polyurethane and with steel cords for high tensile stress resistance.

Type	Type of belt	Belt width [mm]	Weight [kg/m]
S-SMART 65 SP	32 AT 5	32	0.105

Tab. 71

Belt length (mm) = L + 35

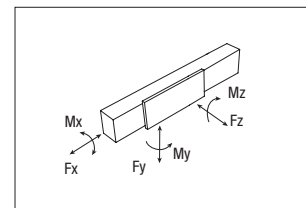

> S-SMART 80 SP

S-SMART 80 SP Dimensions

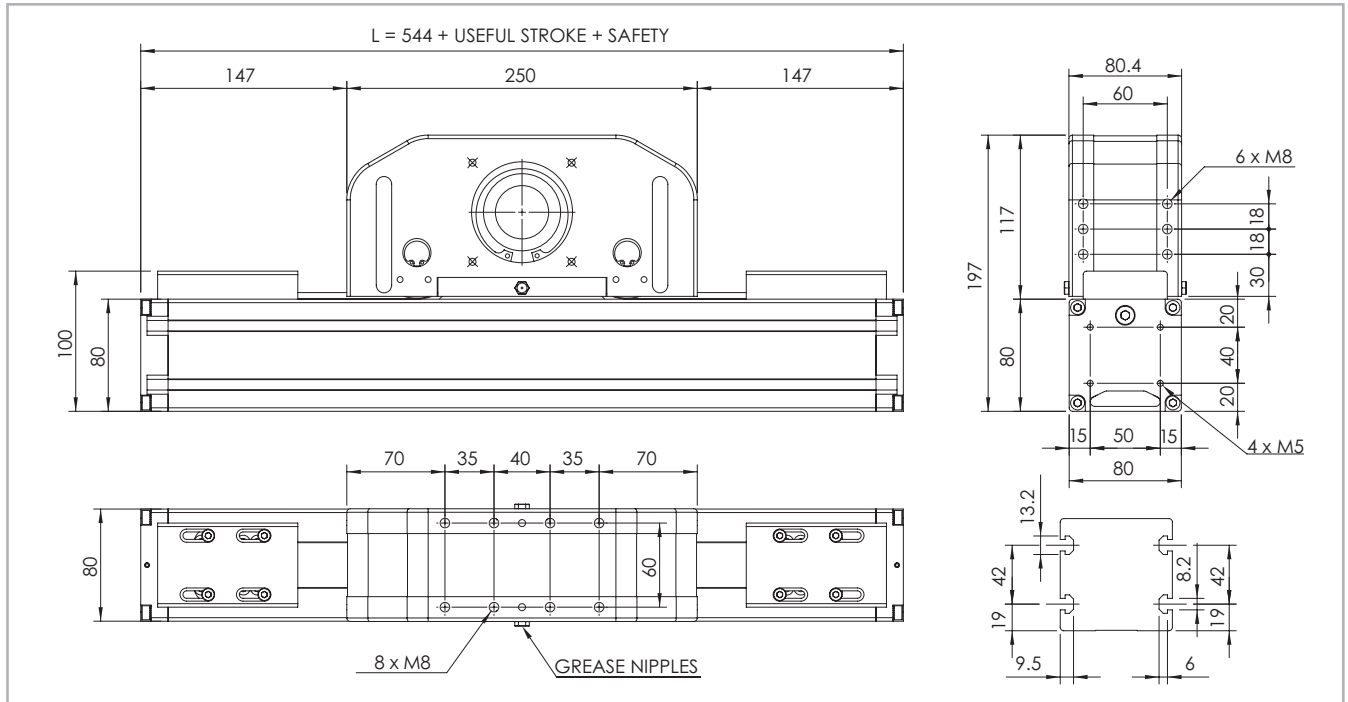

The length of the safety stroke is provided on request according to the customer's specific requirements.

Fig. 40

Technical data

	Type
	S-SMART 80 SP
Max. useful stroke length [mm]	2000
Max. positioning repeatability [mm]*1	± 0.05
Max. speed [m/s]	4.0
Max. acceleration [m/s <sup>2</sup> ]	50
Type of belt	32 AT 10
Type of pulley	Z 21
Pulley pitch diameter [mm]	66.85
Carriage displacement per pulley turn [mm]	210
Carriage weight [kg]	6.3
Zero travel weight [kg]	12.6
Weight for 100 mm useful stroke [kg]	1
Starting torque [Nm]	1.65
Rail size [mm]	20

\*1) Positioning repeatability is dependent on the type of transmission used

Tab. 73

S-SMART 80 SP - Load capacity

Type	F <sub>x</sub> [N]		F <sub>y</sub> [N]		F <sub>z</sub> [N]	M <sub>x</sub> [Nm]	M <sub>y</sub> [Nm]	M <sub>z</sub> [Nm]
	Stat.	Dyn.	Stat.	Dyn.	Stat.	Stat.	Stat.	Stat.
S-SMART 80 SP	2523	1672	51260	36637	51260	520	3742	3742

See verification under static load and lifetime on page SL-2 and SL-3

Tab. 76

Moments of inertia of the aluminum body

Type	I <sub>x</sub> [10 <sup>7</sup> mm <sup>4</sup> ]	I <sub>y</sub> [10 <sup>7</sup> mm <sup>4</sup> ]	I <sub>p</sub> [10 <sup>7</sup> mm <sup>4</sup> ]
S-SMART 80 SP	0.136	0.195	0.331

Tab. 74

Driving belt

The driving belt is manufactured from a friction resistant polyurethane and with steel cords for high tensile stress resistance.

Type	Type of belt	Belt width [mm]	Weight [kg/m]
S-SMART 80 SP	32 AT 10	32	0.186

Tab. 75

Belt length (mm) = L + 50

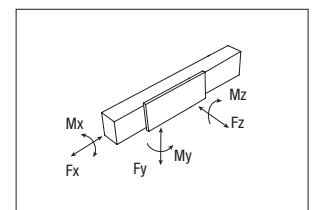

## > Lubrication

### SP linear units with ball bearing guides

The ball bearing carriages of the SP versions are fitted with a retention cage that eliminates "steel-steel" contact between adjacent revolving parts and prevents misalignment of these in the circuits.

This system guarantees a long interval between maintenances: SP version: every 2000 Km or 1 year of use, based on the value reached first. If

a longer service life is required or in case of high dynamic or high loaded applications please contact our offices for further verification.

### S-SMART

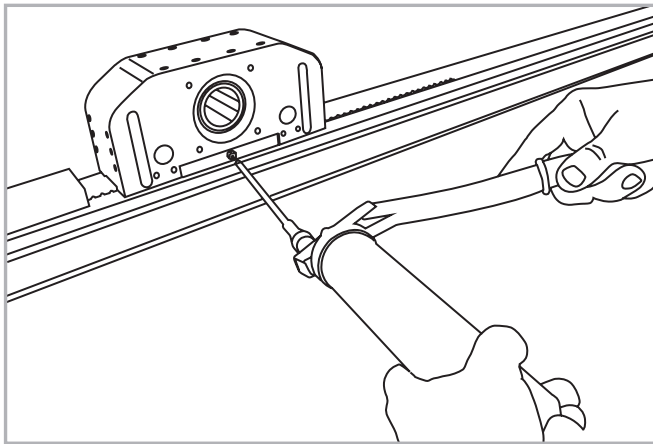

Fig. 41

- Insert the tip of the grease gun into the specific grease blocks.
- Type of lubricant: Lithium soap grease of class NLGI 2.
- For specially stressed applications or hostile environmental conditions, lubrication should be applied out more frequently.  
Contact Rollon for further advice

Quantity of lubricant necessary for re-lubrication of each block:

Type	Quantity of Grease (cm <sup>3</sup> )
S-SMART 50	0.5
S-SMART 65	0.2
S-SMART 80	0.5

Tab. 77

## > Simple shafts

### AS type simple shafts

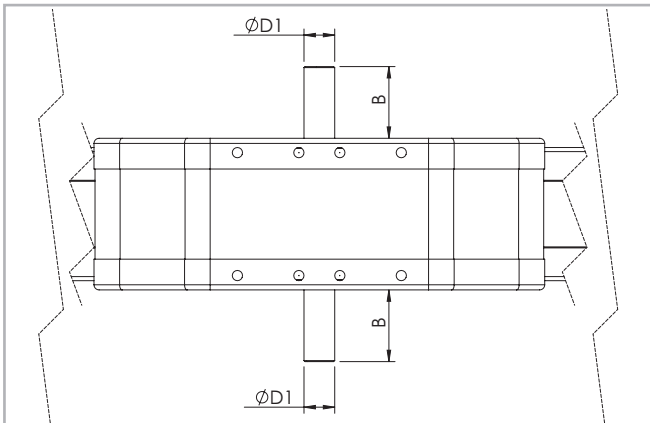

Position of the simple shaft can be to the right or to the left of the drive head.

Fig. 42

This head configuration is obtained by utilizing an assembly kit delivered as a separate accessory item.

Shaft can be installed on the left or right side of the drive head as decided by the customer.

### Units (mm)

Applicable to unit	Shaft type	B	D1	AS Assembly kit code
S-SMART 50	AS 12	26	12h7	G000652
S-SMART 65	AS 15	35	15h7	G000851
S-SMART 80	AS 20	40	20h7	G000828

Tab. 78

## > Hollow shaft

### Hollow shaft type FP - Standard supply

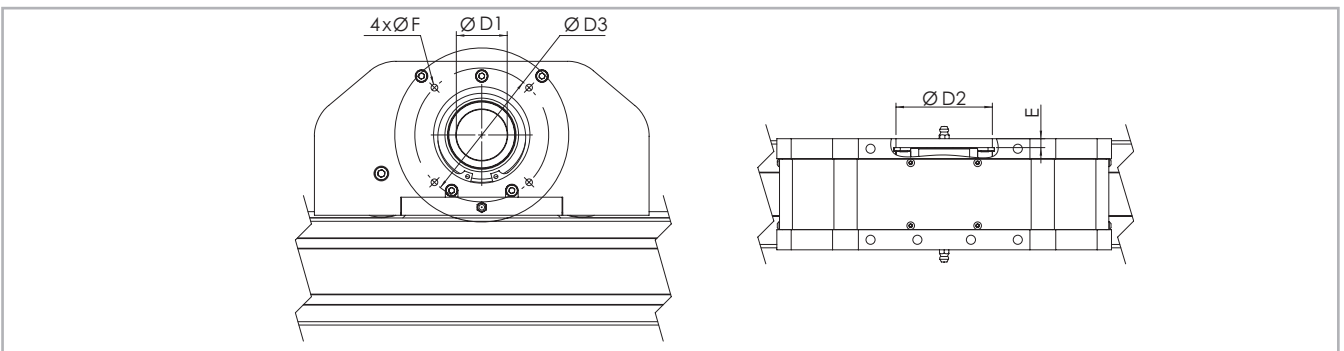

Fig. 43

### Units (mm)

Applicable to unit	Shaft type	D1	D2	D3	E	F	Drive head code
S-SMART 50	FP 26	26H7	47	75	2.5	M5	2YA
S-SMART 65	FP 34	34H7	62	96	2.5	M6	2YA
S-SMART 80	FP 41	41H7	72	100	5	M6	2ZA

Tab. 79

An (optional) connection flange is required to fit the standard reduction units selected by Rollon.

For further information contact our offices.



## > Accessories

The ball bearing guide linear drive system of Rollon SMART System series linear units enables them to support loads in any direction. They can therefore be installed in any position.

To install the SMART System series units, we recommend use of one of the systems indicated below:

### T-nuts

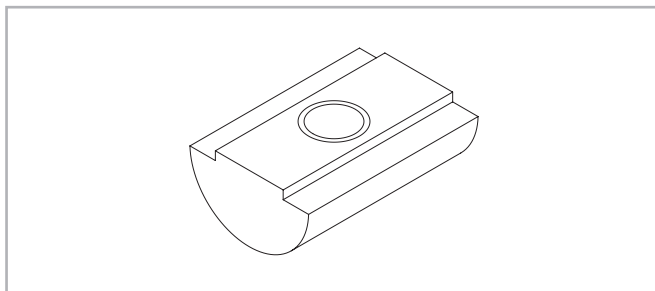

Steel nuts to be used in the slots of the body.

Fig. 44

### Units (mm)

	Hole	Length	Code Rollon
S-SMART 50	M4	8	1001046
S-SMART 65	M5	10	1000627
S-SMART 80	M6	13	1000043

Tab. 80

### Proximity

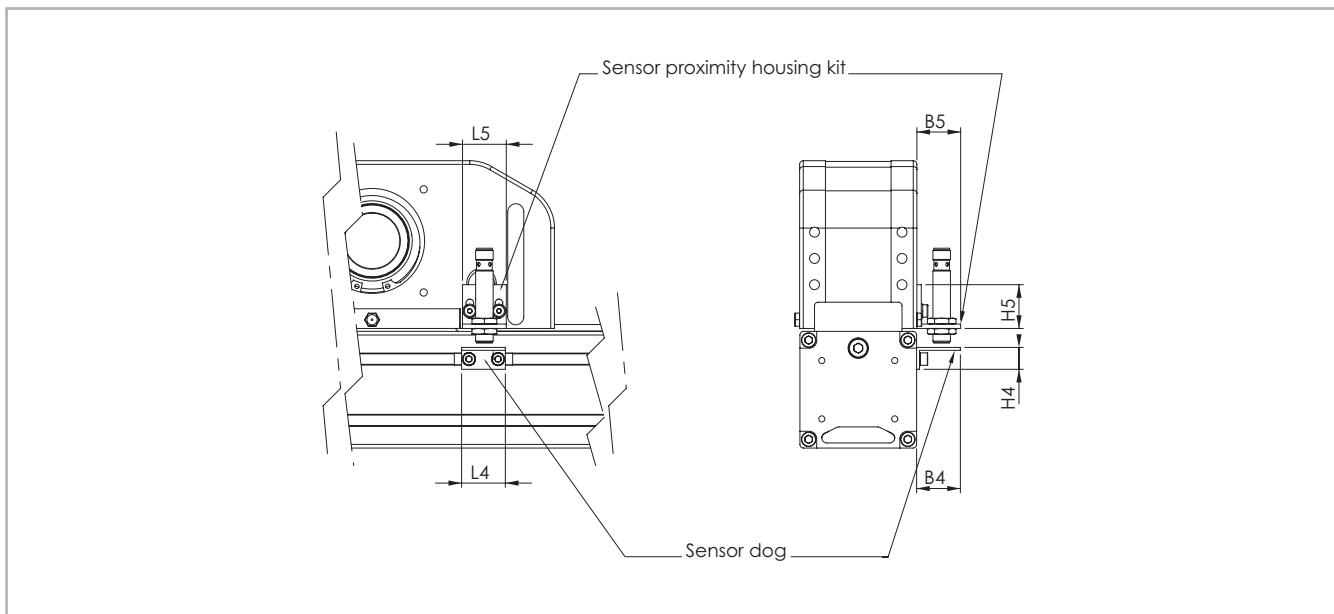

Fig. 45

#### Proximity switch holder

Aluminum block equipped with T-nuts for fixing

#### Proximity switch runner

Iron plate mounted on the carriage used for the proximity operation

### Units (mm)

	B4	B5	L4	L5	H4	H5	For proximity	Sensor dog code	Sensor proximity housing code
S-SMART 50	30	30	30	30	15	30	Ø8 / Ø12	G000835	G000834 / G001408
S-SMART 65	30	30	30	30	15	30	Ø8 / Ø12	G000836	G000834 / G001408
S-SMART 80	30	30	30	30	15	30	Ø8 / Ø12	G000837	G000834 / G001408

Tab. 81

Assembly kits

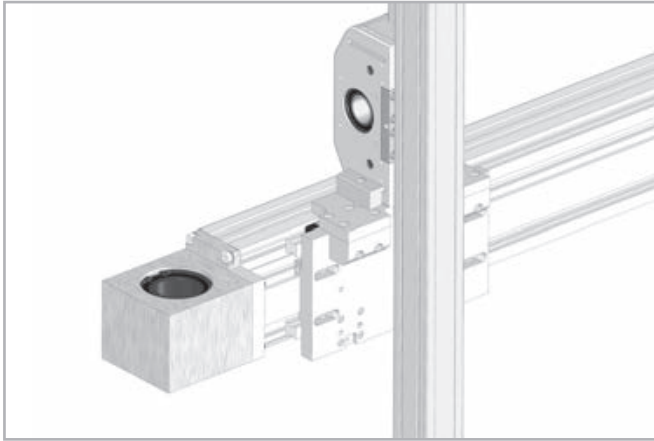

Fig. 46

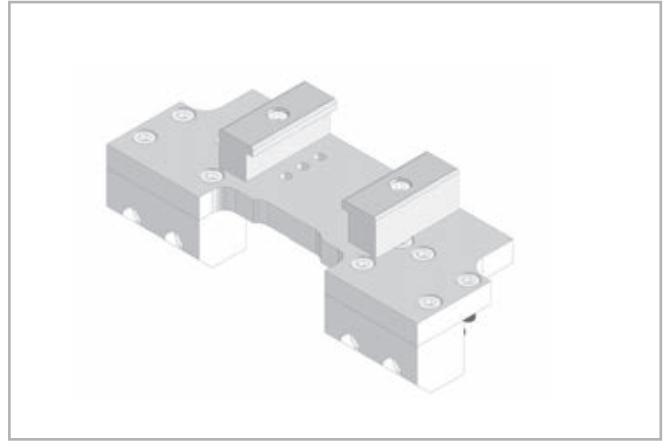











Fig. 47

While ordering two units for Y-Z assembly key has to be specified that they work together in order to drill the trolleys for the assembly of the kit.

Actuator combination Y-Z	Kit Code
 <b>S-SMART 50 on E-SMART 50</b>	G000647
 <b>S-SMART 50 on R-SMART 120</b>	G000910
 <b>S-SMART 65 on E-SMART 50</b>	G000654
 <b>S-SMART 65 on E-SMART 80</b>	G000677
 <b>S-SMART 65 on R-SMART 120</b>	G000911
 <b>S-SMART 65 on R-SMART 160</b>	G000912
 <b>S-SMART 80 on E-SMART 80</b>	G000653
 <b>S-SMART 80 on E-SMART 100</b>	G000688
 <b>S-SMART 80 on R-SMART 120</b>	G000990
 <b>S-SMART 80 on R-SMART 160</b>	G000913

Tab. 82

For examples of S-Smart on E-Smart see page SS-42

Adapter flange for gearbox assembly

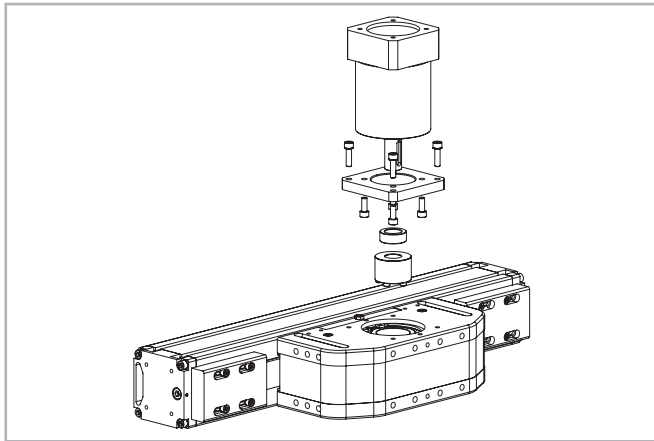

Fig. 48

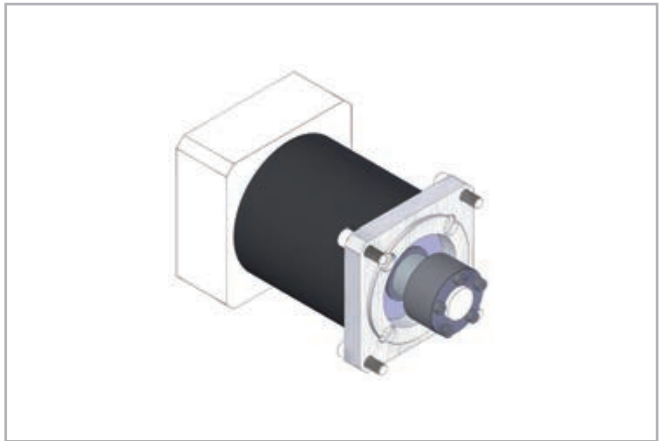

Fig. 49

Assembly kit includes: shrink disk; adapter plate; fixing hardware

Unit	Gearbox type (not included)	Kit Code
S-SMART 50	MP060	G000566
	LC050; PE2; LP050	G001444
S-SMART 65	MP080	G000529
	MP060; PLE060	G000531
	SW030	G000748
	PE3; LP070; LC070	G000530
S-SMART 80	P3	G000824
	MP080	G000826
	LC090; MPV01; LP090; PE4	G000827
	PLE080	G000884
	SP060; PLN070	G000829
	SW040	G000866
	SW050	G000895

Tab. 83

For other gearbox type ask Rollon

# Ordering key

## > Identification codes for the S-SMART linear unit

F	08	2ZA	1300	1A	Linear motion system <i>see pg. SS-32</i>
	05 = 50			1A=SP	
	06 = 65				
	08 = 80				
			L=total length of the unit		
			Drive head code <i>see pg. SS-37</i>		
			Linear unit type <i>see from pg. SS-33 to pg. SS-35</i>		
Linear unit series S-SMART <i>see pg. SS-30</i>					

In order to create identification codes for Actuator Line, you can visit: <http://configureactuator.rollon.com>



### Left / right orientation

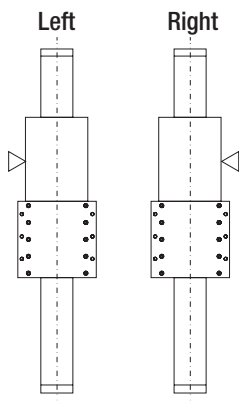

# Multiaxis systems



Previously, customers wishing to build multiaxis units have had to design, draw and manufacture all the elements necessary to assemble two or more axes. Rollon now offers a set of components, including brackets and plates, to enable multiaxis units to be built.

In addition to the standard elements, Rollon can supply plates for special applications.

**Application examples:**

**One axis system**



A

A - X Axis: E-SMART

**Two axis Y-Z system**



C

C - Linear units: Y Axis 2 E-SMART - Z Axis 1 S-SMART

**Connection kit:**

Connection plate Kit for S-SMART (Z axis) on 2 E-SMART (Y axis)

**Two parallel axis system**

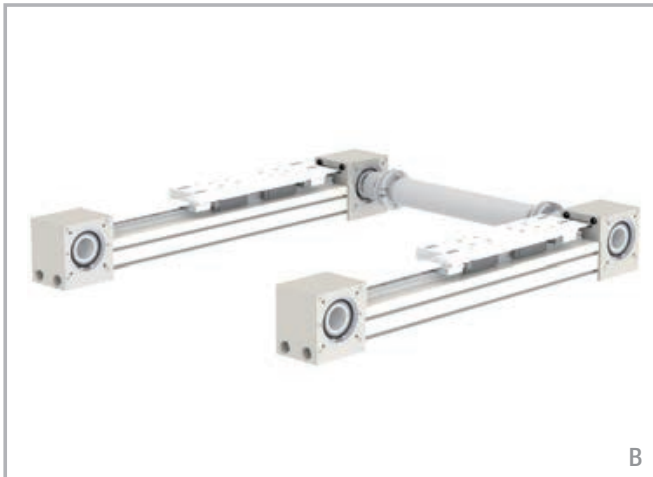

B

B - Linear units: 2 E-SMART

**Connection kit:** Parallel Kit

**Three axis - X-Y-Z system**

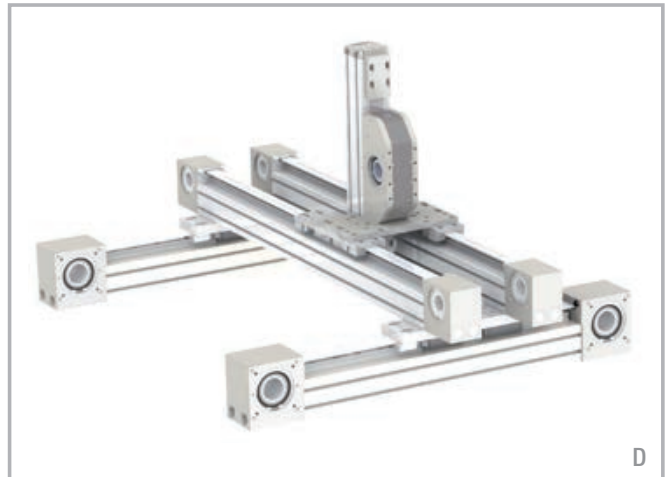

D

D - Linear units: X Axis 2 E-SMART - Y Axis 2 E-SMART - Z Axis 1 S-SMART

**Connection kit:** 2 fixing brackets Kit for 2 E-SMART (X axis) on 2 E-SMART (Y axis). Connection plate Kit for S-SMART (Z axis) on 2 E-SMART (Y axis). Parallel Kit

Two axis Y-Z system



E

**E** - Linear units: Y Axis 1 R-SMART - Z Axis 1 S-SMART  
**Connection kit:** Connection plate Kit for S-SMART (Z axis) on R-SMART (Y axis).

Three axis X-Y-Z system



F

**F** - Linear units: X Axis 2 E-SMART - Y Axis 1 R-SMART - Z Axis 1 S-SMART  
**Connection kit:** 2 fixing brackets Kit for 2 R-SMART (Y axis) on 2 E-SMART (X axis). Connection plate Kit for S-SMART (Z axis) on 2 R-SMART (Y axis). Parallel Kit



# Static load and service life

## > Static load

In the static load test, the radial load rating  $F_y$ , the axial load rating  $F_z$ , and the moments  $M_x$ ,  $M_y$  und  $M_z$  indicate the maximum allowed load values. Higher loads will impair the running characteristics. To check the static load, a safety factor  $S_0$  is used, which accounts for the special conditions of the application defined in more detail in the table below:

All load capacity values refer to the actuator well fixed to a rigid structure. For cantilever applications the deflection of the actuator profile must be taken in account.

### Safety factor $S_0$

No shocks or vibrations, smooth and low-frequency change in direction High mounting accuracy, no elastic deformations, clean environment	2 - 3
Normal assembly conditions	3 - 5
Shocks and vibrations, high-frequency changes in direction, substantial elastic deformations	5 - 7

Fig. 1

The ratio of the actual to the maximum allowed load must not be higher than the reciprocal value of the assumed safety factor  $S_0$ .

$\frac{P_{fy}}{F_y} \leq \frac{1}{S_0}$	$\frac{P_{fz}}{F_z} \leq \frac{1}{S_0}$	$\frac{M_1}{M_x} \leq \frac{1}{S_0}$	$\frac{M_2}{M_y} \leq \frac{1}{S_0}$	$\frac{M_3}{M_z} \leq \frac{1}{S_0}$
---	---	--------------------------------------	--------------------------------------	--------------------------------------

Fig. 2

The above formulae only apply to a one load case. If one or more of the forces described are acting simultaneously, the following calculation must be carried out:

$\frac{P_{fy}}{F_y} + \frac{P_{fz}}{F_z} + \frac{M_1}{M_x} + \frac{M_2}{M_y} + \frac{M_3}{M_z} \leq \frac{1}{S_0}$	$P_{fy}$	= acting load (y direction) (N)
	$F_y$	= static load rating (y direction) (N)
	$P_{fz}$	= acting load (z direction) (N)
	$F_z$	= static load rating (z direction) (N)
	$M_1, M_2, M_3$	= external moments (Nm)
	$M_x, M_y, M_z$	= maximum allowed moments in the different load directions (Nm)

Fig. 3

The safety factor  $S_0$  can be at the lower limit given if the acting forces can be determined with sufficient accuracy. If shocks and vibrations act on the system, the higher value should be selected. In dynamic applications, higher safeties are required. For further information, please contact our Application Engineering Department.

### Belt safety factor referred to the dynamic $F_x$

Impact and vibrations	Speed / acceleration	Orietation	Safety Factor
<b>No impacts and/or vibrations</b>	Low	horizontal	1.4
		vertical	1.8
<b>Light impacts and/or vibrations</b>	Medium	horizontal	1.7
		vertical	2.2
<b>Strong impacts and/or vibrations</b>	High	horizontal	2.2
		vertical	3

Tab. 1



## > Service life

### Calculation of the service life

The dynamic load rating  $C$  is a conventional quantity used for calculating the service life. This load corresponds to a nominal service life of 100 km.

The calculated service life, dynamic load rating and equivalent load are linked by the following formula:

$$L_{km} = 100 \text{ km} \cdot \left( \frac{Fz\text{-dyn}}{P_{eq}} \cdot \frac{1}{f_i} \right)^3$$

$L_{km}$  = theoretical service life (km)  
 $Fz\text{-dyn}$  = dynamic load rating (N)  
 $P_{eq}$  = acting equivalent load (N)  
 $f_i$  = service factor (see tab. 2)

Fig. 4

The effective equivalent load  $P_{eq}$  is the sum of the forces and moments acting simultaneously on a slider. If these different load components are known,  $P$  is obtained from the following equation:

### For SP types

$$P_{eq} = P_{fy} + P_{fz} + \left( \frac{M_1}{M_x} + \frac{M_2}{M_y} + \frac{M_3}{M_z} \right) \cdot F_y$$

Fig. 5

### For CI and CE types

$$P_{eq} = P_{fy} + \left( \frac{P_{fz}}{F_z} + \frac{M_1}{M_x} + \frac{M_2}{M_y} + \frac{M_3}{M_z} \right) \cdot F_y$$

Fig. 6

The external constants are assumed to be constant over time. Short-term loads that do not exceed the maximum load ratings have no relevant effect on the service life and can therefore be neglected in the calculation.

### Service factor $f_i$

$f_i$	
no shocks or vibrations, smooth and low-frequency changes in direction; ( $\alpha < 5\text{m/s}^2$ ) clean operating conditions; low speeds (<1 m/s)	1.5 - 2
Slight vibrations; medium speeds; (1-2 m/s) and medium-high frequency of the changes in direction ( $5\text{m/s}^2 < \alpha < 10\text{m/s}^2$ )	2 - 3
Shocks and vibrations; high speeds (>2 m/s) and high-frequency changes in direction; ( $\alpha > 10\text{m/s}^2$ ) high contamination, very short stroke	> 3

Tab. 2

### Speedy Rail A Lifetime

The rated lifetime for SRA actuators is 80,000 Km.

# Static load and service life Uniline



## > Static load

In the static load test, the radial load rating  $F_y$ , the axial load rating  $F_z$ , and the moments  $M_x$ ,  $M_y$  and  $M_z$  indicate the maximum allowed load values. Higher loads will impair the running characteristics. To check the static load, a safety factor  $S_0$  is used, which accounts for the special conditions of the application defined in more detail in the table below:

### Safety factor $S_0$

No shocks or vibrations, smooth and low-frequency change in direction High mounting accuracy, no elastic deformations, clean environment	1 - 1.5
Normal assembly conditions	1.5 - 2
Shocks and vibrations, high-frequency changes in direction, substantial elastic deformations	2 - 3.5

Fig. 7

The ratio of the actual to the maximum allowed load must not be higher than the reciprocal value of the assumed safety factor  $S_0$ .

$\frac{P_{fy}}{F_y} \leq \frac{1}{S_0}$	$\frac{P_{fz}}{F_z} \leq \frac{1}{S_0}$	$\frac{M_1}{M_x} \leq \frac{1}{S_0}$	$\frac{M_2}{M_y} \leq \frac{1}{S_0}$	$\frac{M_3}{M_z} \leq \frac{1}{S_0}$
---	---	--------------------------------------	--------------------------------------	--------------------------------------

Fig. 8

The above formulae apply to a one load case. If one or more of the forces described are acting simultaneously, the following test must be carried out:

$\frac{P_{fy}}{F_y} + \frac{P_{fz}}{F_z} + \frac{M_1}{M_x} + \frac{M_2}{M_y} + \frac{M_3}{M_z} \leq \frac{1}{S_0}$	<ul style="list-style-type: none"> <li><math>P_{fy}</math> = acting load (y direction) (N)</li> <li><math>F_y</math> = static load rating (y direction) (N)</li> <li><math>P_{fz}</math> = acting load (z direction) (N)</li> <li><math>F_z</math> = static load rating (z direction) (N)</li> <li><math>M_1, M_2, M_3</math> = external moments (Nm)</li> <li><math>M_x, M_y, M_z</math> = maximum allowed moments in the different load directions (Nm)</li> </ul>
--	--

Fig. 9

The safety factor  $S_0$  can be at the lower limit given if the acting forces can be determined with sufficient accuracy. If shocks and vibrations act on the system, the higher value should be selected. In dynamic applications, higher safeties are required. For further information, please contact our Application Engineering Department.

## > Calculation formulae

### Moments $M_y$ and $M_z$ for linear units with long slider plate

The allowed loads for the moments  $M_y$  and  $M_z$  depend on the length of the slider plate. The allowed moments  $M_{zn}$  and  $M_{yn}$  for each slider plate length are calculated by the following formulae:

$$S_n = S_{min} + n \cdot \Delta S$$

$$M_{zn} = \left(1 + \frac{S_n - S_{min}}{K}\right) \cdot M_{zmin}$$

$$M_{yn} = \left(1 + \frac{S_n - S_{min}}{K}\right) \cdot M_{ymin}$$

$M_{zn}$  = allowed moment (Nm)

$M_{zmin}$  = minimum values (Nm)

$M_{yn}$  = allowed moment (Nm)

$M_{ymin}$  = minimum values (Nm)

$S_n$  = length of the slider plate (mm)

$S_{min}$  = minimum length of the slider plate (mm)

$\Delta S$  = factor of the change in slider length

$K$  = constant

Fig. 10

Type	$M_{ymin}$ [Nm]	$M_{zmin}$ [Nm]	$S_{min}$ [mm]	$\Delta S$	$K$
A40L	22	61	240	10	74
A55L	82	239	310		110
A75L	287	852	440		155
C55L	213	39	310		130
C75L	674	116	440		155
E55L	165	239	310		110
E75L	575	852	440		155
ED75L ( $M_z$ )	1174	852	440		155
ED75L ( $M_y$ )	1174	852	440		270

Tab. 3

### Moments $M_y$ and $M_z$ for linear units with two slider plates

The allowed loads for the moments  $M_y$  and  $M_z$  are related to the value of the distance between the centers of the sliders. The allowed moments  $M_{y,n}$  and  $M_{z,n}$  for each distance between the centers of the sliders are calculated by the following formulae:

$L_n = L_{min} + n \cdot \Delta L$ $M_y = \left( \frac{L_n}{L_{min}} \right) \cdot M_{y,min}$ $M_z = \left( \frac{L_n}{L_{min}} \right) \cdot M_{z,min}$	<p><math>M_y</math> = allowed moment (Nm)</p> <p><math>M_z</math> = allowed moment (Nm)</p> <p><math>M_{y,min}</math> = minimum values (Nm)</p> <p><math>M_{z,min}</math> = minimum values (Nm)</p> <p><math>L_n</math> = distance between the centers of the sliders (mm)</p> <p><math>L_{min}</math> = minimum value for the distance between the centers of the sliders (mm)</p> <p><math>\Delta L</math> = factor of the change in slider length</p>
--	--

Fig. 11

Type	$M_{y,min}$ [Nm]	$M_{z,min}$ [Nm]	$L_{min}$ [mm]	$\Delta L$
A40D	70	193	235	5
A55D	225	652	300	5
A75D	771	2288	416	8
C55D	492	90	300	5
C75D	1809	312	416	8
E55D	450	652	300	5
E75D	1543	2288	416	8
ED75D	3619	2288	416	8

Tab. 4

## > Service life

### Calculation of the service life

The dynamic load rating C is a conventional quantity used for calculating the service life. This load corresponds to a nominal service life of 100 km. The corresponding values for each liner unit are listed in Table 45 shown

below. The calculated service life, dynamic load rating and equivalent load are linked by the following formula:

$L_{km} = 100 \text{ km} \cdot \left( \frac{C}{P} \cdot \frac{f_c}{f_i} \cdot f_n \right)^3$	<p><math>L_{km}</math> = theoretical service life (km)</p> <p>C = dynamic load rating (N)</p> <p>P = acting equivalent load (N)</p> <p><math>f_i</math> = service factor (see tab. 5)</p> <p><math>f_c</math> = contact factor (see tab. 6)</p> <p><math>f_n</math> = stroke factor (see fig. 13)</p>
--	---

Fig. 12

The effective equivalent load P is the sum of the forces and moments acting simultaneously on a slider. If these different load components are known, P is obtained from the following equation:

$$P = P_{fy} + \left( \frac{P_{fz}}{F_z} + \frac{M_1}{M_x} + \frac{M_2}{M_y} + \frac{M_3}{M_z} \right) \cdot F_y$$

Fig. 13

The external constants are assumed to be constant over time. Short-term loads that do not exceed the maximum load ratings have no relevant effect on the service life and can therefore be neglected in the calculation.

### Service factor $f_i$

$f_i$	
No shocks or vibrations, smooth and low-frequency changes in direction; clean operating conditions; low speeds (<1 m/s)	1 - 1.5
Slight vibrations; medium speeds; (1-2,5 m/s) and medium-high frequency of the changes in direction	1.5 - 2
Shocks and vibrations; high speeds (>2.5 m/s) and high-frequency changes in direction; high contamination	2 - 3.5

Tab. 5

### Contact factor $f_c$

$f_c$	
Standard slider	1
Long slider	0.8
Double slider	0.8

Tab. 6

### Stroke factor $f_h$

The stroke factor  $f_h$  accounts for the higher stress on the raceways and rollers when short strokes are carried out at the same total run distance. The following diagram shows the corresponding values (for strokes above 1 m,  $f_h$  remains 1):

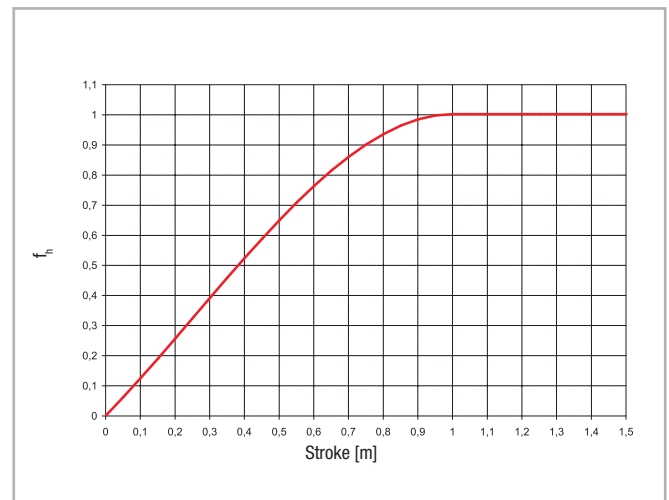

Fig. 14

## > Determination of the motor torque

The torque  $C_m$  required at the drive head of the linear axis is calculated by the following formula:

$$C_m = C_v + \left( F \cdot \frac{D_p}{2} \right)$$

- $C_m$  = torque of the motor (Nm)
- $C_v$  = starting torque (Nm)
- $F$  = force acting on the toothed belt (N)
- $D_p$  = pitch diameter of pulley (m)

Fig. 15

## Warnings and legal notes



Before incorporating the partly completed machinery, we recommend consulting this chapter carefully, in addition to the assembly manual supplied with the individual modules.



The information contained in this chapter and in the manuals for the individual modules, is provided by highly qualified and certified personnel, possessing adequate competence in incorporating the partly completed machinery.



Precaution in installation and handling operations. Significantly heavy equipment.



When handling the axis or system of axes, always make sure that the support or anchoring surfaces do not leave room for bending.



In order to stabilize the axis or system of axes, before handling it is mandatory to securely block the mobile parts. When moving axes with vertical translation (Z AXES) or combination systems (horizontal X and/or more than one vertical Z), it is mandatory to use the vertical movement to put all of the axes at the corresponding lower limit switch.



Do not overload. Do not subject to torsion stress.



Do not leave exposed to atmospheric agents.



Before mounting the motor on the gearbox, it is advisable to perform a pre-test of the motor itself, without connection to the gear unit. The testing of this component was not carried out by the manufacturer of the machine. It will therefore be the responsibility of the customer of Rollon to perform the testing of the same, in order to verify its correct operation.



The manufacturer cannot be considered responsible for any consequences derived from improper use or any use other than the purpose the axis or system of axes was designed for, or derived from failure to comply, during incorporation phases, with the rules of Good Technique and with what is indicated in this manual.



Avoid damage. Do not operate with inadequate tools



Warning: moving parts. Do not leave objects on the axis



Special installations: check the depth of the threads on moving elements



Make sure that the system has been installed on a level floor surface.



In use, accurately comply with the specific performance values declared in the catalog or, in particular cases, the load and dynamic performance characteristics requested in the phase prior to design.



For modules or parts of modular systems with vertical movement (Z axis), it is mandatory to mount self-braking motors to neutralize the risk of the axis dropping.



The images in this manual are to be considered merely an indication and not binding; therefore, the supply received could be different from the images contained in this manual, and Rollon S.p.A has deemed it useful to insert only one example.



Systems supplied by Rollon S.p.A. were not designed/envisaged to operate in ATEX environments.

## > Residual risks

- Mechanical risks due to the presence of moving elements (X, Y axes).
- Risk of fire resulting from the flammability of the belts used on the axes, for temperatures in excess of 250 °C in contact with the flame.
- The risk of the Z axis dropping during handling and installation operations on the partly completed machinery, before commissioning.
- Risk of the Z axis dropping during maintenance operations in the case of a drop in the electrical power supply voltage.
- Crushing hazard near moving parts with divergent and convergent motion.
- Shearing hazard near moving parts with divergent and convergent motion.
- Cutting and abrasion hazards.

## > Basic components



The Partly Completed Machinery shown in this catalog is to be considered a mere supply of simple Cartesian axes and their accessories agreed when the contract is stipulated with the client. The following are therefore to be considered excluded from the contract:

1. Assembly on the client's premises (direct or final)
2. Commissioning on the client's premises (direct or final)
3. Testing on the client's premises (direct or final)

It is therefore understood that the aforementioned operations in points 1., 2., and 3. are not chargeable to Rollon.

Rollon is the supplier of Partly Completed Machinery, the (direct or final) client is responsible for testing and safely checking all equipment which, by definition, cannot be theoretically tested or checked at our facilities where the only movement possible is manual movement (for example: motors or reduction gears, cartesian axes movements that are not manually operated, safety brakes, stopper cylinders, mechanical or induction sensors, decelerators, mechanical limit switches, pneumatic cylinders, etc.). The partly completed machine must not be commissioned until the final machine, in which it is to be incorporated, has been declared compliant, if necessary, with the instructions in Machinery Directive 2006/42/CE.

## > Instructions of an environmental nature

ROLLON operates with respect for the environment, in order to limit environmental impact. The following is a list of some instructions of an environmental nature for correct management of our supplies. Our products are mainly composed of:

Material	Details of the supply
Alluminum alloys	Profiles, pleates, various details
Steel with various composition	Screws, racks and pinions, and rails
Plastic	PA6 – Chains PVC – Covers and sliding block scrapers
Rubber of various types	Plugs, seals
Lubrication of various types	Used for the lubrication of sliding rails and bearings
Rust proof protectione	Rust proof protection oil
Wood, polyethylene, cardboard	Transport packaging

At the end of the product's life cycle, it is therefore possible to recover the various elements, in compliance with current regulations on waste issues.

## > Safety warnings for handling and transport

- The manufacturer has paid the utmost attention to packaging to minimize risks related to shipping, handling and transport.
- Transport can be facilitated by shipping certain components dismantled and appropriately protected and packaged.
- Handling (loading and unloading) must be carried out in compliance with information directly provided on the machine, on the packing and in the user manuals.
- Personnel authorized to lift and handle the machine and its components shall possess acquired and acknowledged skills and experience in the specific sector, besides having full control of the lifting devices used.
- During transport and/or storage, temperature shall remain within the allowed limits to avoid irreversible damage to electric and electronic components.
- Handling and transport must be carried out with vehicles presenting adequate loading capacity, and the machines shall be anchored to the established points indicated on the axes.
- DO NOT attempt to bypass handling methods and the established lifting points in any way.
- During handling and if required by the conditions, make use of one or more assistants to receive adequate warnings.
- If the machine has to be moved with vehicles, ensure that they are adequate for the purpose, and perform loading and unloading without risks for the operator and for people directly involved in the process.
- Before transferring the device onto the vehicle, ensure that both the machine and its components are adequately secured, and that their profile does not exceed the maximum bulk allowed. Place the necessary warning signs, if necessary.
- DO NOT perform handling with an inadequate visual field and when there are obstacles along the route to the final location.
- DO NOT allow people to either transit or linger within the range of action when lifting and handling loads.
- Download the axes just near the established location and store them in an environment protected against atmospheric agents.
- Failure to comply with the information provided might entail risks for the safety and health of people, and can cause economic loss.
- The Installation Manager must have the project to organize and monitor all operative phases.
- The Installation Manager shall ensure that the lifting devices and equipment defined during the contract phase are available.
- The Manager of the established location and the Installation Manager shall implement a “safety plan” in compliance with the legislation in force for the workplace.
- The “safety plan” shall take into account all surrounding work-related activities and the perimeter spaces indicated in the project for the established location.
- Mark and delimit the established location to prevent unauthorized personnel from accessing the installation area.
- The installation site must have adequate environmental conditions (lighting, ventilation, etc.).
- Installation site temperature must be within the maximum and minimum range allowed.
- Ensure that the installation site is protected against atmospheric agents, does not contain corrosive substances and is free of the risk of explosion and/or fire.
- Installation in environments presenting a risk of explosion and/or of fire must ONLY be carried out if the machine has been DECLARED COMPLIANT for such use.
- Check that the established location has been correctly fitted out, as defined during the contract phase and based on indications in the relative project.
- The established location must be fitted out in advance to carry out complete installation in compliance with the defined methods and schedule.

### > Note

- Evaluate in advance whether the machine must interact with other production units, and that integration can be implemented correctly, in compliance with standards and without risks.
- The manager shall assign installation and assembly interventions ONLY to authorized technicians with acknowledged know-how.
- State of the art connections to power sources (electric, pneumatic, etc.) must be ensured, in compliance with relevant regulatory and legislative requirements.
- “State of the art” connection, alignment and leveling are essential to avoid additional interventions and to ensure correct machine function.
- Upon completion of the connections, run a general check to ascertain that all interventions have been correctly carried out and compliance with requirements.
- Failure to comply with the information provided might entail risks for the safety and health of people, and can cause economic loss.



## > Transport

- Transport, also based on the final destination, can be done with different vehicles.
- Perform transport with suitable devices that have adequate loading capacity.
- Ensure that the machine and its components are adequately anchored to the vehicle.

## > Handling and lifting

- Correctly connect the lifting devices to the established points on the packages and/or on the dismantled parts.
- Before handling, read the instructions, especially safety instructions, provided in the installation manual, on the packages and/or on the dismantled parts.
- DO NOT attempt, in any way, to bypass handling methods and the established lifting, moving and handling points of each package and/or dismantled part.
- Slowly lift the package to the minimum necessary height and move it with the utmost caution to avoid dangerous oscillations.
- DO NOT perform handling with an inadequate visual field and when there are obstacles along the route to reach the final location.
- DO NOT allow people to either transit or linger within the range of action when lifting and handling loads.
- Do not stack packages to avoid damaging them, and reduce the risk of sudden and dangerous movements.
- In case of prolonged storage, regularly ensure that there are no variations in the storage conditions of the packages.

## > Check axis integrity after shipment

Every shipment is accompanied by a document ("Packing list") with the list and description of the axes.

- Upon receipt check that the material received corresponds to specifications in the delivery note.
- Check that packaging is perfectly intact and, for shipments without packaging, check that each axis is intact.
- In case of damages or missing parts, contact the manufacturer to define the relevant procedures.

# Data sheet

**General data:** Date: ..... Inquiry N°: .....  
**Address:** ..... **Contact:** .....  
**Company:** ..... **Zip Code:** .....  
**Phone:** ..... **Fax:** .....  
**E-Mail:** .....

**Technical data:**

			X axis	Y axis	Z axis
<b>Useful stroke</b> (Including safety overtravel)	S	[mm]			
<b>Load to be translated</b>	P	[kg]			
<b>Location of Load in the</b>	X-Direction	LxP	[mm]		
	Y-Direction	LyP	[mm]		
	Z-Direction	LzP	[mm]		
<b>Additional force</b>	Direction (+/-)	Fx (Fy, Fz)	[N]		
<b>Position of force</b>	X-Direction	Lx Fx (Fy, Fz)	[mm]		
	Y-Direction	Ly Fx (Fy, Fz)	[mm]		
	Z-Direction	Lz Fx (Fy, Fz)	[mm]		
<b>Assembly position</b> (Horizontal/Vertical/Transversal)					
<b>Max. speed</b>	V	[m/s]			
<b>Max. acceleration</b>	a	[m/s <sup>2</sup> ]			
<b>Positioning repeatability</b>	Δs	[mm]			
<b>Required life</b>	L	yrs			

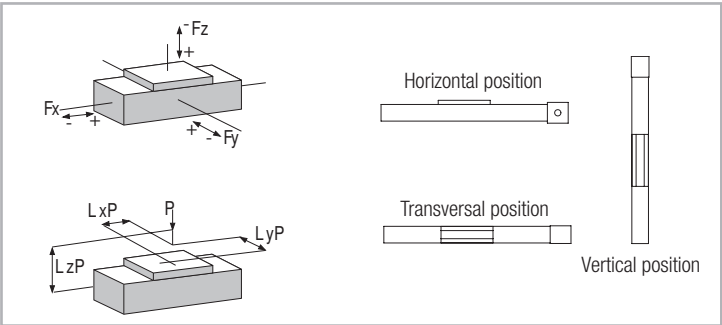

**Attention:** Please enclose drawing, sketches and sheet of the duty cycle



Follow us:



● Rollon Branches & Rep. Offices  
● Distributors

## EUROPE

**ROLLON S.p.A. - ITALY (Headquarters)** ▼

Via Trieste 26  
I-20871 Vimercate (MB)  
Phone: (+39) 039 62 59 1  
www.rollon.it - infocom@rollon.it

**ROLLON GmbH - GERMANY** ▼

Bonner Strasse 317-319  
D-40589 Düsseldorf  
Phone: (+49) 211 95 747 0  
www.rollon.de - info@rollon.de

**ROLLON S.A.R.L. - FRANCE** ▼

Les Jardins d'Eole, 2 allée des Séquoias  
F-69760 Limonest  
Phone: (+33) (0) 4 74 71 93 30  
www.rollon.fr - infocom@rollon.fr

**ROLLON B.V. - NETHERLANDS** ▼

Ringbaan Zuid 8  
6905 DB Zevenaar  
Phone: (+31) 316 581 999  
www.rollon.nl - info@rollon.nl

**ROLLON S.p.A. - RUSSIA (Rep. Office)** ▼

117105, Moscow, Varshavskoye  
shosse 17, building 1  
Phone: +7 (495) 508-10-70  
www.rollon.ru - info@rollon.ru

**ROLLON Ltd - UK (Rep. Office)** ▼

The Works 6 West Street Olney  
Buckinghamshire, United Kingdom, MK46 5 HR  
Phone: +44 (0) 1234964024  
www.rollon.uk.com - info@rollon.uk.com

## AMERICA

**ROLLON Corporation - USA** ▼

101 Bilby Road. Suite B  
Hackettstown, NJ 07840  
Phone: (+1) 973 300 5492  
www.rolloncorp.com - info@rolloncorp.com

**ROLLON - SOUTH AMERICA (Rep. Office)** ▼

R. Joaquim Floriano, 397, 2o. andar  
Itaim Bibi - 04534-011, São Paulo, BRASIL  
Phone: +55 (11) 3198 3645  
www.rollonbrasil.com.br - info@rollonbrasil.com

## ASIA

**ROLLON Ltd - CHINA** ▼

No. 1155 Pang Jin Road,  
China, Suzhou, 215200  
Phone: +86 0512 6392 1625  
www.rollon.cn.com - info@rollon.cn.com

**ROLLON India Pvt. Ltd. - INDIA** ▼

1st floor, Regus Gem Business Centre, 26/1  
Hosur Road, Bommanahalli, Bangalore 560068  
Phone: (+91) 80 67027066  
www.rollonindia.in - info@rollonindia.in

**ROLLON - JAPAN** ▼

3F Shiodome Building, 1-2-20 Kaigan, Minato-ku,  
Tokyo 105-0022 Japan  
Phone +81 3 6721 8487  
www.rollon.jp - info@rollon.jp

Consult the other ranges of products



Distributor

www.linejnye.ru  
e-mail: linejnye@mail.ru  
Тел. +7 (499) 703-15-70  
Москва

All addresses of our global sales partners can also be found at [www.rollon.com](http://www.rollon.com)

The content of this document and its use are subject to the general terms of sale of ROLLON available on the web site [www.rollon.com](http://www.rollon.com)  
Changes and errors expected. The text and images may be used only with our permission.