

ROLLON[®]
BY TIMKEN

Speedy Rail

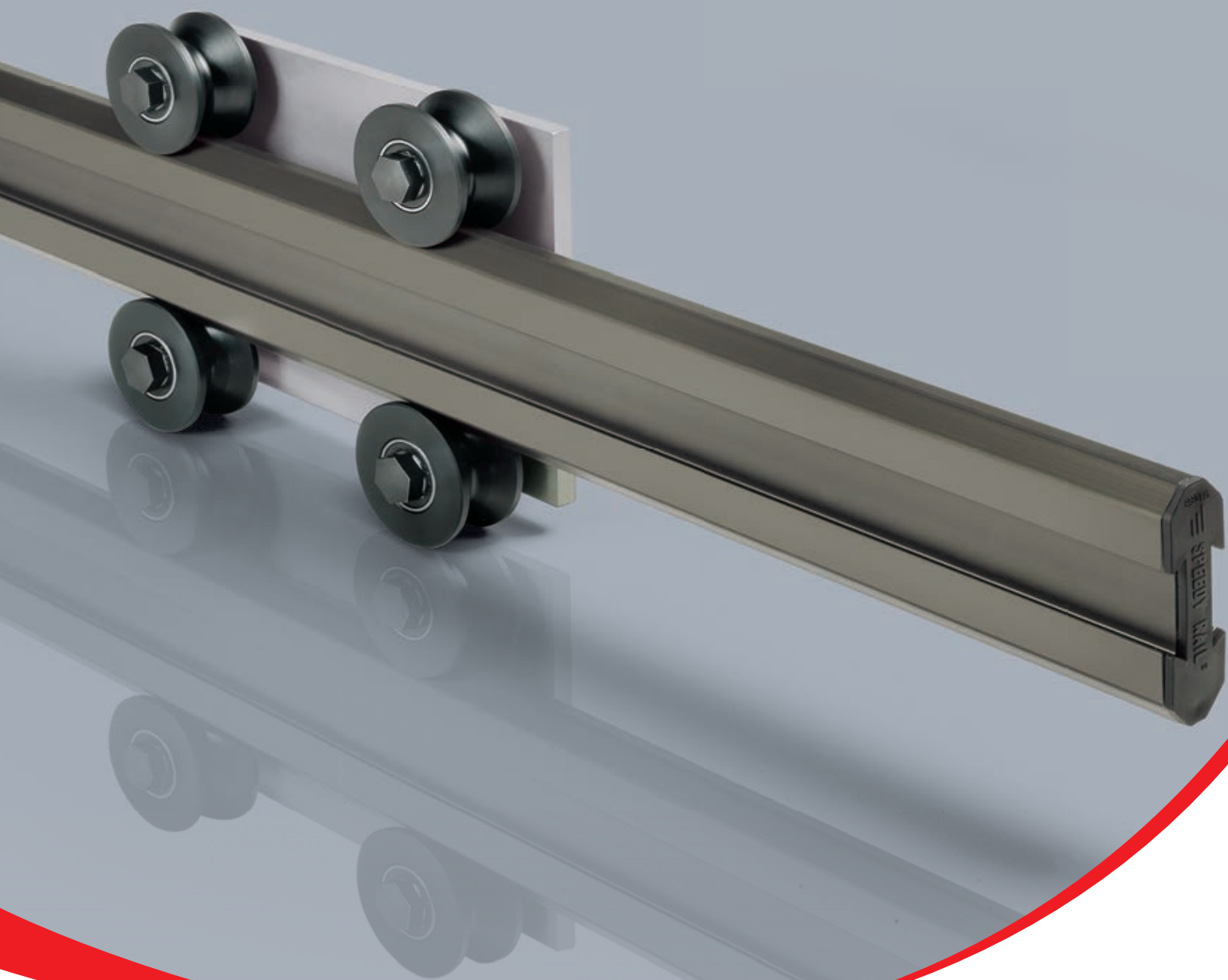

We design and produce in order to support you

*An international group
for technology,
a local support for service*

*Over 40 years of know how
in design and production*

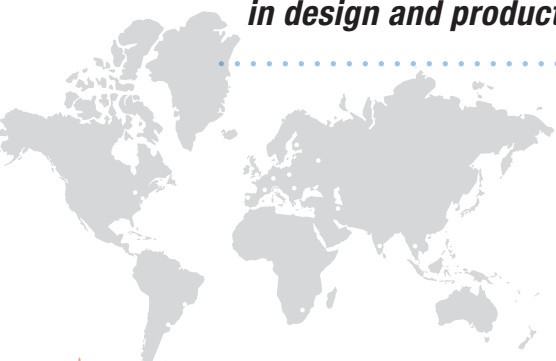

Values

Applications

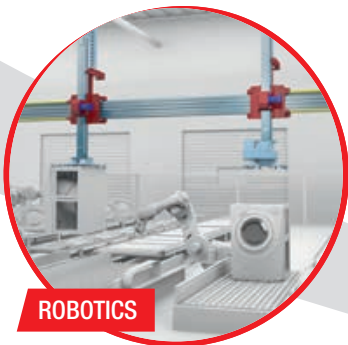

ROBOTICS

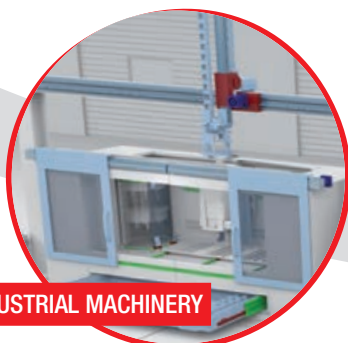

INDUSTRIAL MACHINERY

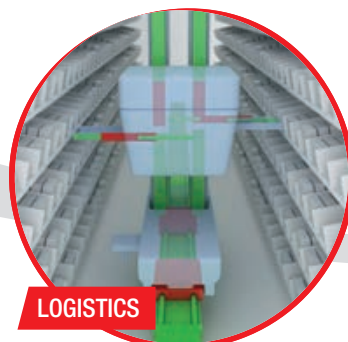

LOGISTICS



RAILWAY

Collaboration

High level technical consulting

Cross competences in several industrial sectors for an effective problem-solving

Solutions

From a full range of standard products to fit-to-customer solutions for best performances

AERONAUTICS

SPECIAL VEHICLES

MEDICAL

INTERIORS AND ARCHITECTURE

A complete range for linear motion which reaches every customer



Linear and curved guides with ball and roller bearings, with hardened raceways, high load capacities, self-alignment and capable of working in dirty environments.

Linear Line



Telescopic Line

Telescopic guides with ball bearings, with hardened raceways, high load capacities, and low bending, resistant to shocks and vibrations. For partial, total or extended extraction up to 200% of the length of the guide.



Actuator Line

Linear actuators with different guide configurations and drives, available with belt, screw or rack and pinion drives according to different needs in terms of precision and speed. Guides with bearings or ball recirculating systems for different load capacities and critical environments.

*A global provider
of solutions
for applications
for linear motion*



Actuator System Line

Integrated actuators for industrial automation, they find applications in numerous industrial sectors: from machinery servo systems to high precision assembly systems, packaging lines and high speed production lines. It has evolved from Actuator Line series in order to meet the most demanding needs of our customers.

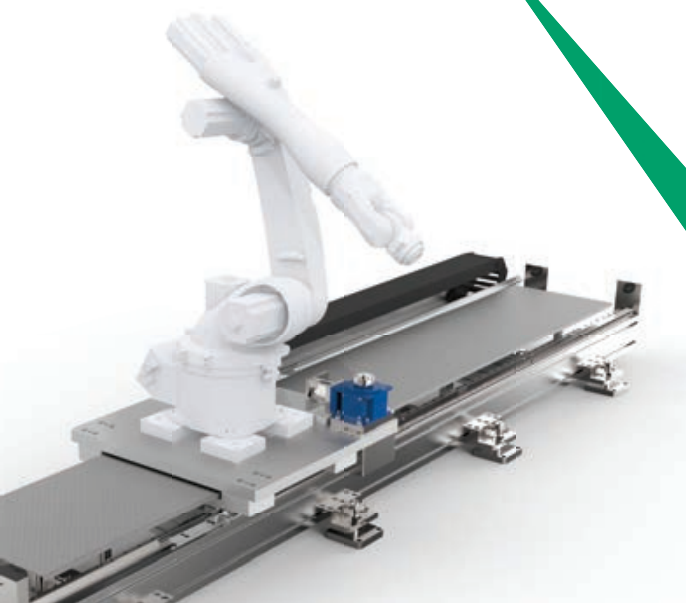

> Speedy Rail



1 Introduction

The product, Features and user benefits	SR-2
Application fields	SR-3
Dimensions, Rollers and roller assemblies	SR-4
Measurement units	SR-5

2 Speedy Rail 35

"Speedy Rail 35" guide and specification	SR-6
"Speedy Rail 35" assemblies and components	SR-7
Sliding doors "Speedy Rail 35" application example	SR-9

3 Speedy Rail C 48

"Speedy Rail C 48" guide and specification	SR-10
"Speedy Rail C 48" assemblies and components	SR-11
Rollers and roller boxes for "Speedy Rail C 48" guide	SR-12
Roller boxes for "Speedy Rail C 48" guide	SR-13

4 Speedy Rail 60

"Speedy Rail Mini" guide and specification	SR-14
"Speedy Rail Mini" roller assemblies and components	SR-15
"Speedy Rail Mini" guide and components	SR-16
Dovetail clamps and fishplates	SR-17
Roller assembly and "V" rollers "Light"	SR-18
Roller assemblies and "V" rollers	SR-19

5 Speedy Rail 90

"Middle Speedy Rail" guide and specifications	SR-21
"Middle Speedy Rail" assemblies and components	SR-22
"Middle Speedy Rail" guide and components	SR-23
Dovetail clamps and fishplates	SR-24
Plastic compound shell "V" rollers	SR-25
Roller assembly with "V" shaped rollers	SR-26

6 Speedy Rail 120

"Standard Speedy Rail" guide and specifications	SR-27
"Standard Speedy Rail" assemblies and components	SR-28
"Standard Speedy Rail" guide and specifications	SR-29
Components for speedy rail SR120 guide	SR-30
Standard dovetail clamps	SR-31
Racks components for rigid mounting	SR-32
Standard fixing fishplates	SR-33
Plastic compound shell "V" rollers	SR-34
Roller assembly with "V" rollers	SR-35
Plastic compound shell rollers	SR-36
2 Rollers light full-block assembly	SR-38
Compact roller assembly with plastic compound rollers	SR-39
Full-block roller assembly	SR-40
Roller assembly with 4 rollers	SR-41
Narrow/wide base blindo beam roller assembly	SR-42
8 Rollers blindo beam roller assembly	SR-43
Light 4 rollers floating assembly for Speedy Rail guides	SR-44
Floating roller assembly with 4 rollers - short/long pivot	SR-45
5 Rollers assembly, one fixed, one self adjusting	SR-46
Floating roller assembly with 6 rollers - short/long pivot	SR-47
Floating roller assembly with 8 rollers - short/long pivot	SR-49

Assembling diagram for rigid mounted rack	SR-50
Standard racks	SR-51
Standard scrapers	SR-52
7 Speedy Rail 180	
Wide body multi groove speedy rail guide and specifications	SR-53
Roller assemblies and components	SR-54
Wide body multi groove speedy rail guide and specifications	SR-55
Components for wide body multi groove Speedy Rail guide	SR-56
Roller assembly with "V" shaped rollers	SR-57
Roller assembly with 4 rollers	SR-58
8 Rollers floating assembly - complete pairing	SR-59
Backing plate for floating roller assemblies	SR-60
8 Speedy Rail 250	
Super wide body multi groove speedy rail guide and specifications	SR-61
Roller assemblies and components	SR-62
Superwide body multi groove speedy rail guide and specifications	SR-63
Components for super wide body speedy rail guide	SR-64
Roller assembly with "V" shaped rollers	SR-65
9 Technical detail	
Mechanical and technological components specifications	SR-66
Treatments on all light alloy components, Rollers, Roller assemblies	SR-67
Rollers adjustments, Torque settings, Scrapers, Drive head	SR-68
Lubrication, Life testing	SR-69
Summary table Speedy Rail guides	SR-70
Loads on a 4 'V' rollers trolley	SR-71
Loads on twin 4 'V' rollers trolleys	SR-75
Loads on a 4 'V' rollers vertical trolley	SR-76
Cilindrical roller loads	SR-77
User suggestions	SR-79
10 Applications	SR-82
11 Generail index	SR-87

Introduction



> The product:

Speedy Rail® beam is a heat-treated aluminium alloy profile with hollow cross-sections which makes it very strong under torsion and deflection stresses.

Beams are then subject to a special patented treatment which provides a smooth, hard (700 HV) surface comparable to tempered steel. The fusion point of the non-stick surface layer (2100°C) permits an excellent resistance to welding splatters.

For these reasons the **Speedy Rail**® beams and components are widely used in the automotive industry to build transfer systems (lift & carry) for automated welding lines.

Many quantities of car bodies during the welding operations are moved by **Speedy Rail**® linear systems.

One of the most successfully feature of Rollon lines is that it is practically “maintenance free”.

> Features and user benefits:

- Wide range of linear transport applications
- Standard modular components
- All parts reusable
- Minimum space required
- Narrow profile
- Hard surface
- Resistance to welding splatters
- Quiet smooth operations
- Resistance to high corrosion
- Easy to assemble
- Saving in assembly time
- Strong, lightweight
- Savings in reducing drive size
- Only hand tools required to assemble or modify

Speedy Rail® linear motion systems are lightweight, self-supporting, easy to assemble, inexpensive, modular, clean, quiet and ex stock. **Speedy Rail**® assemblies are very simple. Standard bolted dovetails and fishplate clamps are used for end to end joining. Rails are available in single beam up to max length 7.5 meters – 24.6 feet – and can be joined end-to-end with dovetails to build a transfer system of unlimited length. Rails have a dovetail groove on each side to accommodate any fixture. In this way it is not necessary to drill or to weld.

The profiles Wide Body SR 180, Super Wide Body SR 250 are equipped with grooves and have a planarity precision so that guideways can be fixed without any mechanical machining.

> Application fields:

- Automotive assembly
- Woodworking and furniture
- Glass processing
- Tire industry
- Painting lines
- Food industry
- Sheet working and laser cut machines
- Plastic extrusion, machine tools
- Appliances assembly and production
- Electronics
- Print, slitter machines
- Cardboard handling machines
- Industrial cleaning
- Packaging
- Tiles, shingles production
- Sportive equipment
- Welding lines
- Overhead transfers and panels handling
- Overhead pick-up and transfer, packaging
- Line of 6/10 stations for tire production
- Multi axis for paint-gun movement
- Cartesian water cutting systems, packaging
- Feeding and scavenging systems
- Rails for protections, tool change system
- Frame and body welding
- Card transfer and dip-in chemical solution tray
- Palletizing, print head replacement
- Palletizers
- Overhead lines with pick-up and transfer
- Palletizers, shrink-wrap machines
- Production transfers
- Guides for target in the shooting, linear sliding for athletic equipment
- Textiles, pharmaceuticals, steel coil processing, etc.
- And more

> Dimensions

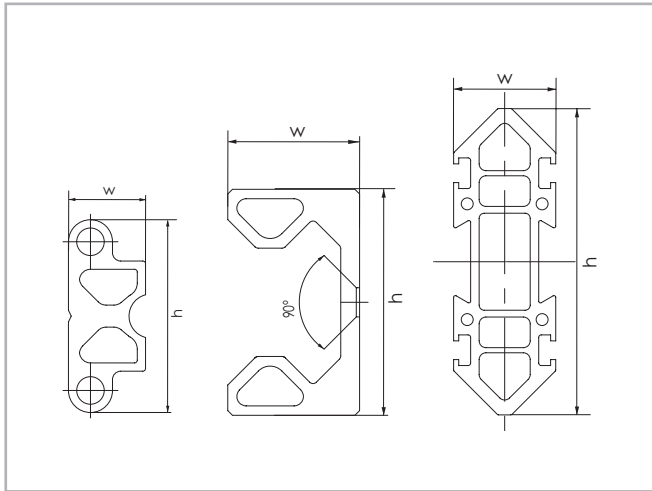

Fig. 1

Speedy Rail® guides are available in the following sizes:

Type	h [mm]	w [mm]
Speedy Rail 35	35	14
Speedy Rail C 48	48	28
Speedy Rail Mini	60	20
Speedy Rail Middle	90	30
Speedy Rail Standard	120	40
Speedy Rail Wide Body	180	60
Speedy Rail Super Wide Body	250	80

Tab. 1

> Rollers and roller assemblies:

The **Speedy Rail®** range includes a large selection of rollers both cylindrical and “V” shaped and roller assemblies with two or more rollers. Our rollers are covered by a sintered plastic compound, resistant to pollutants and virtually maintenance-free. Ball and/or needle bearings with high performance are mounted into the rollers and can be maintained either with standard greasing procedure or lifetime lubricated. All roller boxes are equipped with concentric and eccentric pins for a quick adjustment of the contact between rollers and rail.

- Standard
with 2 rollers, 1 concentric and 1 eccentric
- Blindo Beam®
with 4 or 8 rollers. It provides 3 mounting surfaces
- Compact
with 2 rollers. Suitable for low clearances and limited operation room
- Floating
with 4, 6 or even more rollers. Suitable for the withstanding minor misalignments on the rail mounted in pairs, one concentric and one eccentric
- “V” roller support
This kind of support are suggested for light applications and constricted operation areas

Supports are mounted on the frame when the rail is movable and on the trolleys when it is fixed. By the calculation of system needs, consider the max. radial load applicable to the rollers in accordance with the description of each roller.

> Measurement units

Conversion tables

	English to metric			Metric to english		
	Unit	Symbol	Value	Unit	Symbol	Value
Length unit	inch	in	25.4 mm	millimeter	mm	0.039 in
	foot	ft	0.3 m	meter	m	3.3 ft
	yard	yd	0.91 m	meter	m	1.1 yd
	mile	mi	1.6 Km	kilometer	km	0.6 ml
Surface unit	square inch	in ²	6.5 cm ²	square centimeter	cm ²	0.16 in ²
	square foot	ft ²	929 cm ²	square meter	m ²	11 ft ²
	square yard	yd ²	0.83 m ²	square meter	m ²	1.2 yd ²
Volume unit	cubic inch	in ³	16.4 cm ³	cubic centimeter	cm ³	0.06 in ³
	cubic foot	ft ³	0.027 m ³	cubic meter	m ³	35 ft ³
	cubic yard	yd ³	0.765 m ³	cubic meter	m ³	1.3 yd ³
Capacity unit	US gallon	gal usa	3.78 l	litre	l	0.264 gal usa
	Imperial gallon	gal uk	4.54 l	litre	l	0.220 gal uk
Mass unit	ounce	oz	28.35 g	gram	g	0.035 oz
	pound	lb	0.453 kg	kilogram	kg	2.204 lb
Power unit	horse power uk	bhp	0.745 kW	kilowatt	kW	1.341 bhp
	foot-pound	lbf ft/s	745 W	Watt	lbf ft/s	745 W
	horse power uk	bhp	1.01 CV	horse power	CV	0.986 bhp
Speed unit	foot per second	ft/s	0.305 m/s	meter per second	m/s	3.278 ft/s
Force unit	pound-force	lbf	4.448 N	Newton	N	0.224 lbf
Mechanical moment unit	inch-pound	lbf in	0.112 Nm	Newton-meter	Nm	8.856 lbf in
	foot-pound	lbf ft	1.355 Nm	Newton-meter	Nm	0.738 lbf ft
Pressure unit	pound-force/square inch	psi	6894.7 Pa	Pascal	Pa	0.00015 psi
Lineic weight unit	pound per foot	lb/ft	14.593 N/m	Newton per meter	N/m	0.0685 lb/ft
Frequency unit	cycles per second	cps	1 Hz	Hertz	Hz	1 cps
Energy unit	British thermal unit	Btu	1055.06 J	Joule	J	0.00094 Btu
	foot-pound	lbf ft	1.355 J	Joule	J	0.738 lbf ft

Tab. 2

Thermodynamic scales

Description	Symbol	tC	tF	tK
temp. Celsius	tC	1	5/9 (tF-32)	tK-273.15
temp. Fahrenheit	tF	9/5 tC+32	1	9/5 tK-459.67
temp. Kelvin	tK	tC+273.15	5/9 tF+255.37	1

Tab. 3

Speedy Rail 35



> "Speedy Rail 35" guide and specification

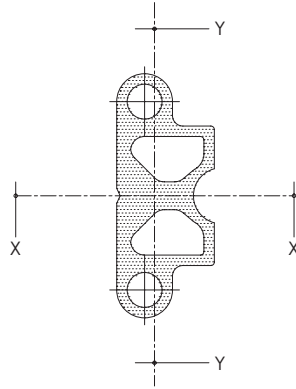

Fig. 2

Surface quadratic moments: X-X axis = 17.779 mm⁴ / Y-Y AXIS = 3.665 mm⁴.

Area = 222 mm²

Max. angular distorsion = $\pm 20'$ /m.

Linear mass = 0.55 Kg/m.

Max. Linear distorsion = 0.5 mm/m.

Standard lengths: 1000-1500-2000-2500-3000-3500-4000-4500 mm.

External surface: deep hard anodizing

> "Speedy Rail 35" assemblies and components

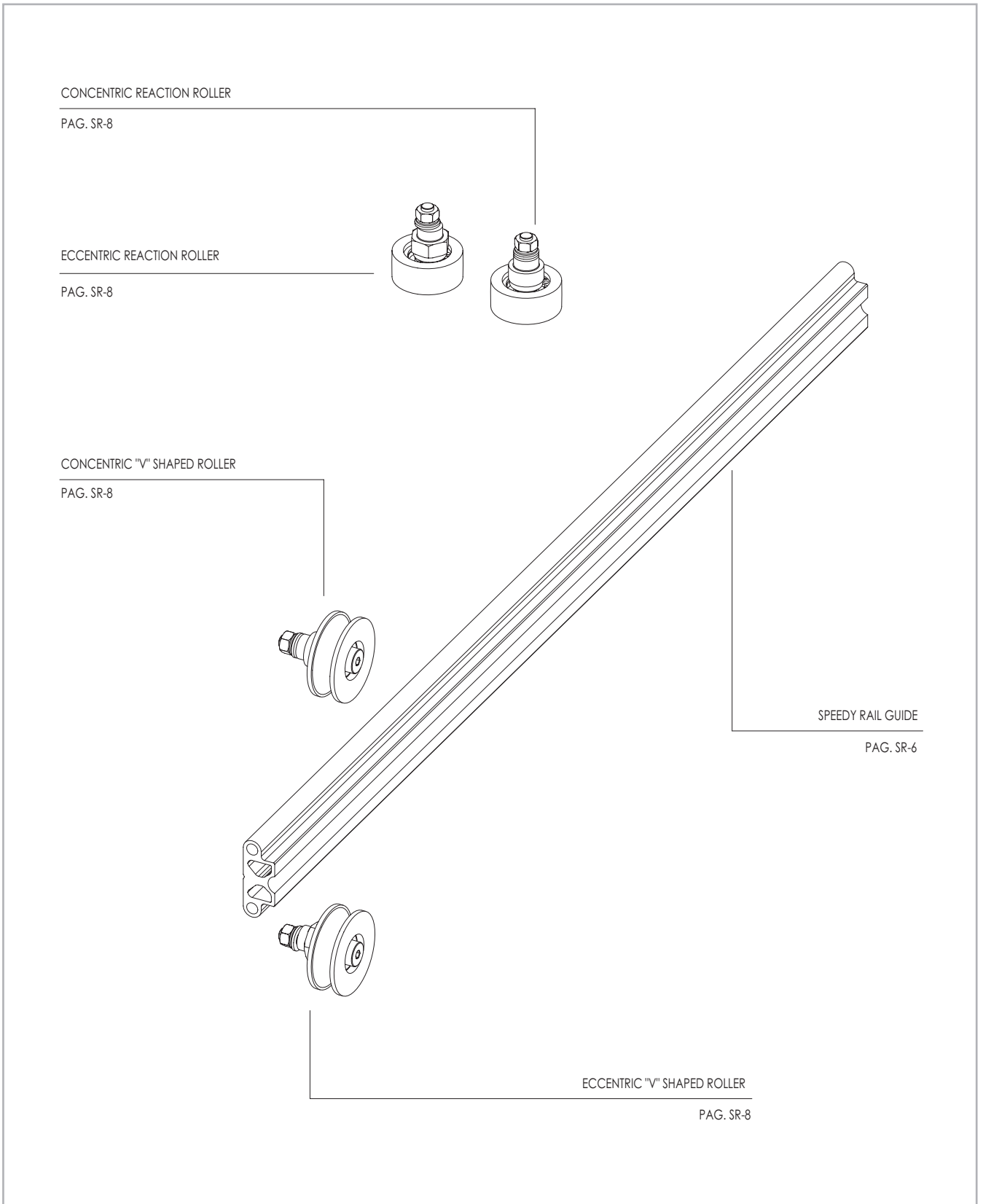

Fig. 3

S
R

Speedy Rail guide with plain ends

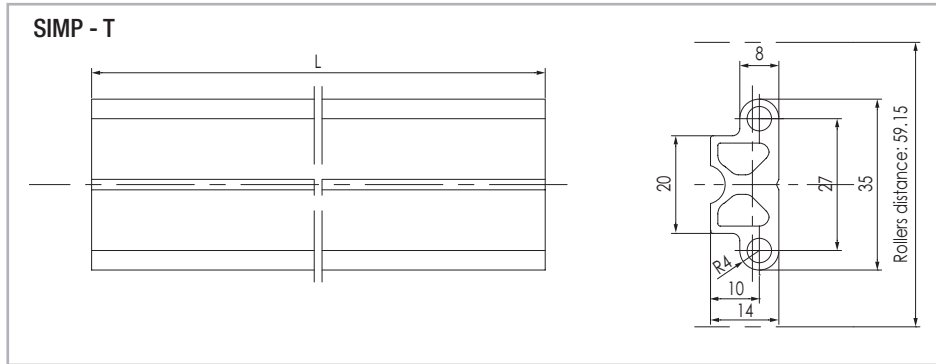

Fig. 4

Drilled Speedy Rail 35 guide - Order code 411.1405/length in mm.

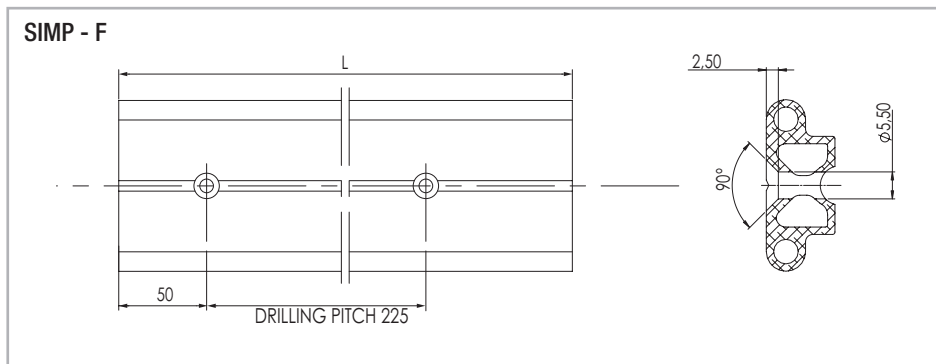

Fig. 5

Plastic compound eccentric roller,
max load: radial 200 N, axial 100 N

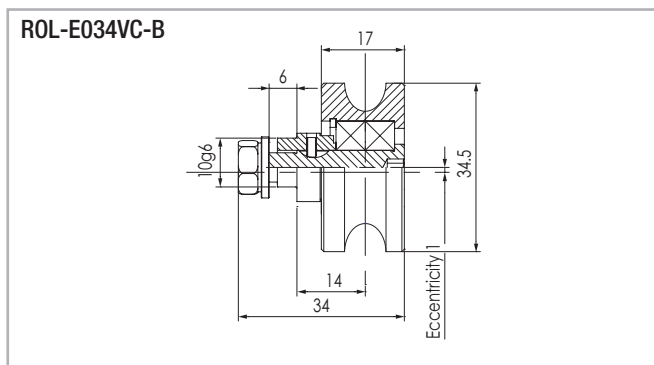

Fig. 6

Plastic compound concentric roller,
max load: radial 200 N axial 100 N

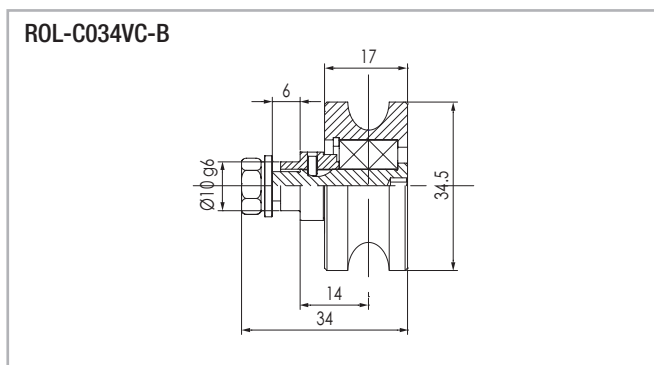

Fig. 7

Plastic compound concentric contrast roller,
max radial load 200 N

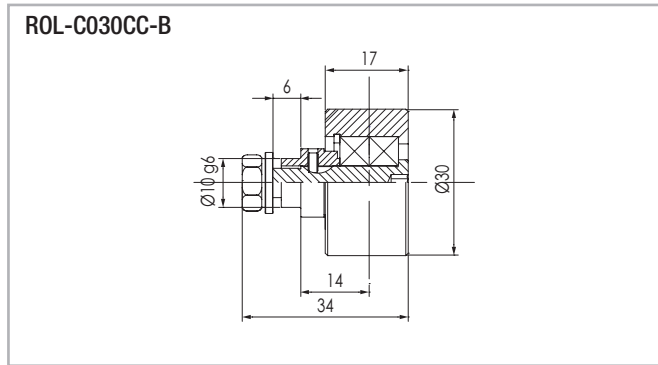

Fig. 8

Plastic compound eccentric contrast roller,
max radial load 200 N

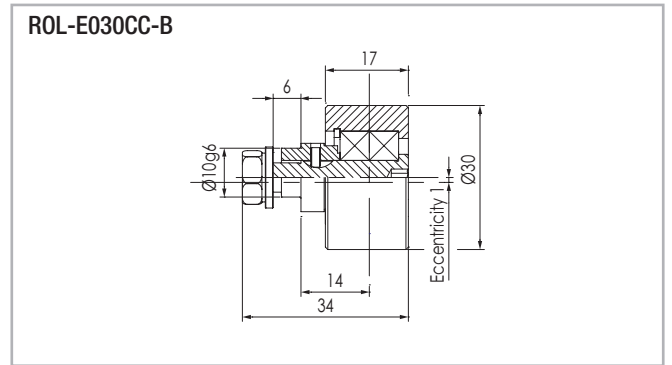

Fig. 9

> Sliding doors "Speedy Rail 35" application example

Overturning locking upper rollers
Supporting lower rollers

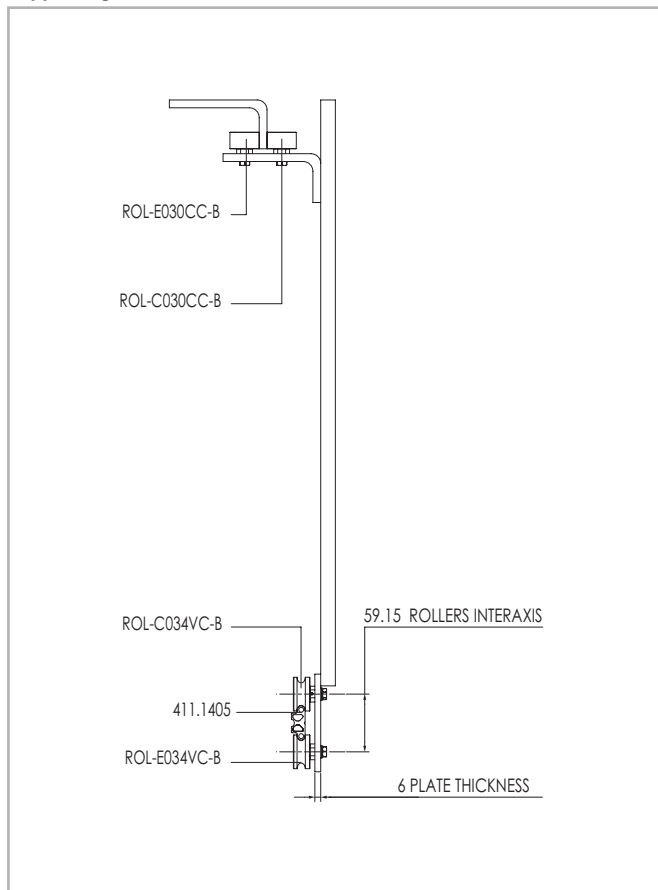

Fig. 10

Speedy Rail C 48



> "Speedy Rail C 48" guide and specification

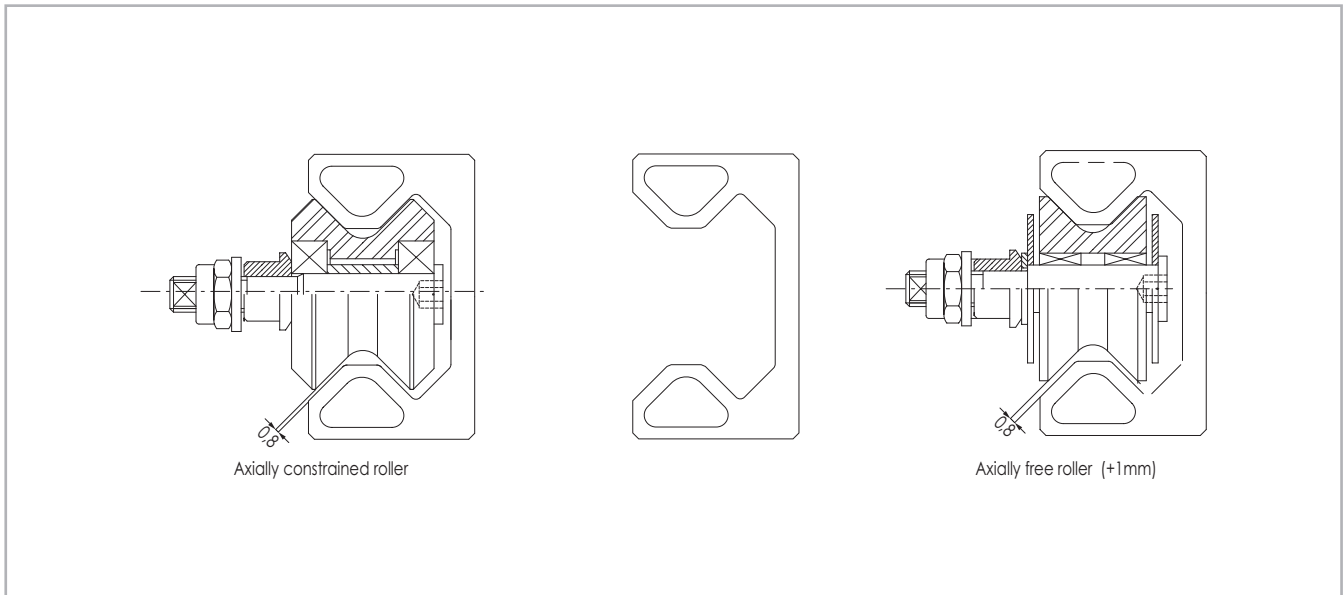

Fig. 11

"Speedy Rail C 48" guide

Material: aluminium alloy with hardened surface (700 Hv)

Surface quadratic moments: "I" XX AXIS= 152.026 mm⁴ "I" YY AXIS= 36.823 mm⁴

Section modules: W (X) = 6334 mm³ / W (Y) = 2045 mm³

Distance between the centre line of opposite rolling lanes: 28,86 mm

Linear mass = 1,42 kg/m.

Max. Angular distorsion = ±20' / m max.

Max. linear distorsion = ±0,4 mm/m. Max.

Standard lengths: 500-1000-1500-2000-2500-3000-3500-4000-4500-5000-5500-6000-6500-7000-7500 mm.

Exterior treatment: deep hard anodizing

Rollers

Supported by ball or needle bearings. The external surface is finished with plastic compound

Speedy Rail C 48 guide without holes

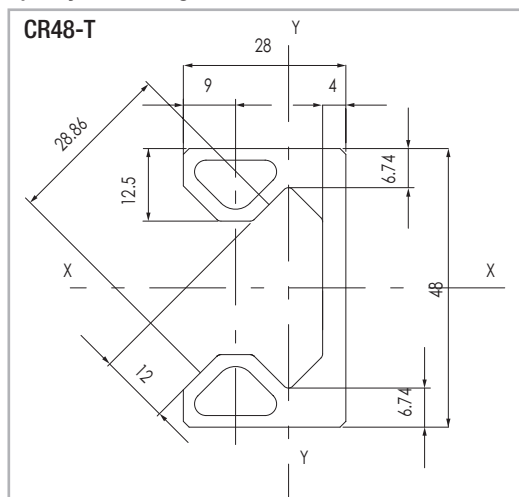

SR-10

Fig. 12

Drilled Speedy Rail C 48 with holes for front fixing

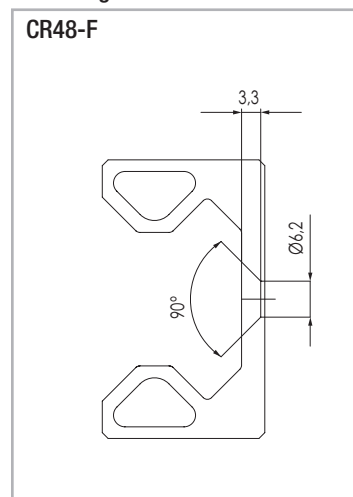

Fig. 13

Drilled Speedy Rail C 48 with holes for rear fixing

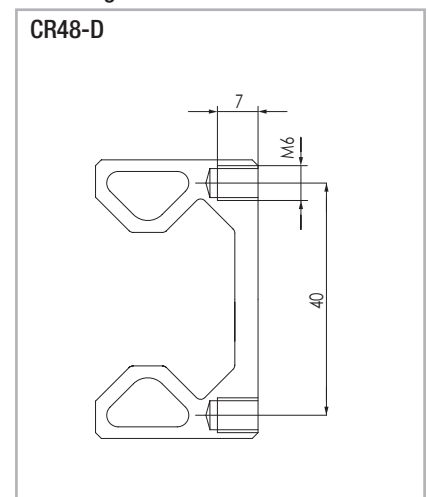

Fig. 14

> "Speedy Rail C 48" assemblies and components

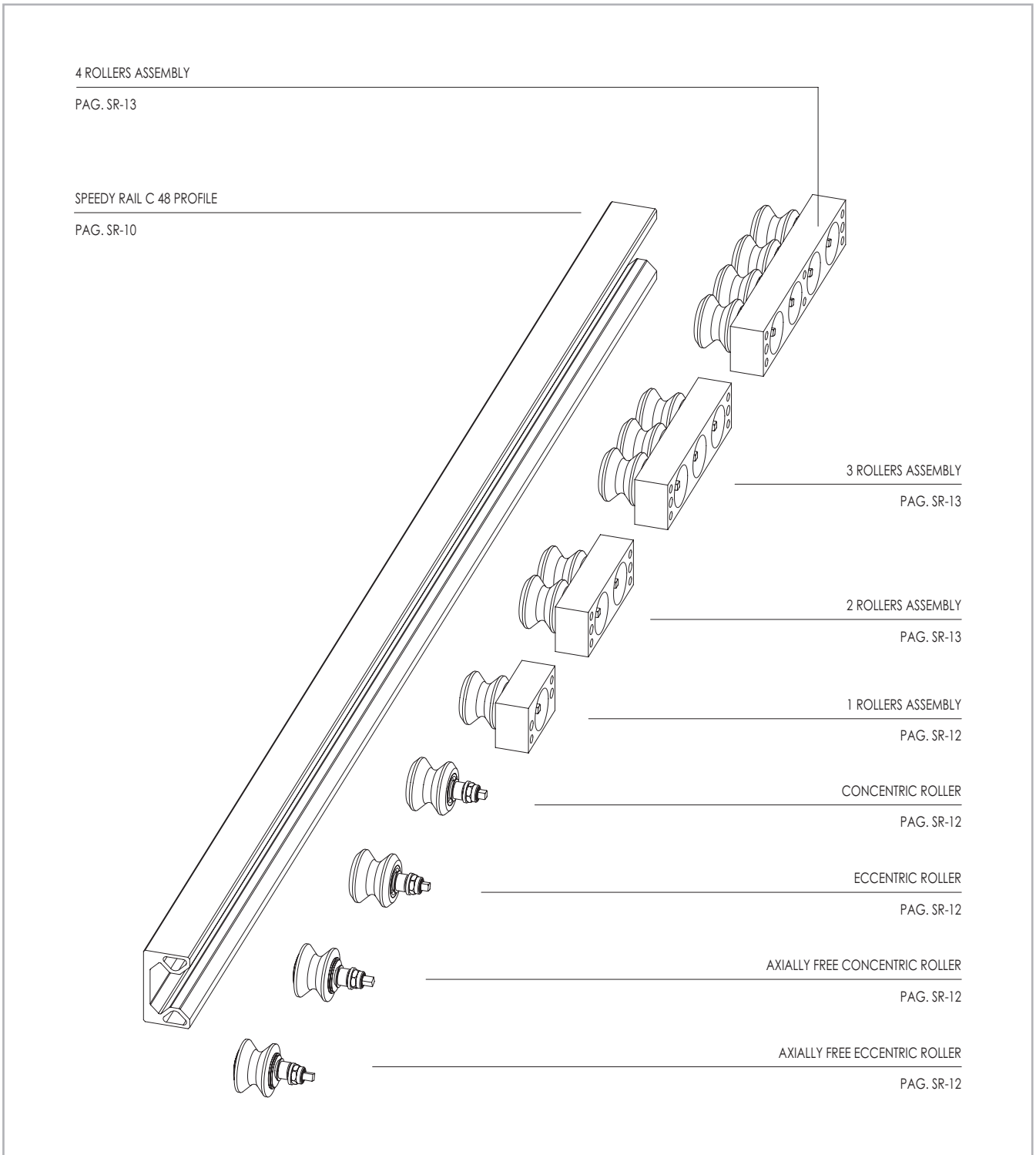

Fig. 15

> Rollers and roller boxes for "Speedy Rail C 48" guide

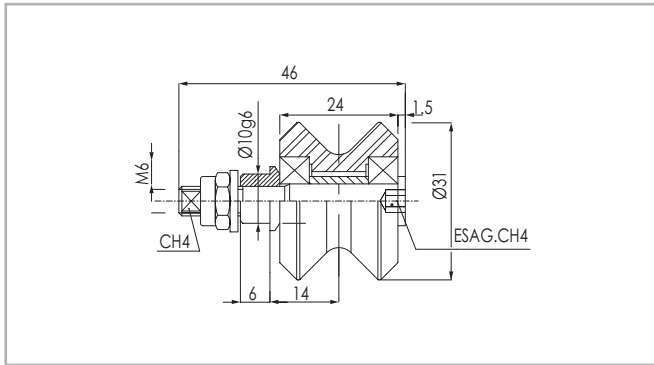

Fig. 16

ROL-C031WC-X - Axially constrained concentric roller
 ROL-E031WC-B - Axially constrained eccentric roller (ecc. max. 1.4 mm)
 Max radial load 270 N - max axial load 100 N

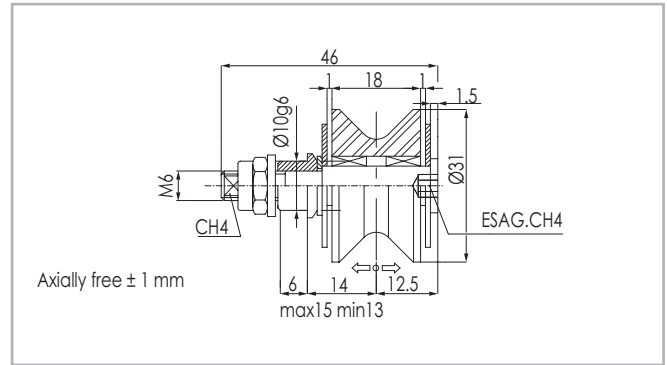

Fig. 17

ROL-C031VC-XA - Axially free concentric roller
 ROL-E031VC-BA - Axially free eccentric roller (ecc. max. 1.4 mm)
 Max radial load 270 N - it doesn't accept axial load

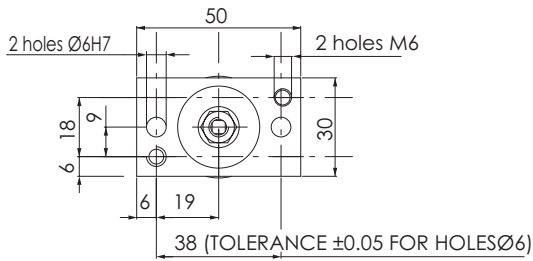

Fig. 18

55.1062 - Roller assembly with one conc. roller
 55.1067 - Roller assembly with one ecc. roller
 Max. Load per roller: radial 270 N / axial 100 N

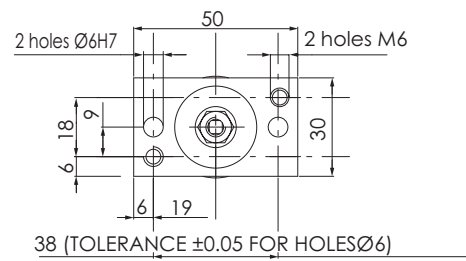

Fig. 19

55.1066 - Roller assembly with one conc. axial free roller
 55.1065 - Roller assembly with one ecc. axial free roller
 Max. Load per roller: radial 270 N
 No axial loading

> Roller boxes for "Speedy Rail C 48" guide

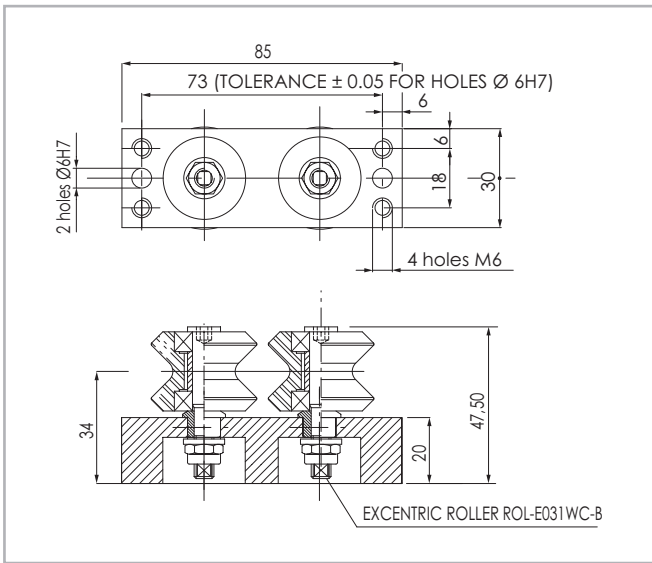

Fig. 20

55.1061 - Roller assembly with one concentric and one excentric roller
 Max. load per roller: radial 270 N / axial 100 N

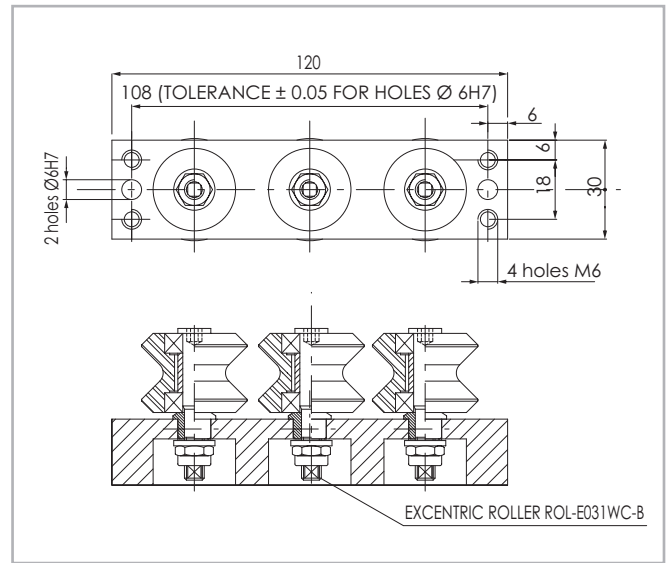

Fig. 21

55.1060 - Roller assembly with two concentric rollers and one excentric roller
 Max. load per roller: radial 270 N / axial 100 N

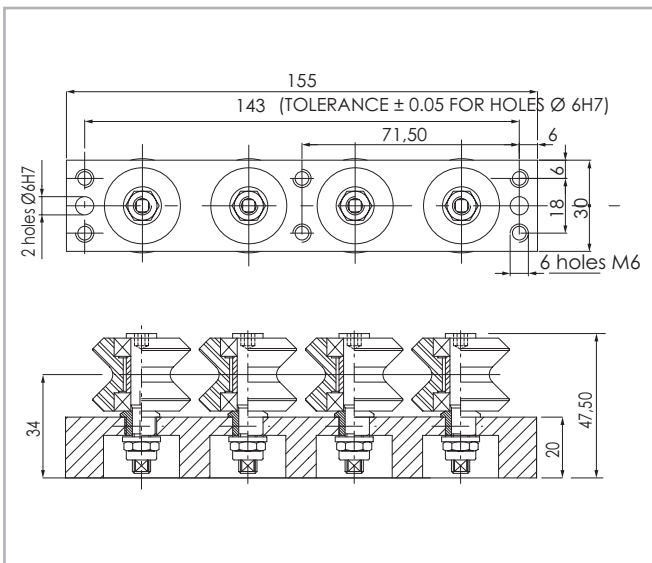

Fig. 22

55.1064 - Roller assembly with 4 rollers, 3 conc. and 1 ecc.
 Max. load per roller: radial 270 N / axial 100 N

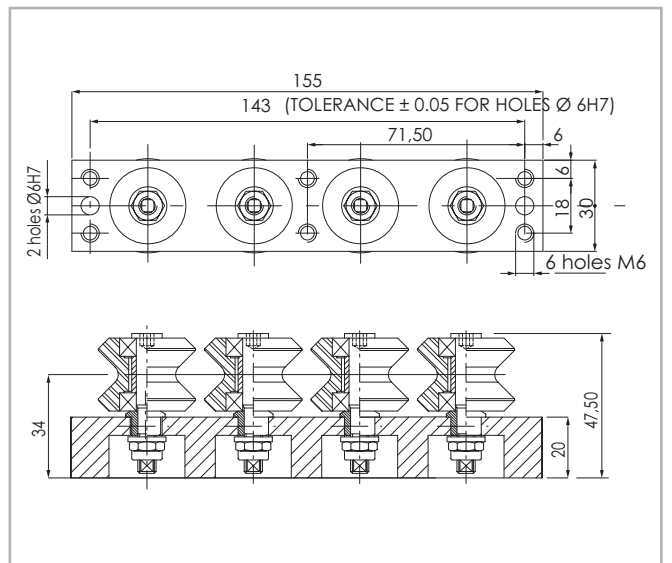

Fig. 23

55.1069 - Roller assembly with 4 rollers, 2 conc. and 2 ecc.
 Max. load per roller: radial 270 N / axial 100 N

On roller assemblies with 2-3-4 rollers it is possible to have different solutions (axial constrained, axial free, concentric and eccentric rollers).

Speedy Rail 60



> "Speedy Rail Mini" guide and specification

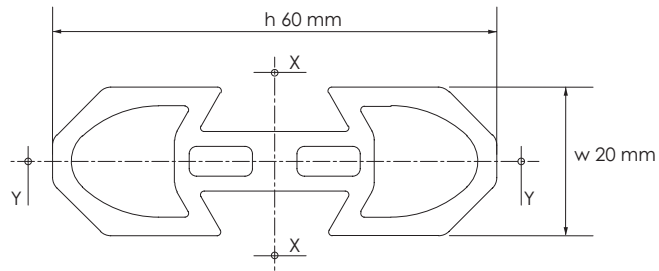

Fig. 24

Surface quadratic moments: X-X axis = 138.600 mm⁴ / Y-Y axis = 18.000 mm⁴.

Max. manufacturing tolerances = ± 0.15 mm across opposite rolling surfaces.

Max. angular distorsion = $\pm 20'$ /m.

Linear mass = 1.27 Kg/m.

Max. linear distorsion = ± 0.4 mm/m.

Standard lengths: 1000-1500-2000-2500-3000-3500-4000-4500-5000-5500-6000-6500-7000 mm.

Ext. surface: deep hard anodizing

> "Speedy Rail Mini" roller assemblies and components

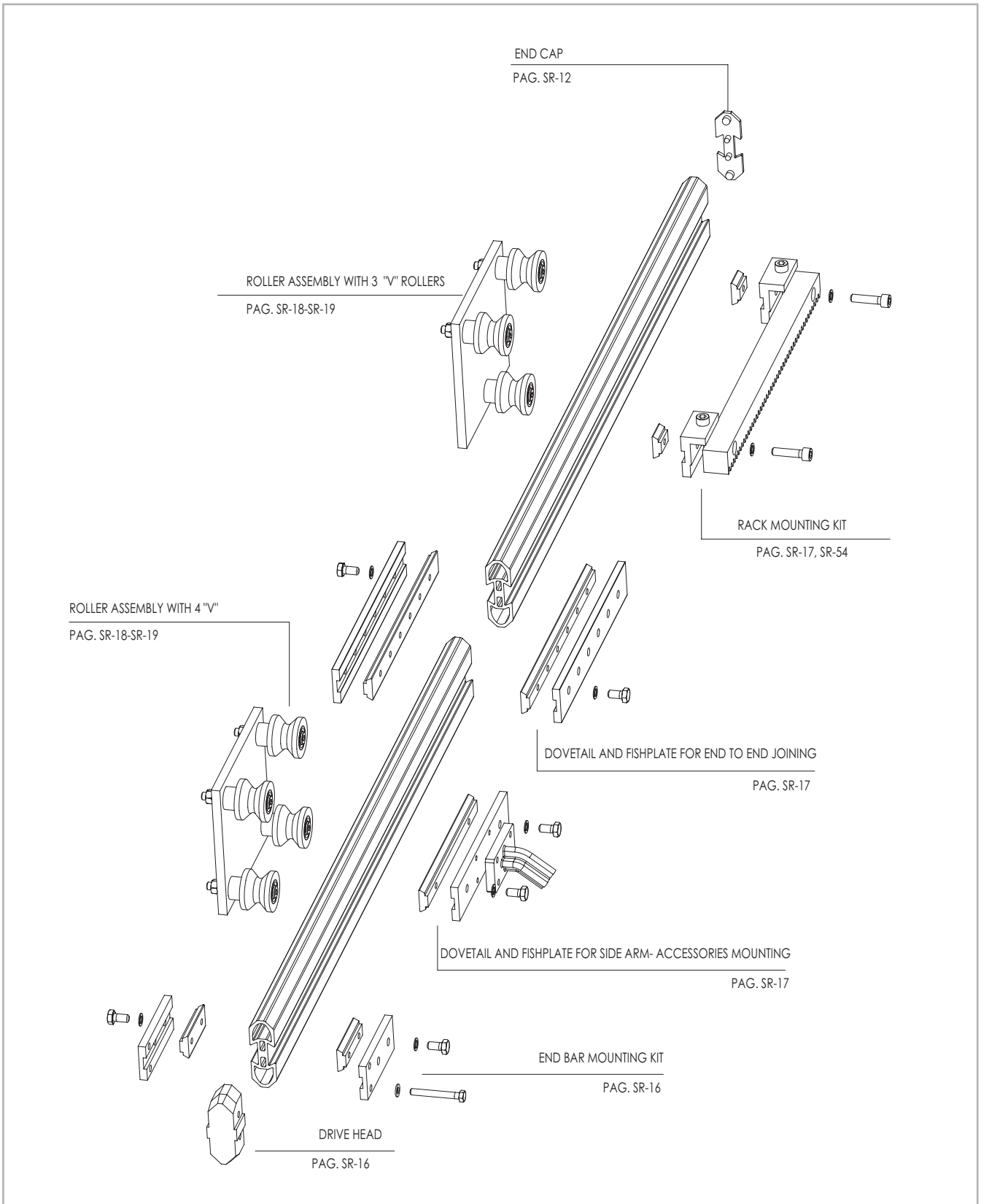

Fig. 25

S
R

> "Speedy Rail Mini" guide and components

Mini speedy rail with plain ends

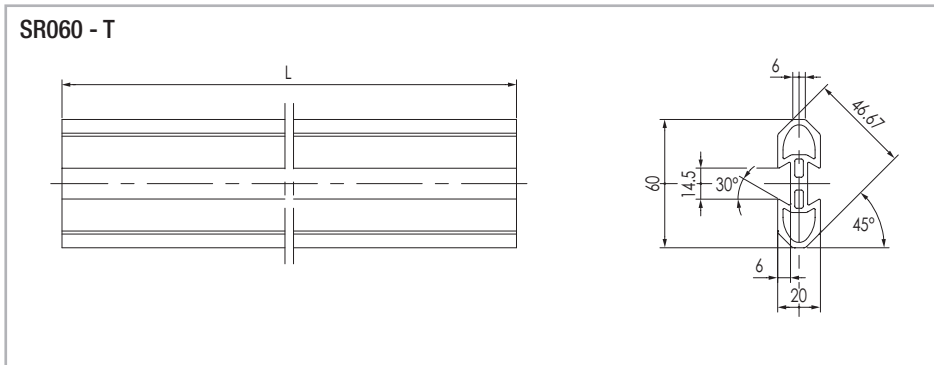

Fig. 26

Mini speedy rail with drilled ends

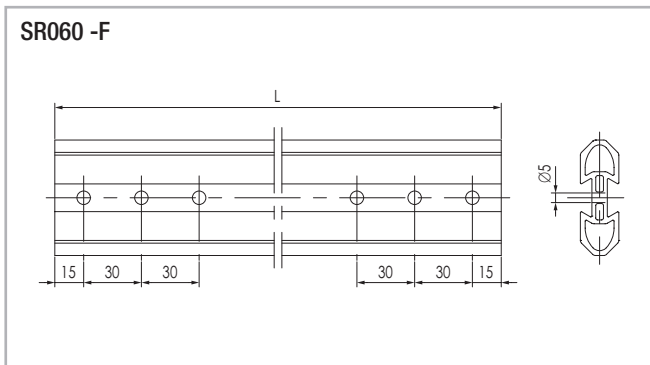

Fig. 27

Nota: drillings on the guide end are required as a safety measure with end-to-end joining in moving rails.
See technical note on page SR-68

Fishplate for drive head

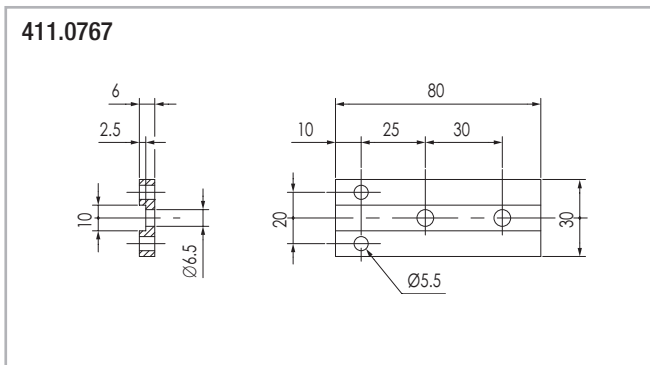

Fig. 28

M6 allen round head screw

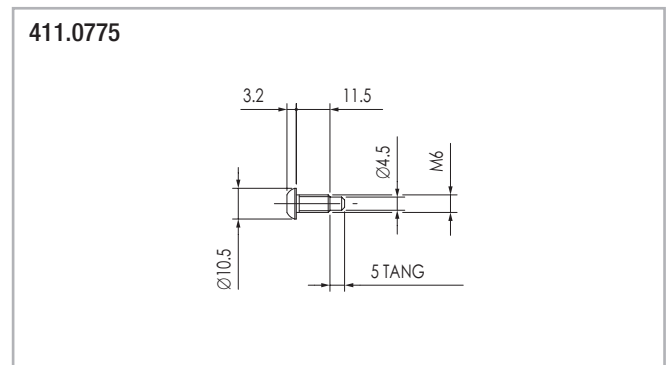

Fig. 29

Drive head

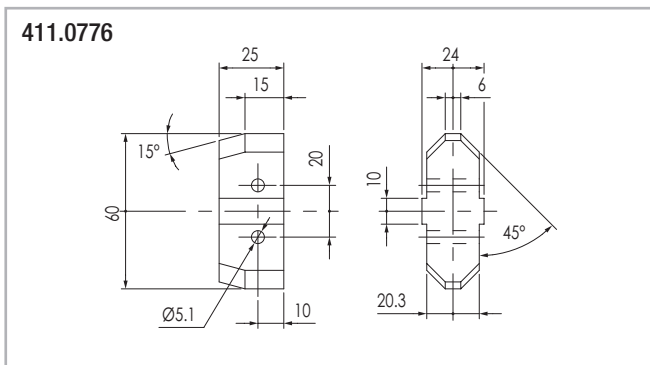

Fig. 30

End cap

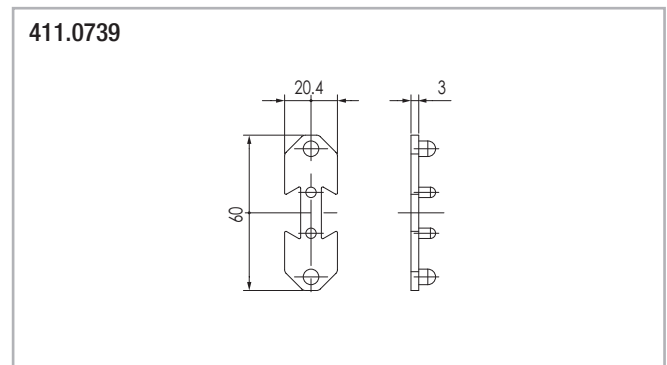

Fig. 31

Bolt for drive head mount

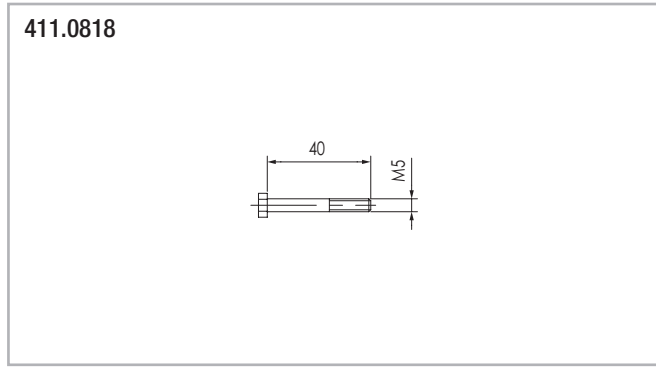

Fig. 32

> Dovetail clamps and fishplates

Dovetail clamps

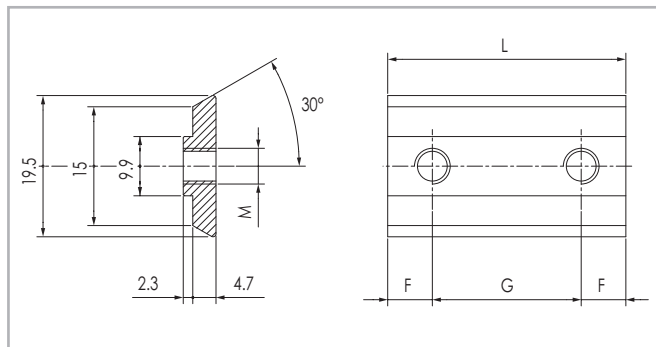
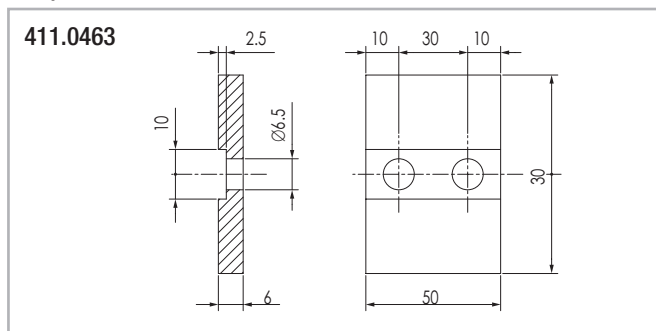

Fig. 33

Fishplate



Material: hard anodized aluminium alloy

Fig. 34

Fishplate for end to end joining

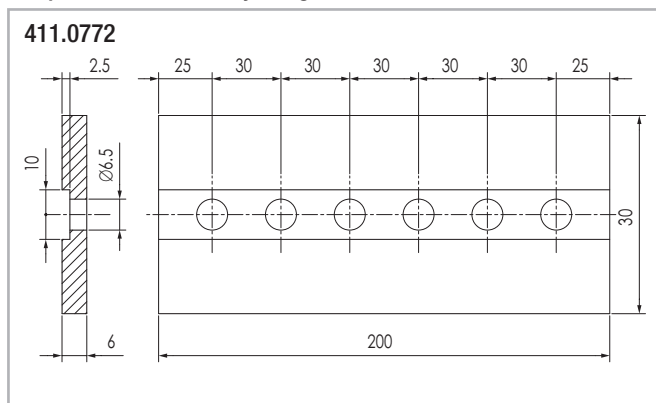

Material: hard anodized aluminium alloy

Fig. 35

Code N°	N° Holes	F	G	L	M	Material
411.1732	1	10	/	20	M4	Burnished steel
411.2732	1	10	/	20	M5	
411.2733	9	8	60	496	M5	
411.0732	1	10	/	20	M6	
411.0768	2	15	30	60	M6	
411.0754	3	10	30	80	M6	
411.0769	6	25	30	200	M6	
411.0771	2	25	100	150	M6	
411.0462	2	10	30	50	M6	
411.3532	1	10	/	20	M8	

Tab. 4

Dovetail quick front insertion

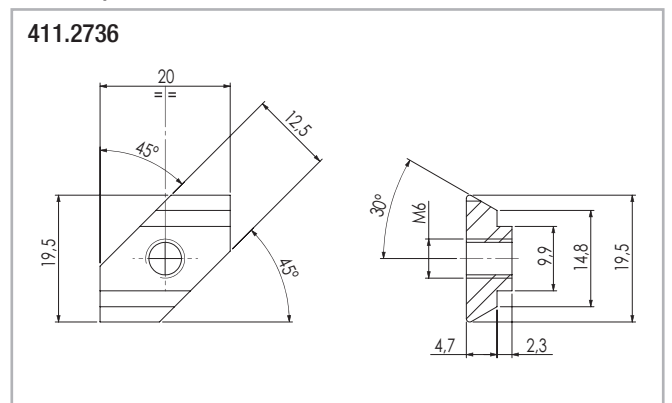

Material: hard anodized aluminium alloy

Fig. 36

Fishplate for side-arm attachment

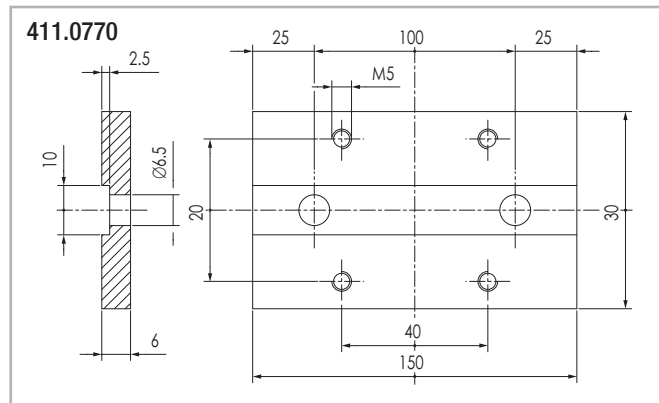

Material: hard anodized aluminium alloy

Fig. 37

Plate for m2 rack mounting

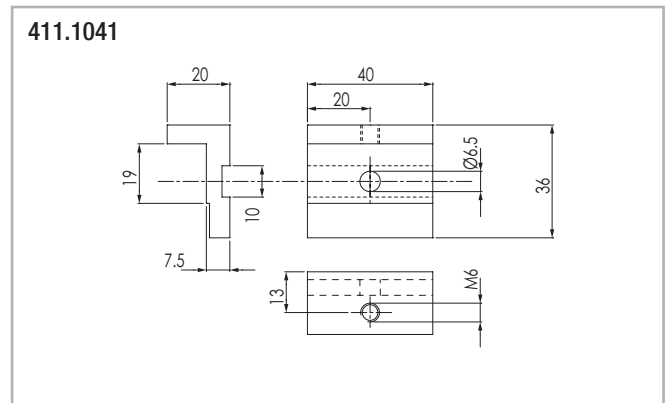
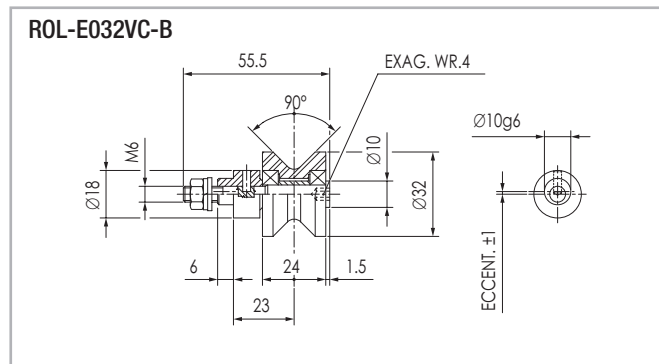

Fig. 38

> Roller assembly and "V" rollers "Light"

Plastic compound eccentric roller



Max. load: radial 270 N axial 100 N

Fig. 39

Plastic compound concentric roller

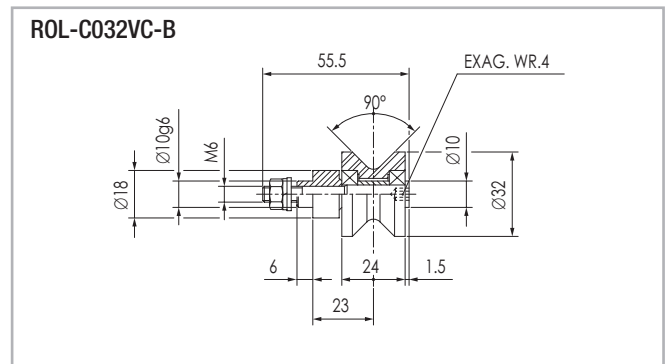

Max. load: radial 270 N axial 100 N

Fig. 40

For axially free roller see page SR-12 (55.1072 CONC. - 55.1073 ECC.)

Roller assembly with 3 rollers

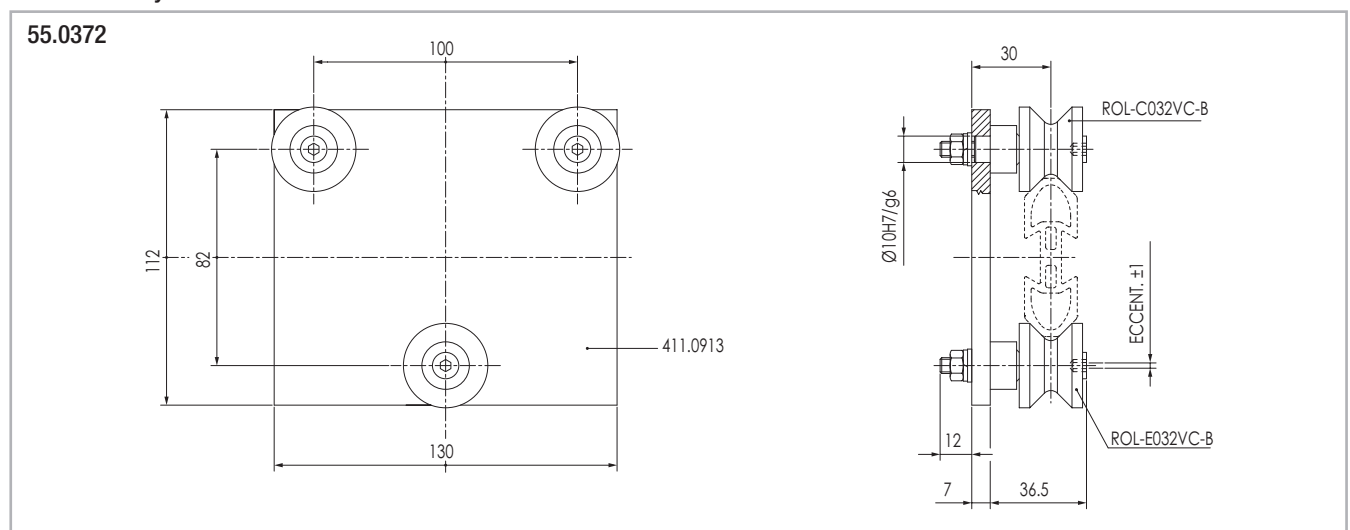

Fig. 41

Roller assembly with 4 rollers

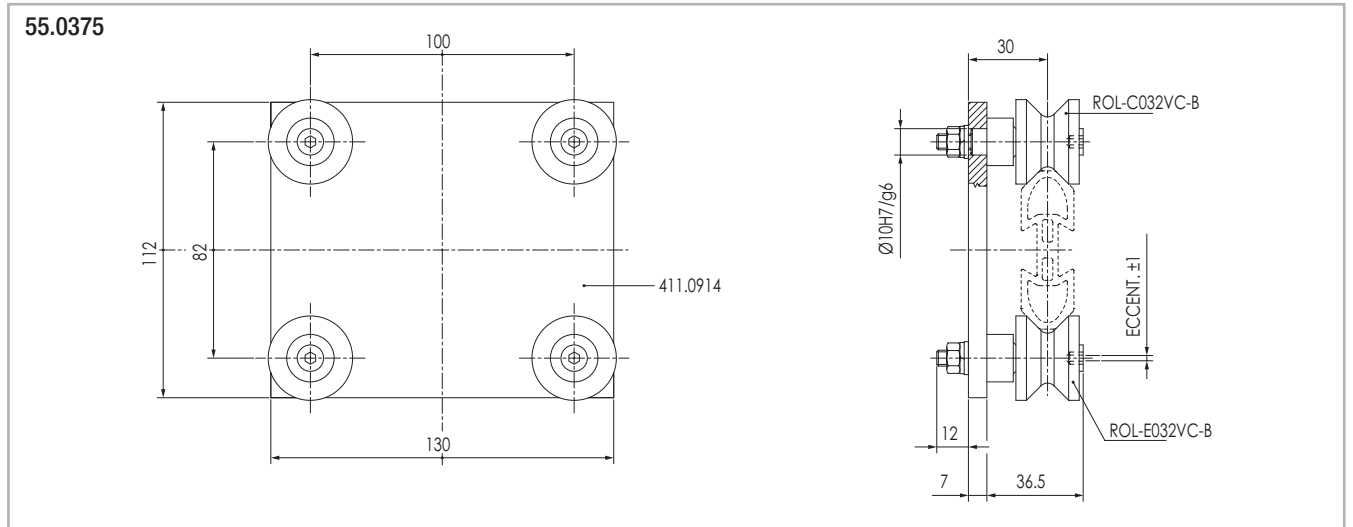
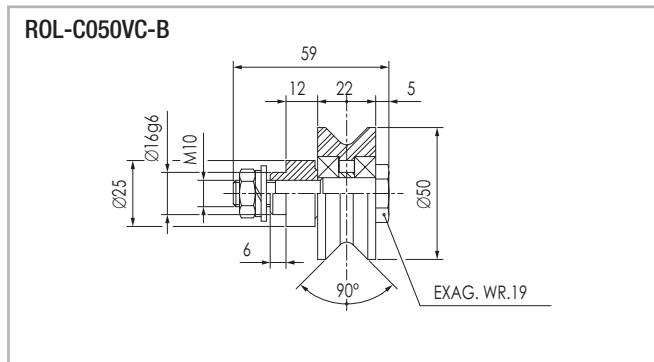

Fig. 42

> Roller assemblies and "V" rollers

Plastic compound concentric roller



Max. load: radial 400 N axial 100 N

Fig. 43

Plastic compound eccentric roller

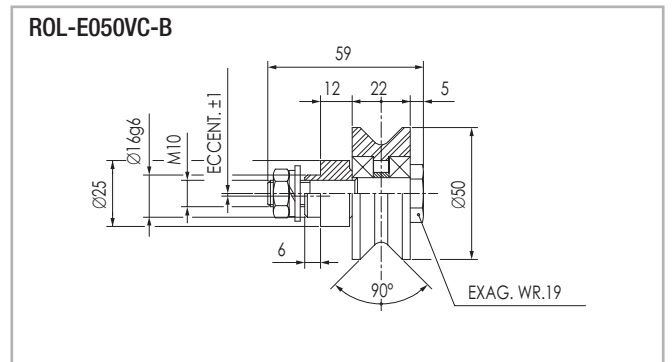

Max. load: radial 400 N axial 100 N

Fig. 44

Roller assembly with 3 rollers

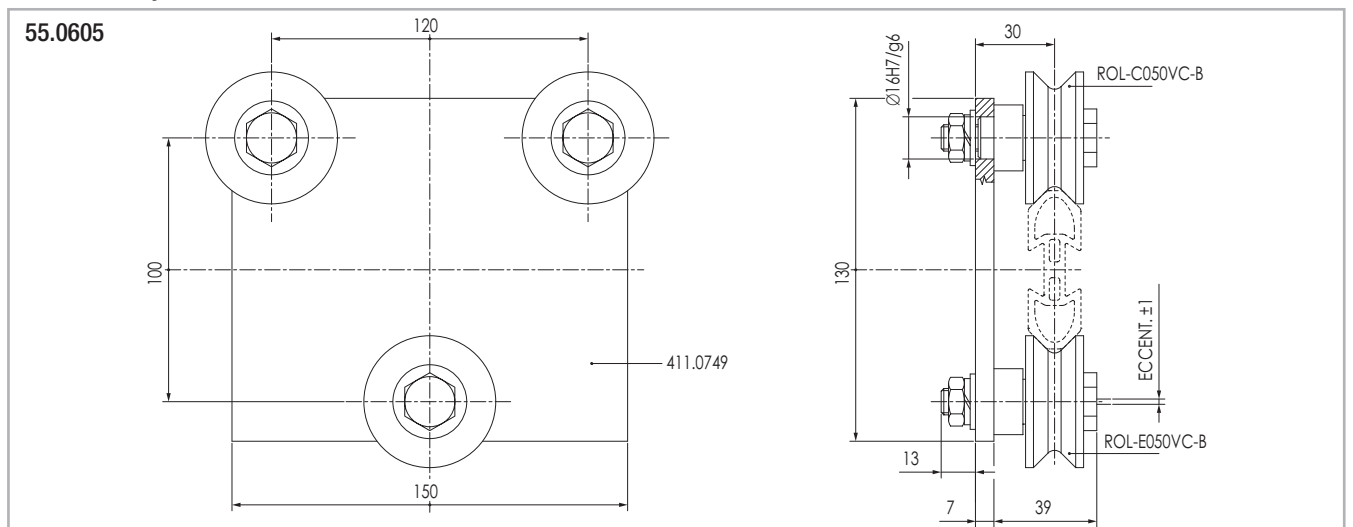

Fig. 45

Roller assembly with 4 rollers

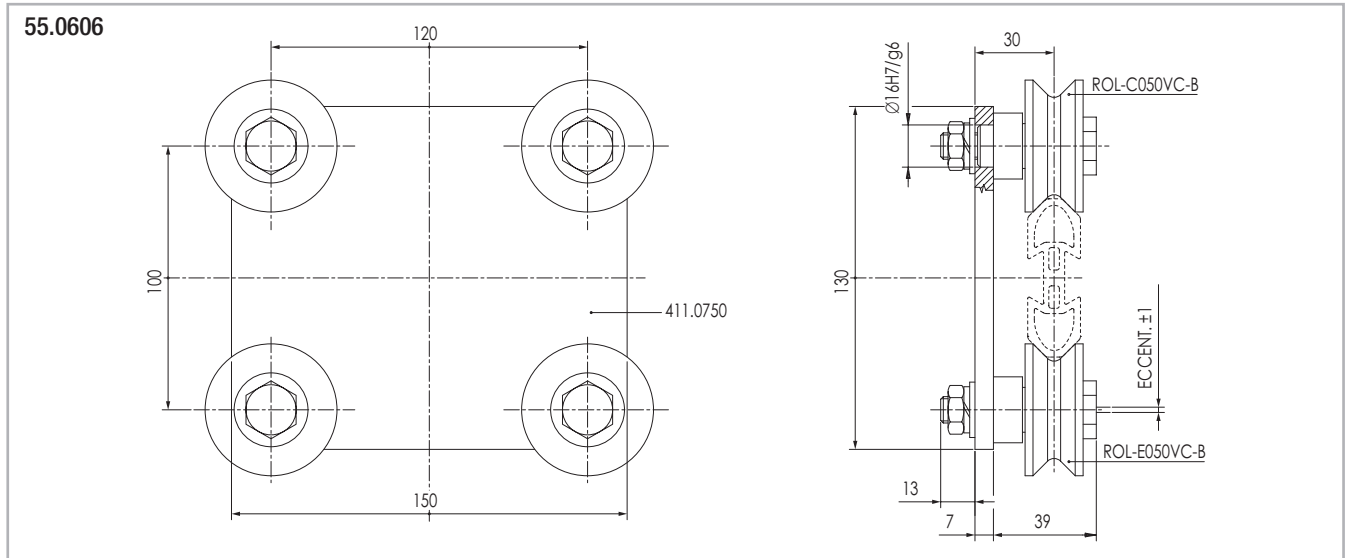

Fig. 46

Speedy Rail 90



> "Middle Speedy Rail" guide and specifications

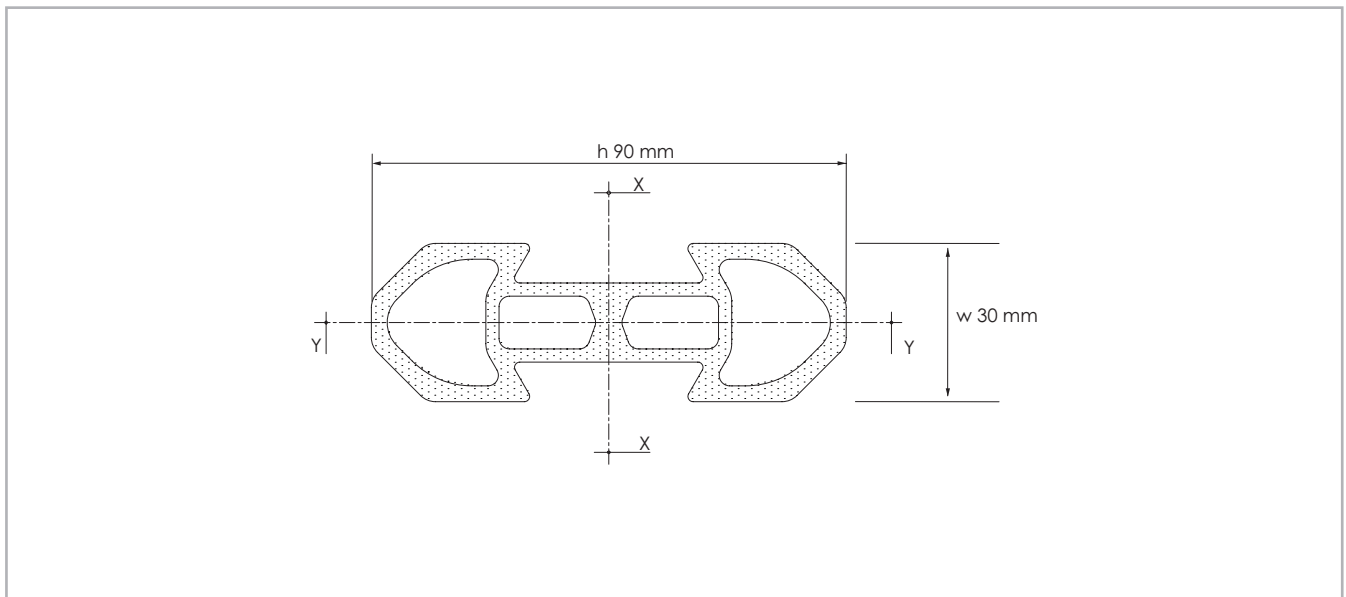

Fig. 47

Surface quadratic moments: X-X axis = 630.000 mm⁴ / Y-Y axis = 76.500 mm⁴.

Max. manufacturing tolerances = ± 0.20 mm across opposite rolling surfaces.

Max. angular distortion = $\pm 20'$ /m.

Linear mass = 2.6 Kg/m.

Max. linear distortion = ± 0.4 mm/m.

Standard lengths: 1000-1500-2000-2500-3000-3500-4000-4500-5000-5500-6000-6500-7000-7500 mm.

External surface: deep hard anodizing

> "Middle Speedy Rail" assemblies and components

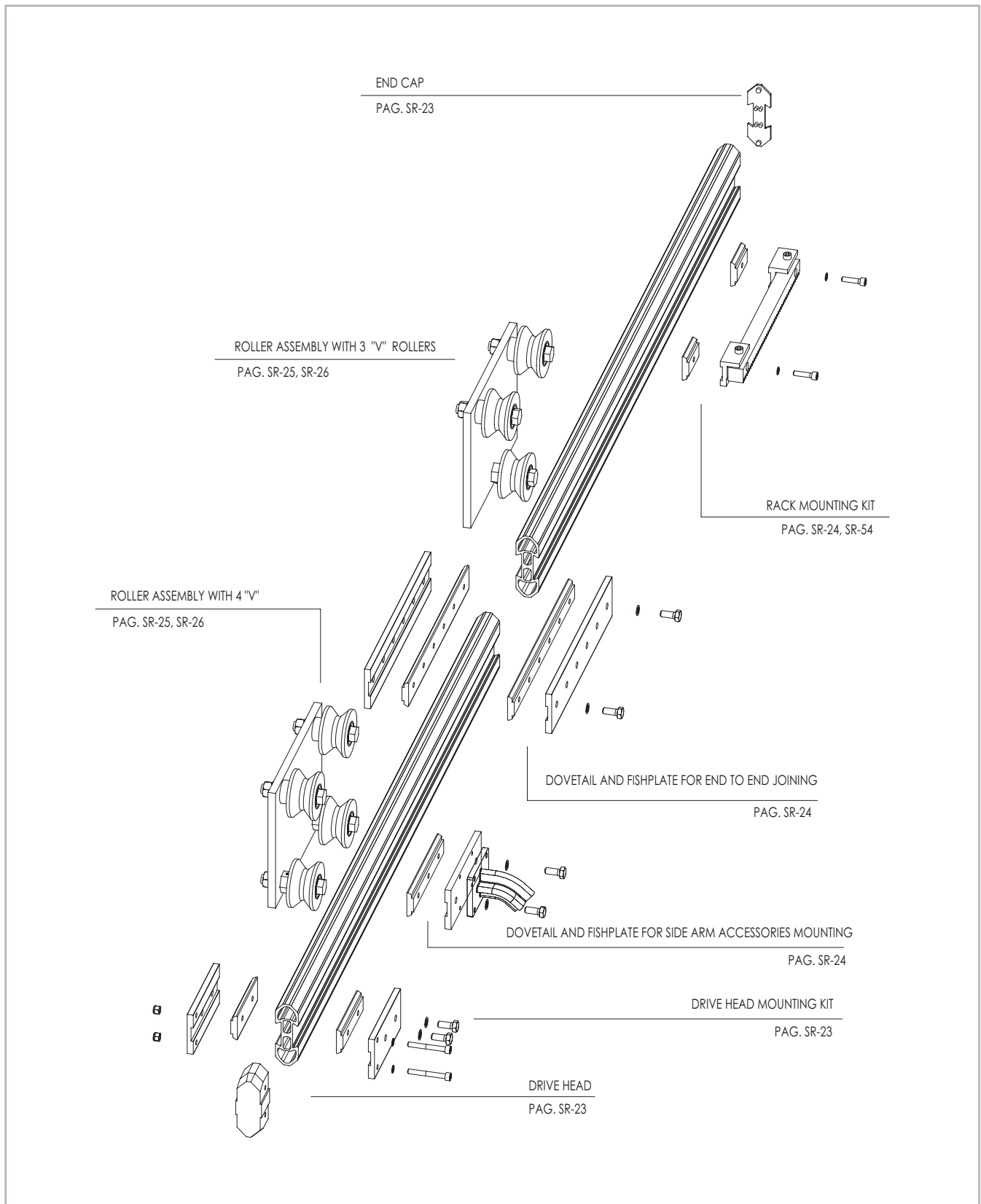

Fig. 48

> "Middle Speedy Rail" guide and components

Middle Speedy Rail with plain ends



Fig. 49

Middle Speedy Rail with drilled ends

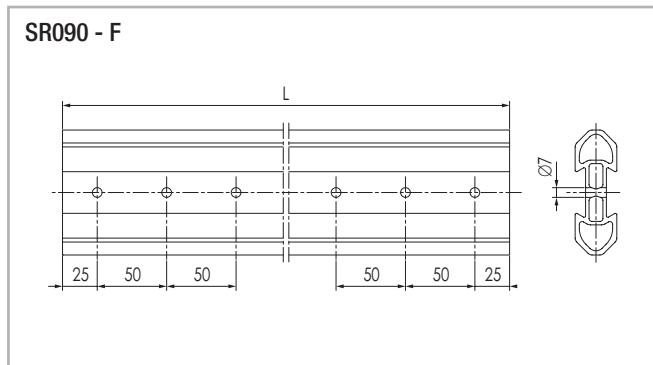

Fig. 50

Note: drillings on the guide end are required as a safety measure with end-to-end joining in moving rails.
See technical note on page SR-68

Fishplate for drive head

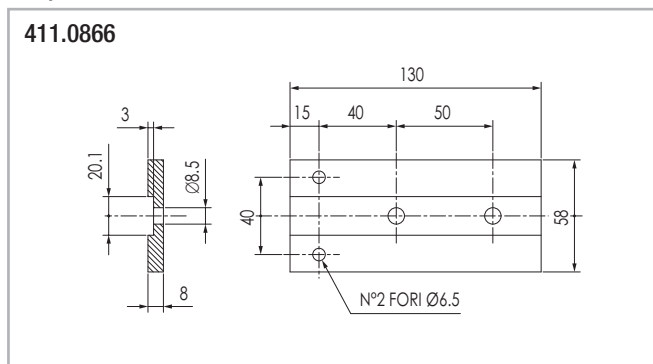

Fig. 51

Drive head

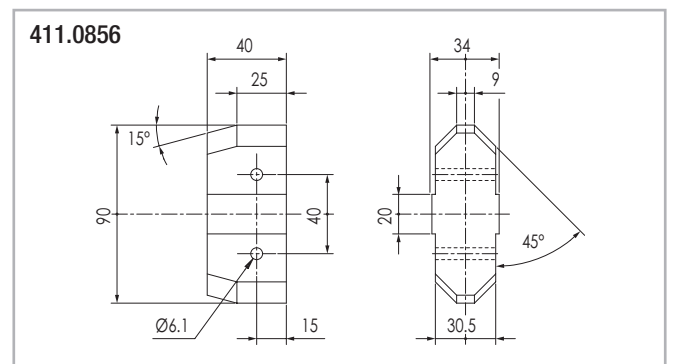

Fig. 52

End cap

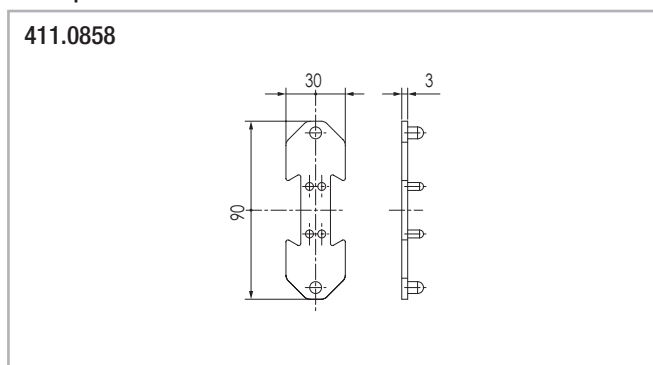

Fig. 53

Bolt for drive head mount

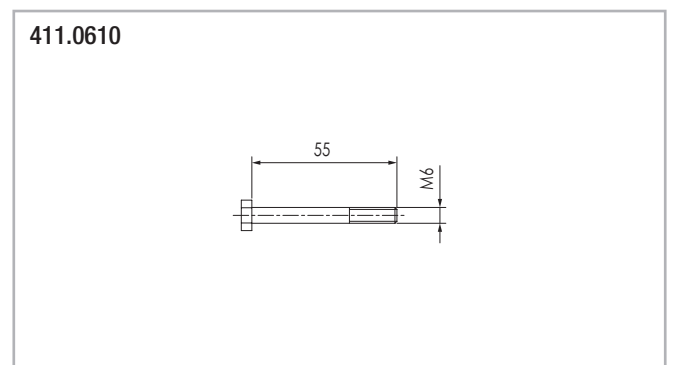

Fig. 54

> Dovetail clamps and fishplates

Dovetail Clamp

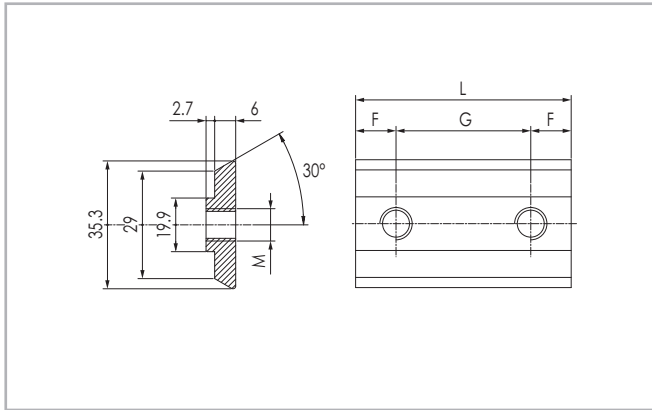

Fig. 55

Code N.	N° Holes	F	G	L	M	Material
411.1025	1	25	/	50	M4	Burnished steel
411.1047	1	25	/	50	M6	
411.1045	1	25	/	50	M8	
411.1069	2	25	50	100	M8	
411.1088	3	25	50	150	M8	
411.1072	4	25	50	200	M8	
411.1070	6	25	50	300	M8	

Tab. 5

Dovetail-execution without step

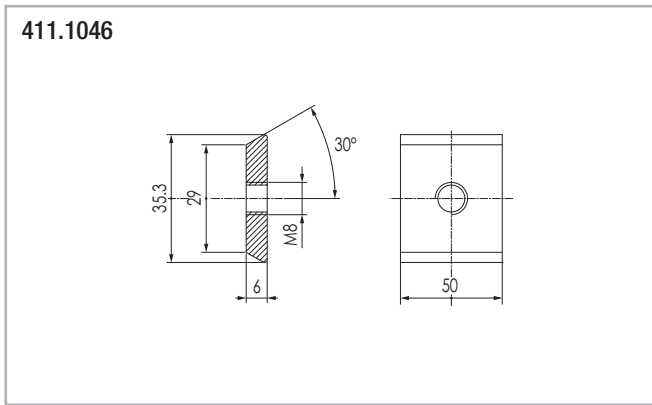

Fig. 56

Dovetail-quick front insertion version

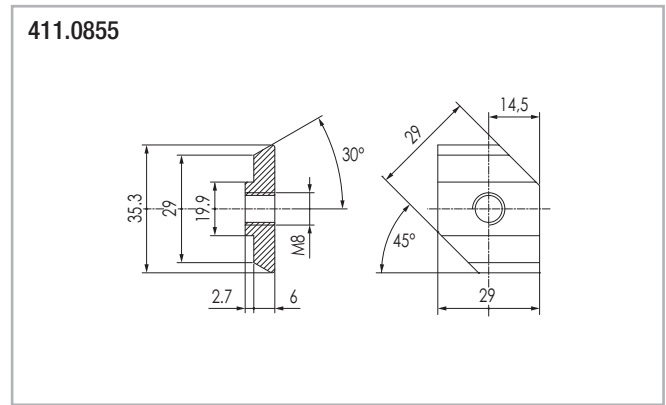
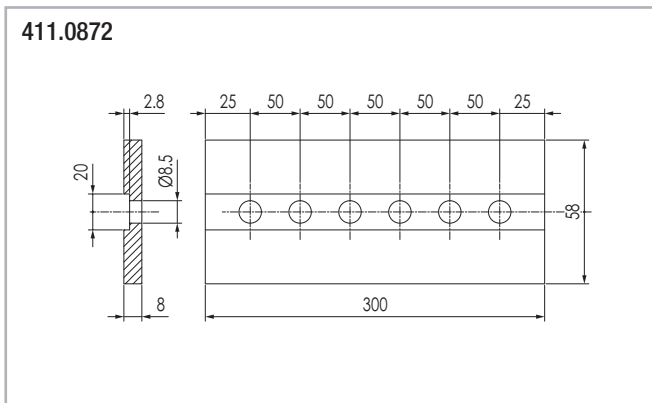

Fig. 57

Fishplate for end to end joining



Material: hard anodized aluminium alloy

Fig. 58

Fishplate for side-arm attachment

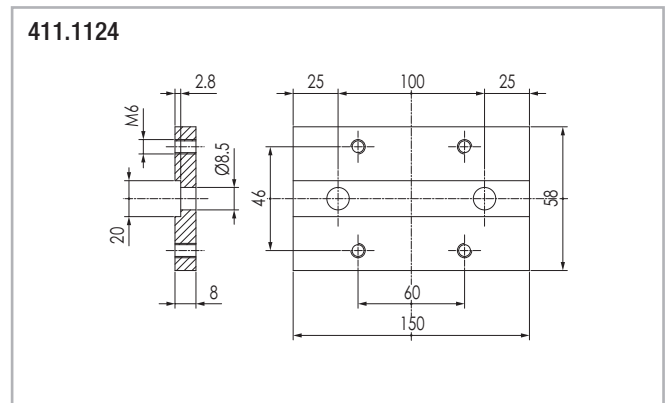

Material: hard anodized aluminium alloy

Fig. 59

Steel plate for m2 rack mounting

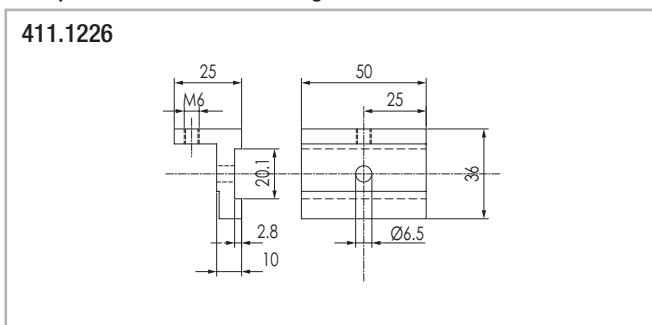
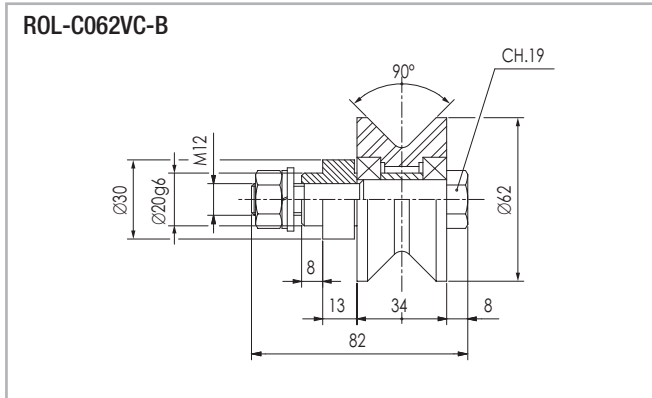

Fig. 60

> Plastic compound shell "V" rollers

Concentric roller



Max. load: radial 450 N/axial 150 N

Fig. 61

Eccentric roller

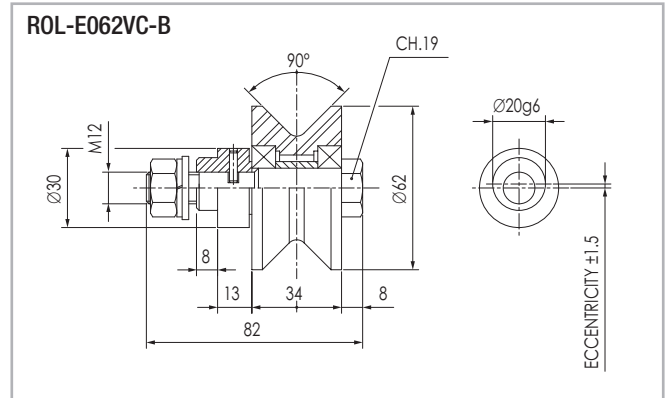

Max. load: radial 450 N/axial 150 N

Fig. 62

Concentric roller heavy duty

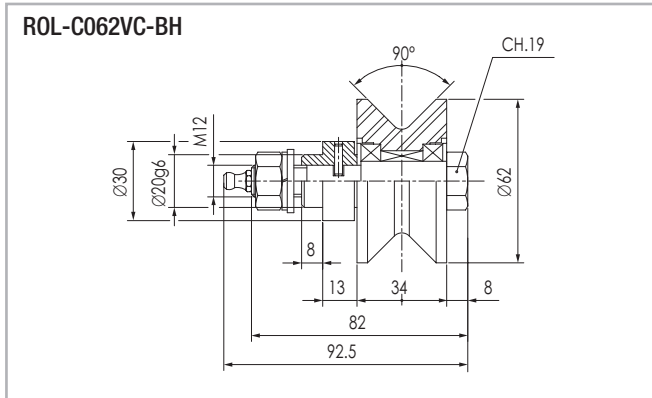

Max. Load: radial 700 N/axial 280 N - Optional lifetime lubrication

Fig. 63

Eccentric roller heavy duty

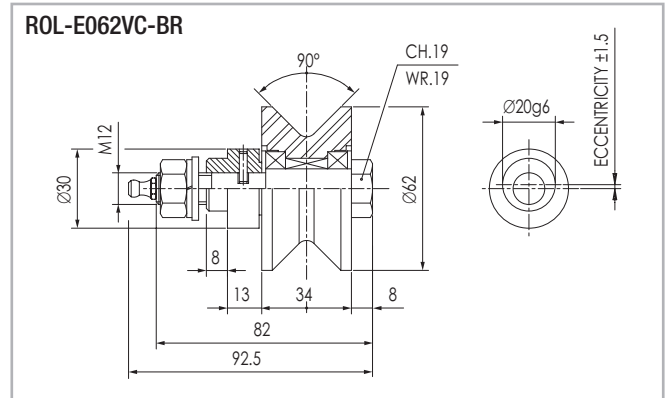

Max. Load: radial 700 N/axial 280 N - Optional lifetime lubrication

Fig. 64

Concentric roller axially free ±1.75 mm

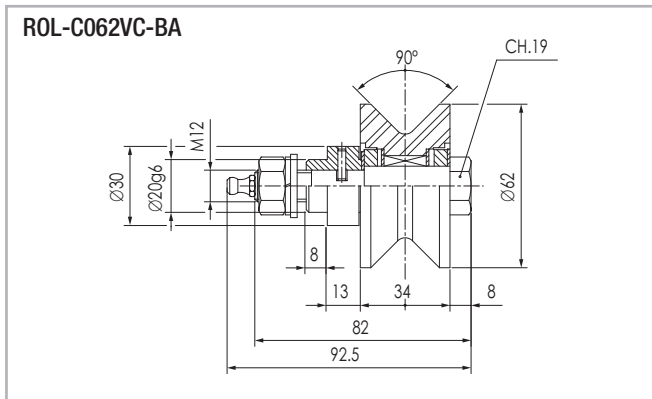

Max. radial load: 700 N - Optional lifetime lubrication

Fig. 65

Eccentric roller axially free ±1.75 mm

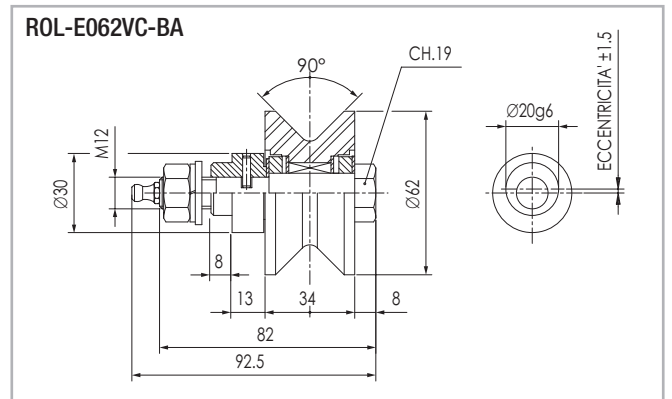

Max. radial load: 700 N - Optional lifetime lubrication

Fig. 66

> **Roller assembly with "V" shaped rollers**

Roller assembly with 4 rollers

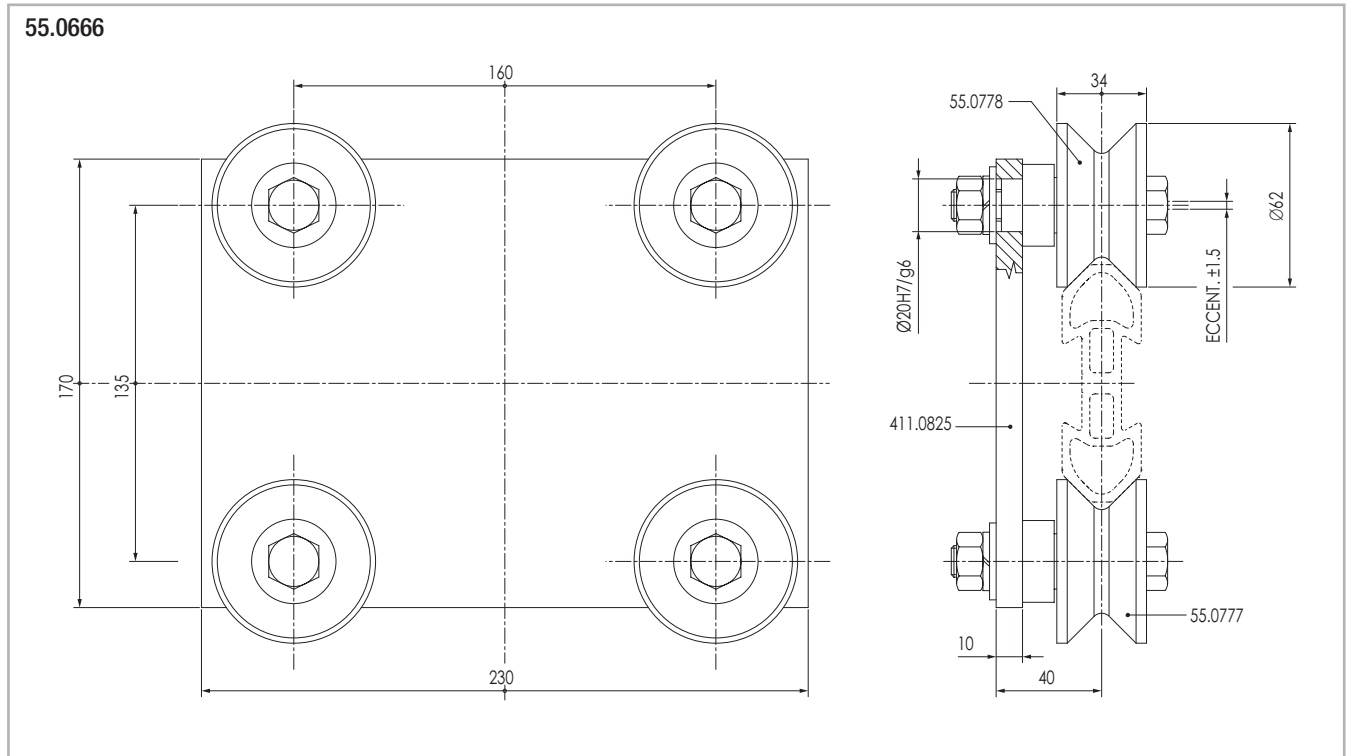

Fig. 67

Roller assembly with 3 rollers

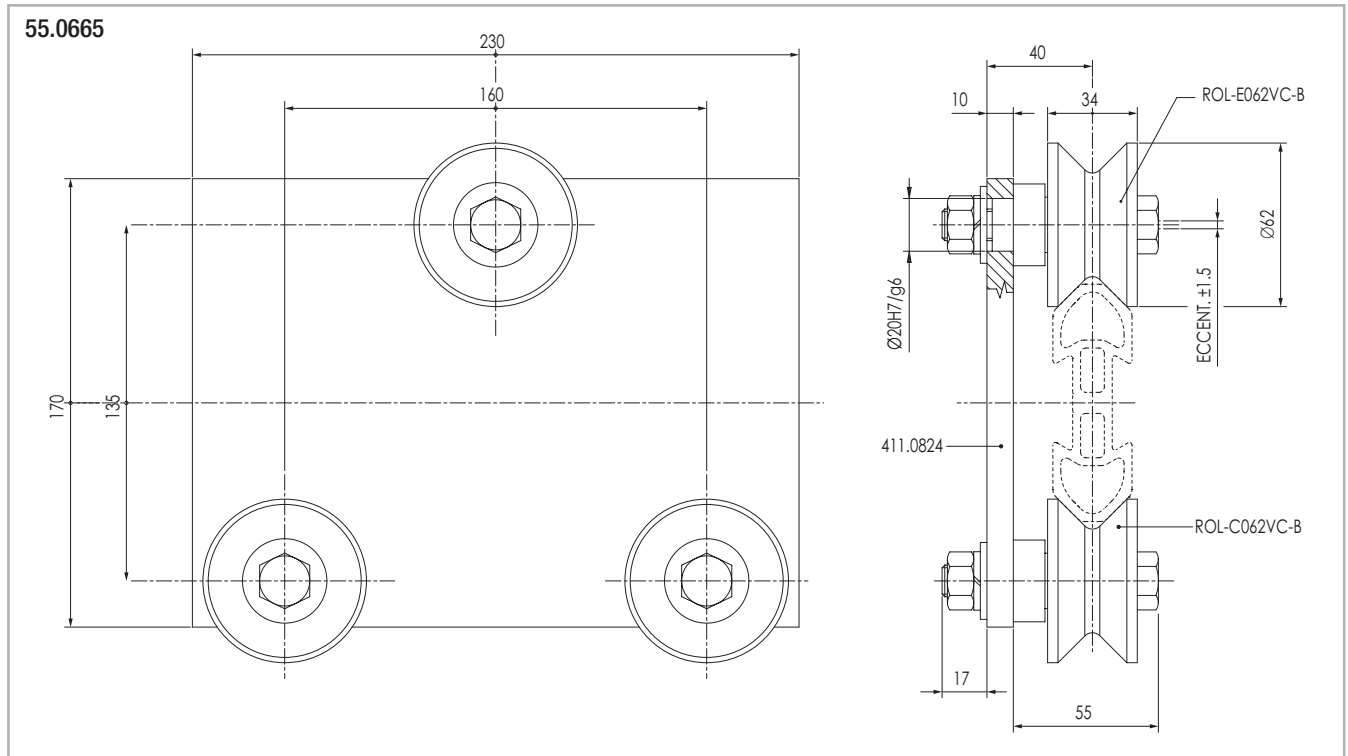

Fig. 68

The plates - cod. 411.0825 and 411.0824 - are made in aluminium alloy with hard anodization. The rollers -cod. 55.0387, 55.0388, 55.0130 55.0131- and/or different combinations from the ones shown on this page can be mounted on the above plates. Please call our technical dept. Prior any configuration changes.

Speedy Rail 120



> "Standard Speedy Rail" guide and specifications

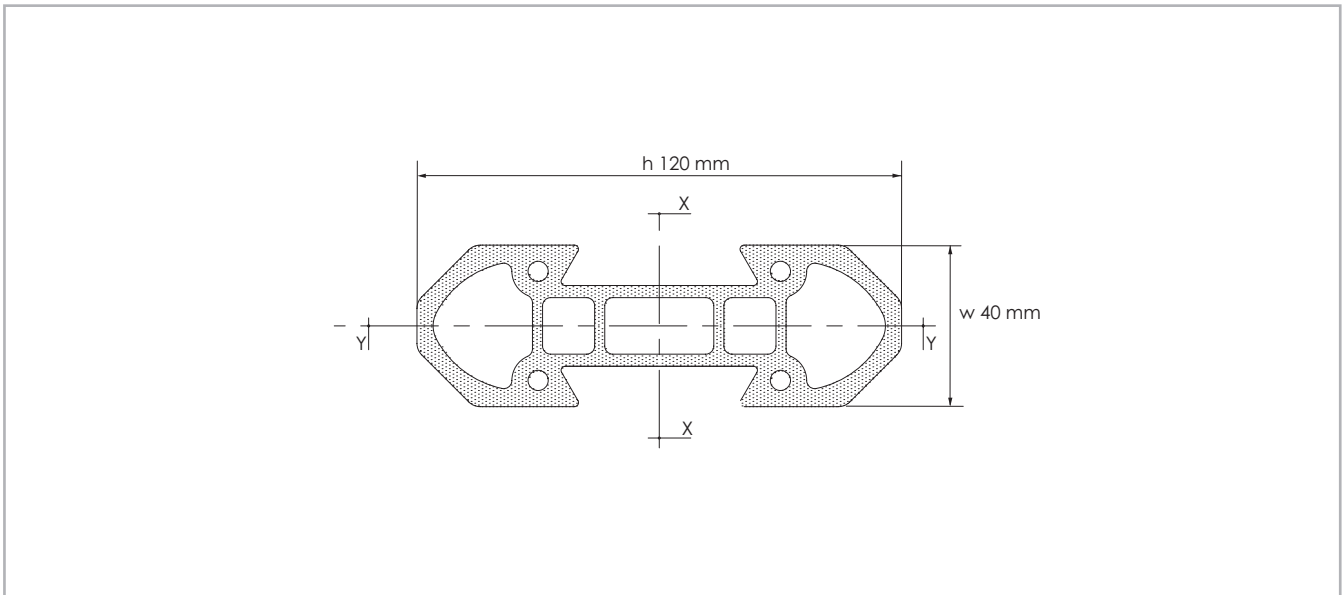

Fig. 69

Surface quadratic moments: X-X axis = 2.138.988 mm⁴ / Y-Y axis = 259.785 mm⁴.

Max. manufacturing tolerances = ± 0.20 mm across opposite rolling surfaces.

Max. angular distortion = $\pm 20'$ /m.

Linear mass = 4.4 Kg/m.

Max. linear distortion = ± 0.5 mm/m.

Standard lengths: 1000-1500-2000-2500-3000-3500-4000-4500-5000-5500-6000-6500-7000-7500 mm.

External surface: deep hard anodizing

> "Standard Speedy Rail" assemblies and components

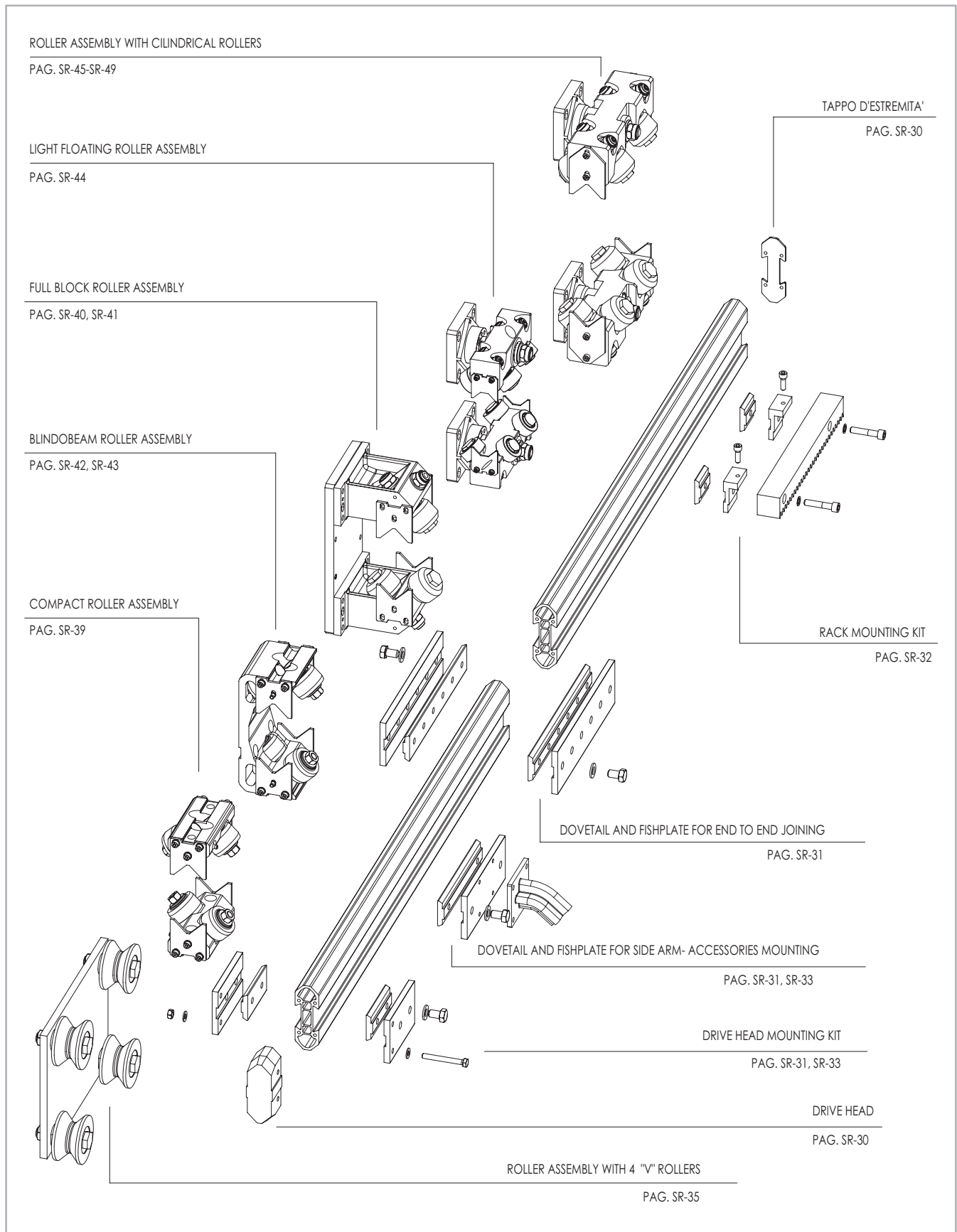

Fig. 70

> "Standard Speedy Rail" guide and specifications

Standard Speedy Rail with plain ends

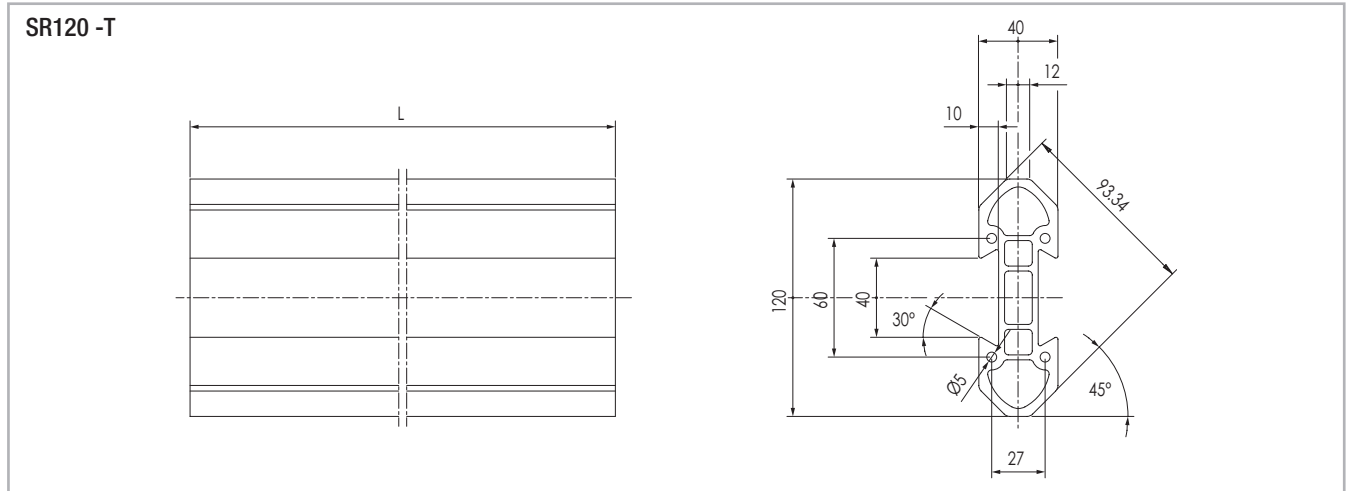

Fig. 71

Standard Speedy Rail with drilled ends

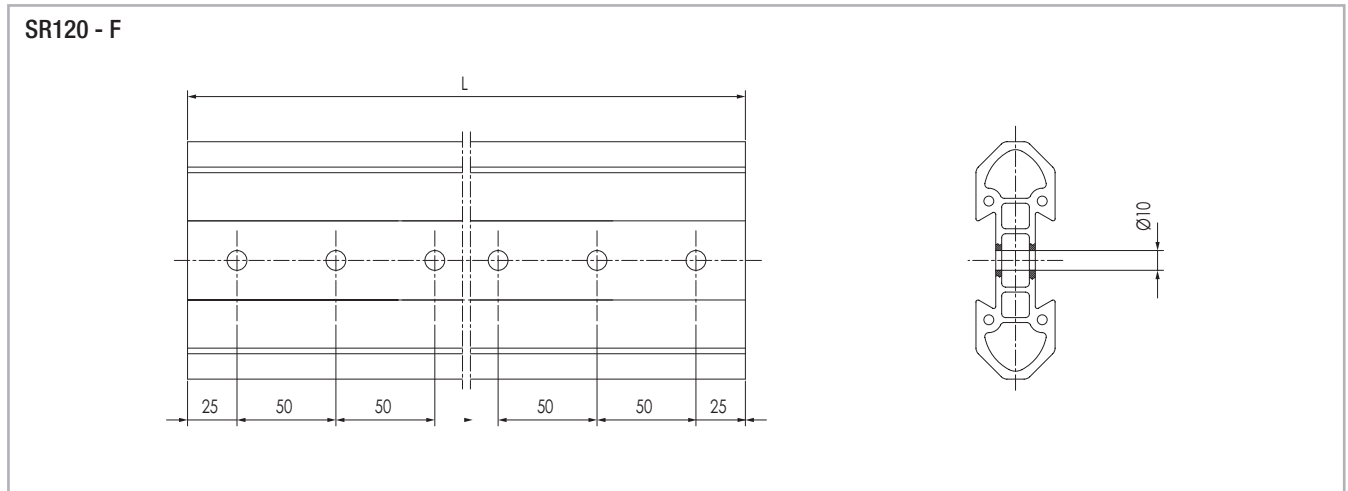

Fig. 72

Note: drillings on guide end are required as a safety measure with end-to-end joining in moving rails.

> Components for speedy rail SR120 guide

Drive head

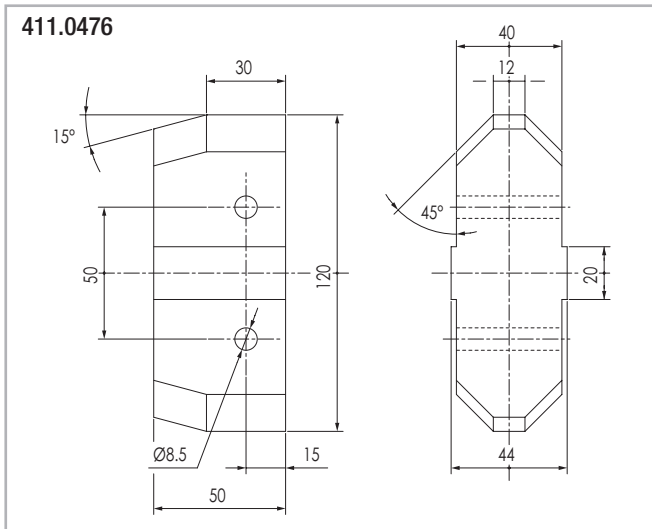

Fig. 73

Bolt for drive head

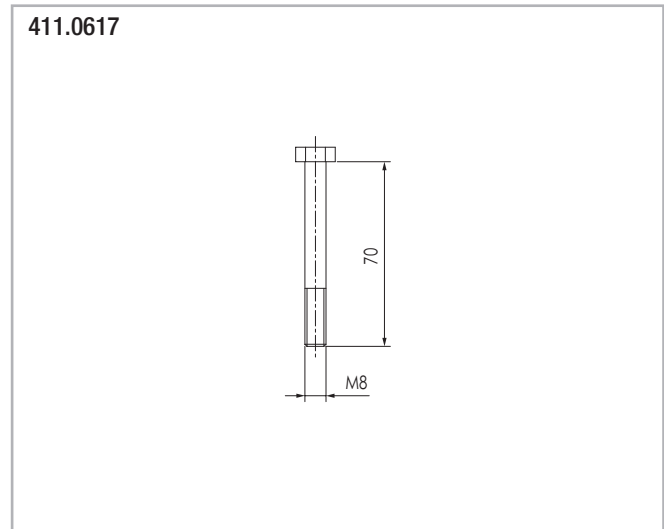

Fig. 74

Aluminium alloy end cap

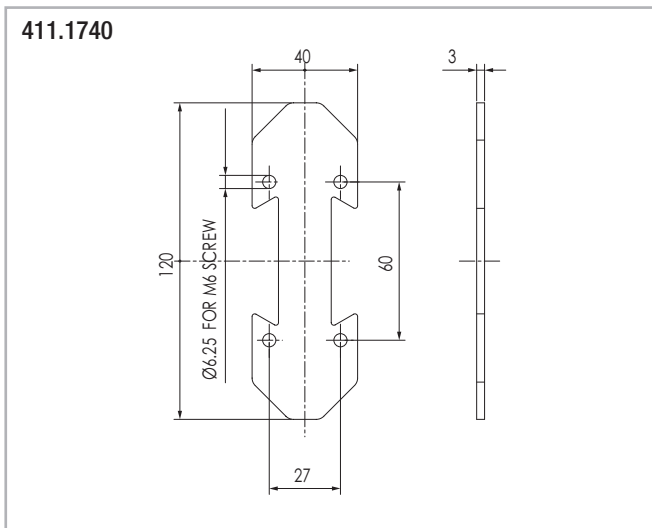

Fig. 75

> Standard dovetail clamps

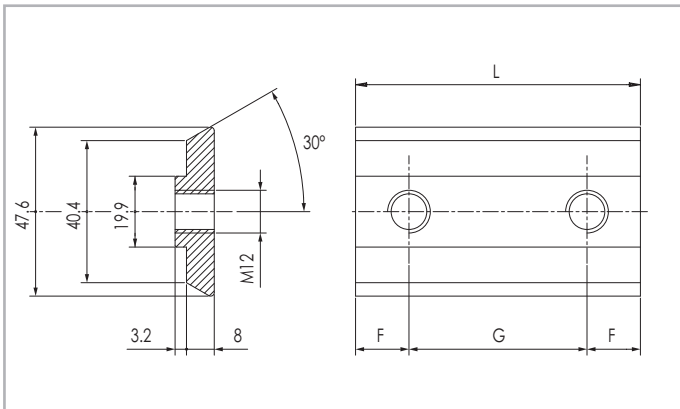

Fig. 76

Code N.	N° Holes	F	G	L	Material
411.0845	1	25	/	50	Burnished steel
411.0745	1	25	/	50	
411.0503	2	15	40	70	
411.0469	2	25	50	100	
411.0588	3	25	50	150	
411.0472	2	25	150	200	
411.0470	6	25	50	300	

Tab. 6

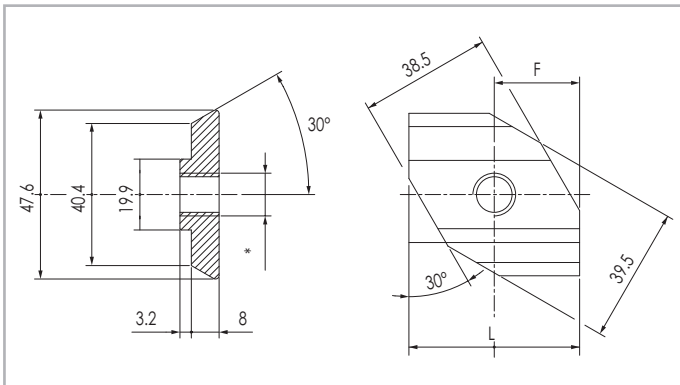

Fig. 77

411.1178

* M10 dovetail-quick front-insertion version

411.0845

* M12 dovetail-quick front-insertion version

Dovetail clamps with M8 threaded holes

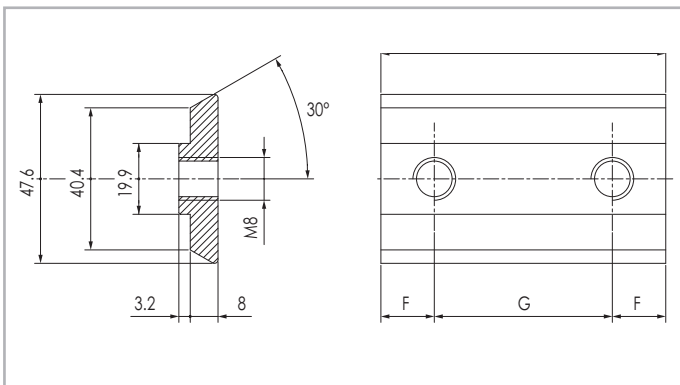

Fig. 78

Code N.	N° Holes	F	G	L	Material
411.0675	2	15	20	50	Burnished steel
411.1111	1	25	/	50	
411.1112	2	25	50	100	
411.1113	3	25	50	150	
411.0970	6	25	50	300	

Tab. 7

Dovetail clamps with M10 threaded holes

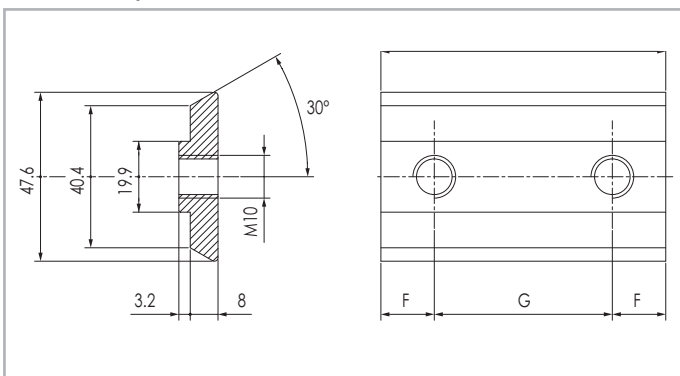

Fig. 79

Code N.	N° Holes	F	G	L	Material
411.1117	1	25	/	50	Burnished steel
411.1119	2	25	50	100	
411.1120	3	25	50	150	

Tab. 8

Steel dovetail without step

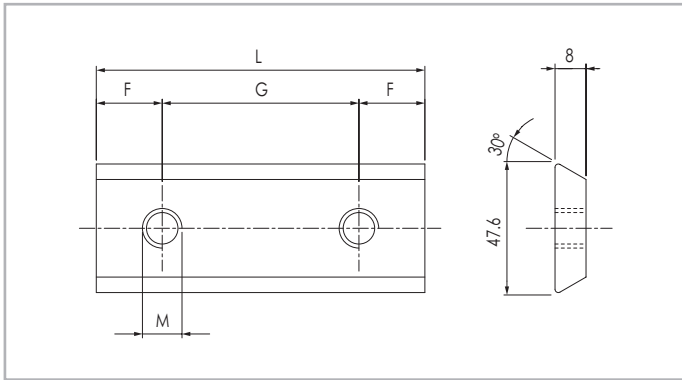

Fig. 80

Code N.	N° Holes	F	G	L	M	Material
411.1675	2	15	20	50	M8	Burnished steel
411.1186	1	25	/	50	M10	
411.1185	1	25	/	50	M12	
411.0888	3	25	50	150	M12	

Tab. 9

Steel dovetail quick front insertion without step

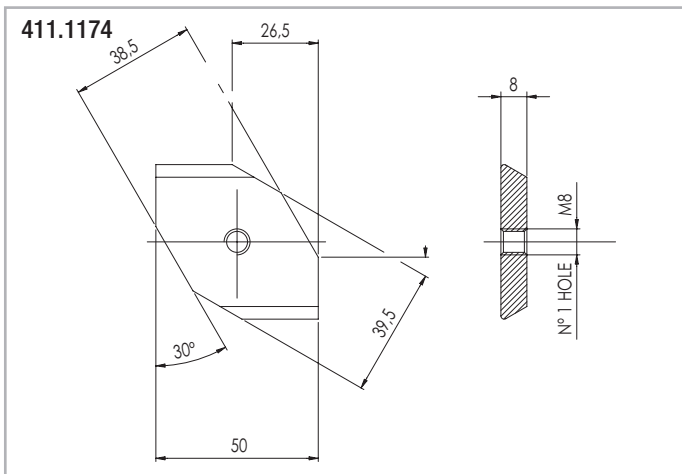

Fig. 81

> Racks components for rigid mounting

Fishplate for mod.3-4 rack mounting on dovetail grooves

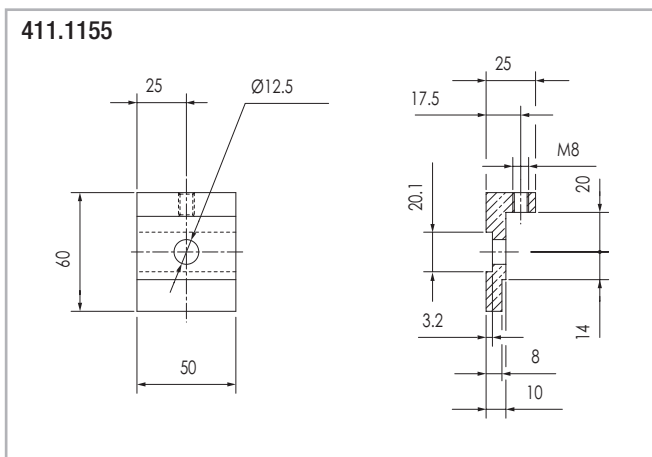

Fig. 82

For rack mounting plate mod.3 Use dovetail 411.1111

For rack mounting plate mod.4 Use dovetail 411.1117

For standard racks see page SR-52; For dovetail see page SR-31, SR-32; For insert see page SR-56

> Standard fixing fishplates

Side attachment fishplate suitable for: speedy rail standard, wide body, super wide body

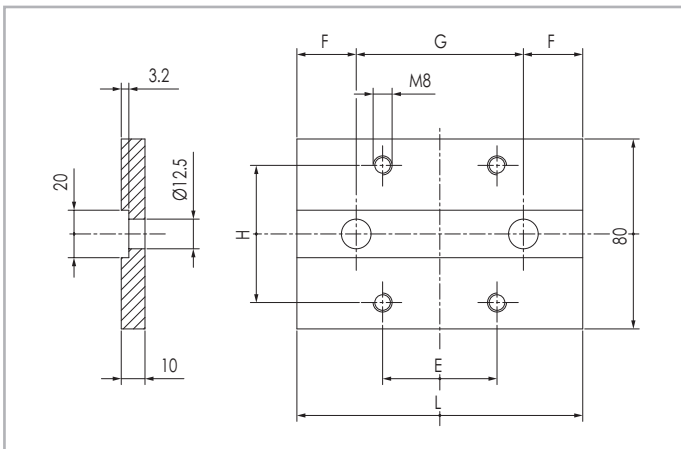

Fig. 83

Code N.	E	F	G	H	L	Material
411.0570	70	25	150	60	200	Hard anodized aluminium alloy

Tab. 10

Fishplates for end to end joining suitable for speedy rail standard, wide body, super wide body

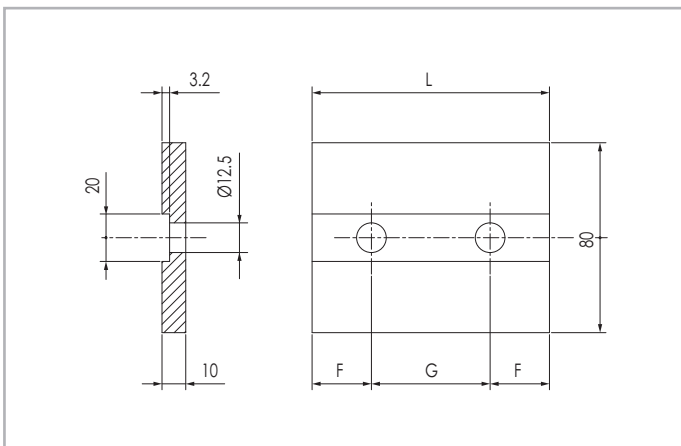

Fig. 84

Code N.	N° Fori	L	F	G	Material
411.0572	6	300	25	50	Hard anodized aluminium alloy
411.0690	6	300	25	50	Burnished steel
411.0573	6	300	25	50	Steel/countersuk holes

Tab. 11

Fishplate for drive head

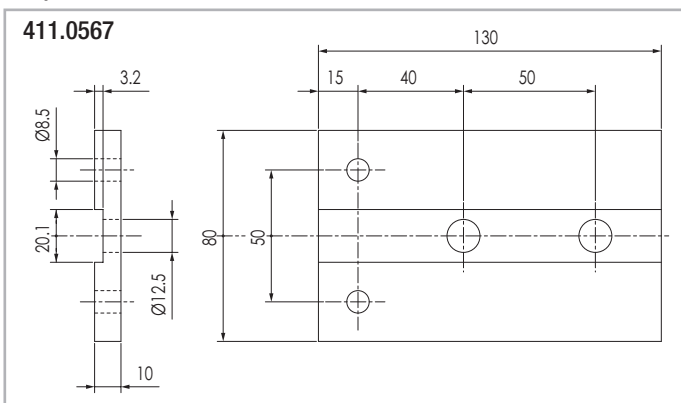

Fig. 85

M12 exag. head screw

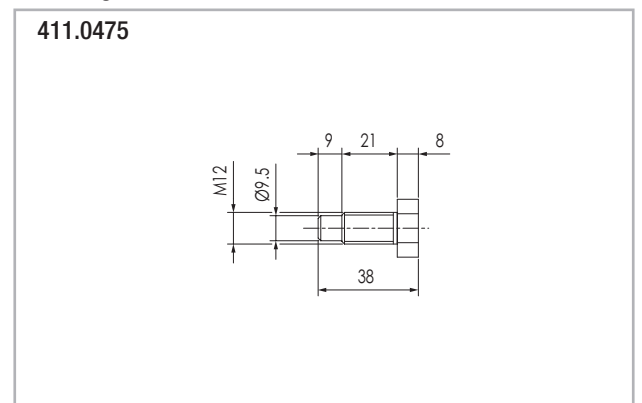
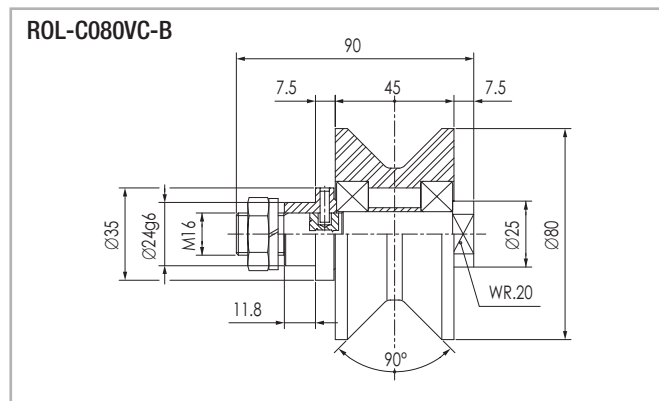

Fig. 86

> Plastic compound shell "V" rollers

Concentric roller



Radial load 700 N max. axial load 200 N max. - lifetime lubrication **Fig. 87**

Eccentric roller

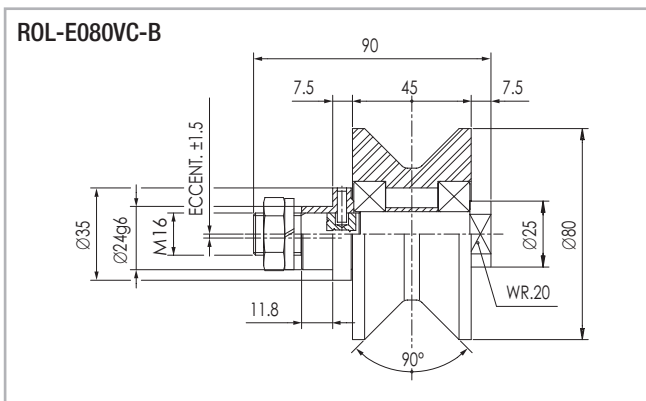

Radial load 700 N max. axial load 200 N max. **Fig. 88**

High stiffness concentric roller

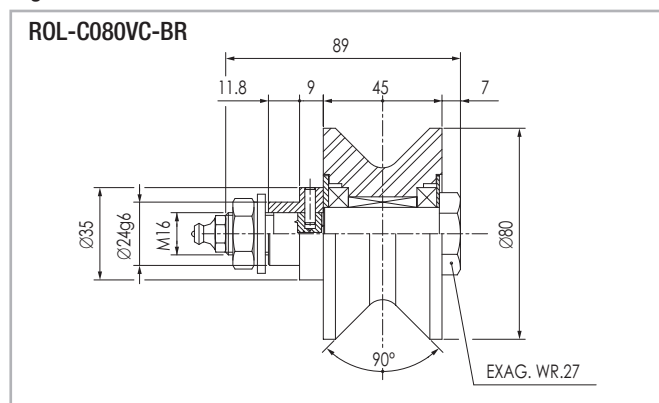

Radial load 1000 N max. axial load 400 N max. - Optional lifetime lubrication (end play 0.010/0.030 mm) **Fig. 89**

High stiffness eccentric roller

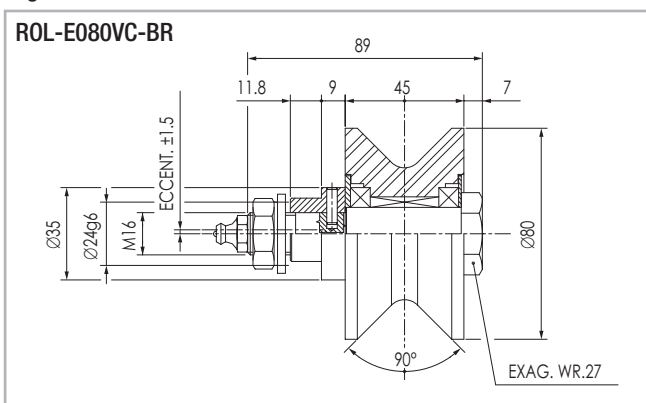

Radial load 1000 N max. axial load 400 N max. - Optional lifetime lubrication (end play 0.010/0.030 mm) **Fig. 90**

Concentric roller - axially free: ±1.9 mm

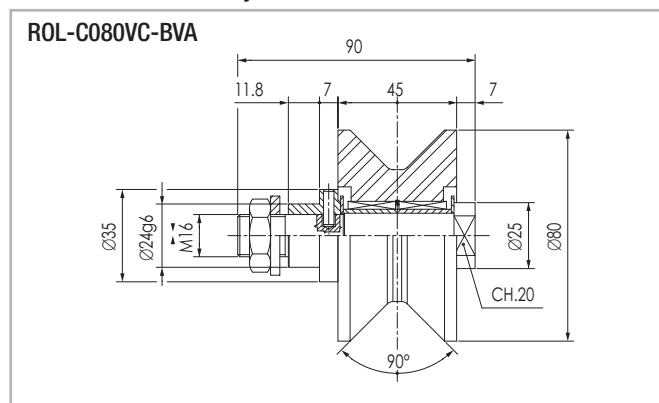

Radial load: 1000 N max. - lifetime lubrication **Fig. 91**

Eccentric roller - axially free: ±1.9 mm

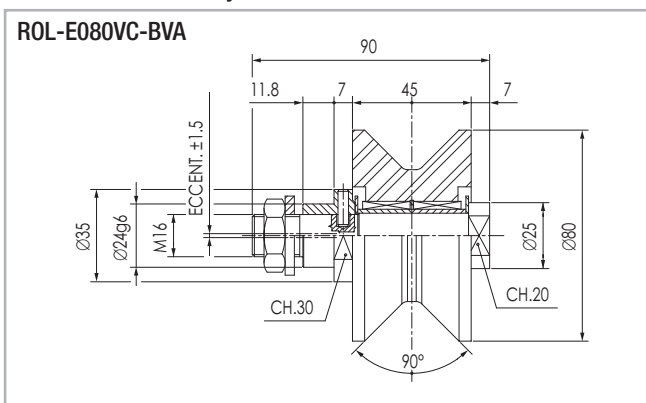

Radial load: 1000 N max. - lifetime lubrication **Fig. 92**

> Roller assembly with "V" rollers

Light weight roller assembly with 4 rollers

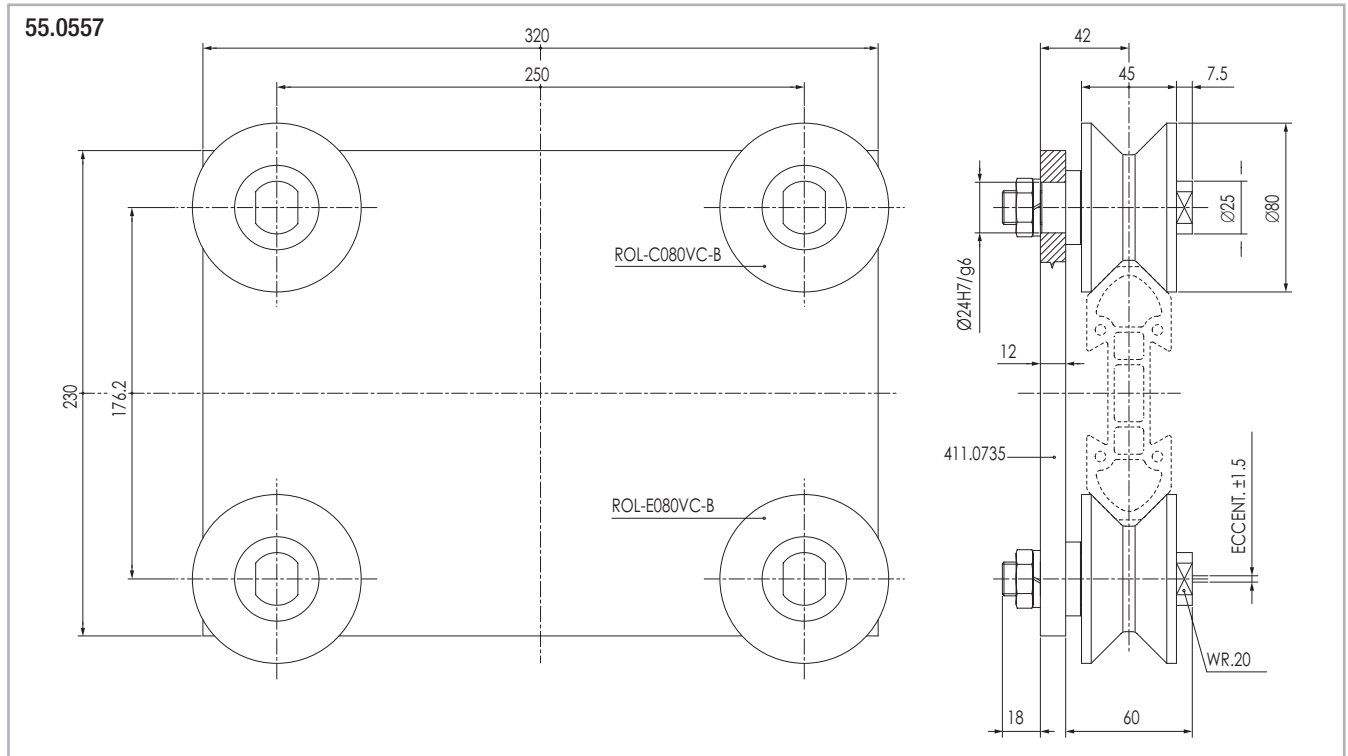

Fig. 93

Roller assembly with 4 high stiffness rollers

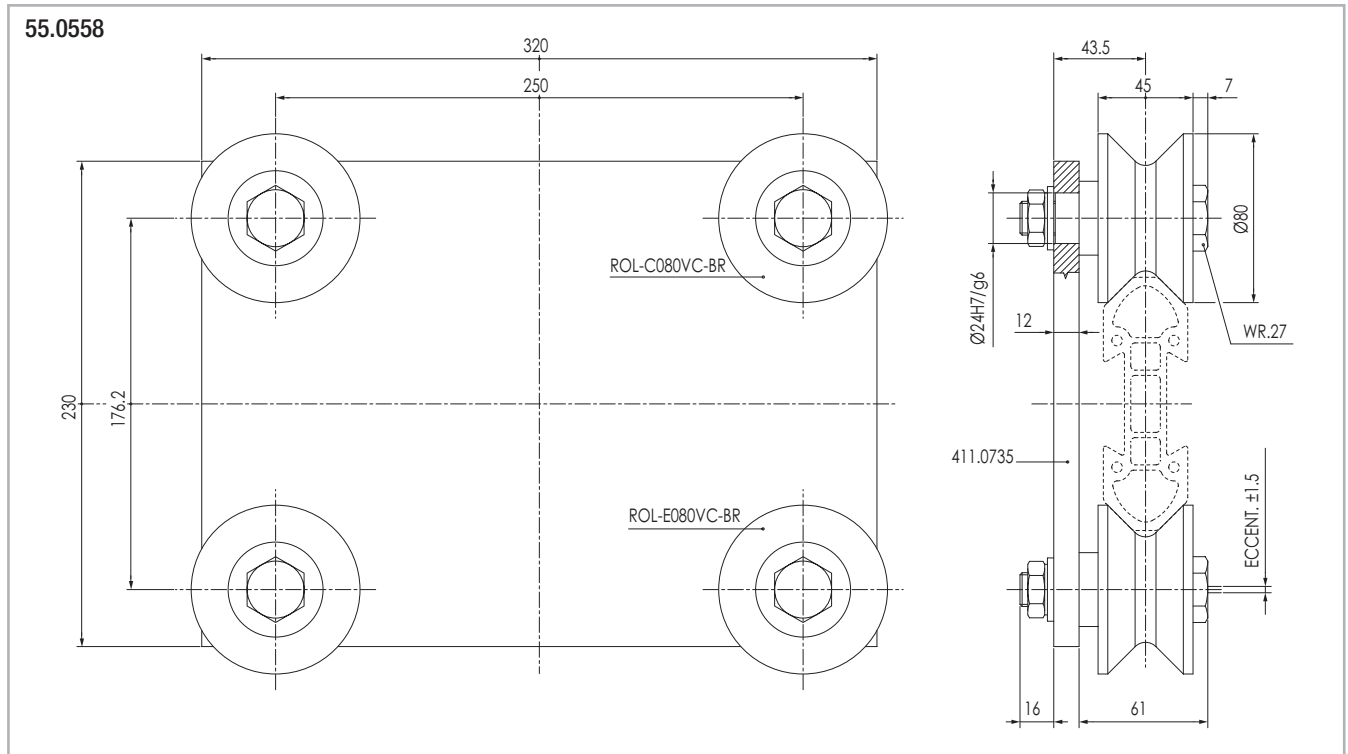

Fig. 94

The plate -cod. 411.0735 - is made in aluminium alloy with hard anodization. The rollers -cod. ROL-C080VC-BVA ROL-E080VC-BVA - and/or different combinations from the ones shown on this page can be mounted on the above plates after consulting our technical department.

> Plastic compound shell rollers

Concentric roller radial load: 1280 N max.
Lifetime lubrication

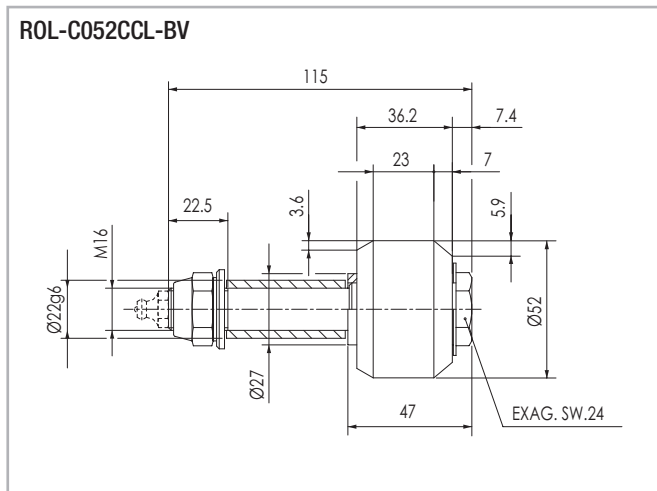

Fig. 95

Eccentric roller radial load: 1280 N max.
Lifetime lubrication

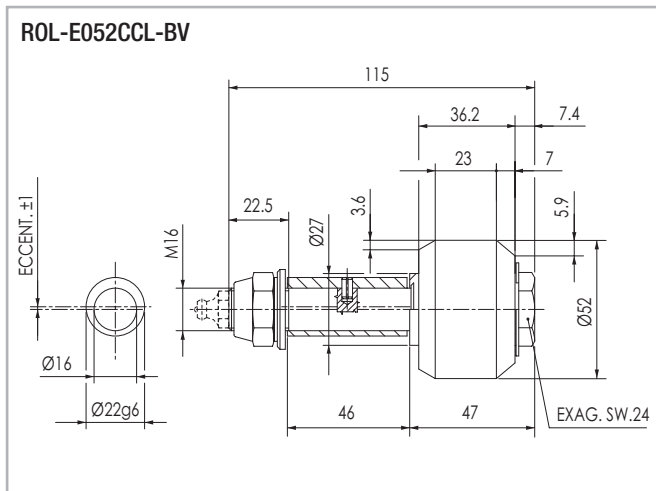

Fig. 96

Concentric roller radial load: 1280 N max. Periodical lubrication

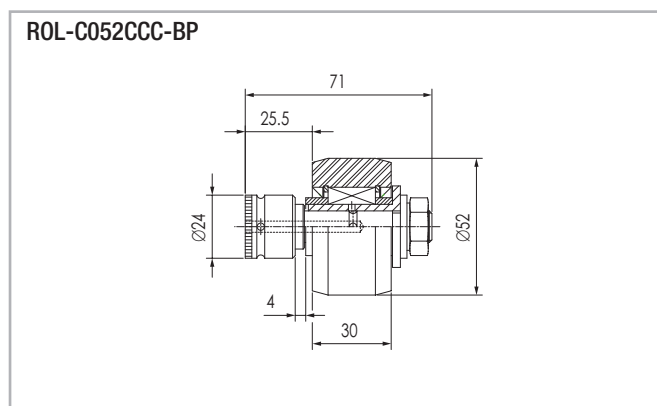

Fig. 97

Eccentric roller radial load: 1280 N max. Periodical lubrication

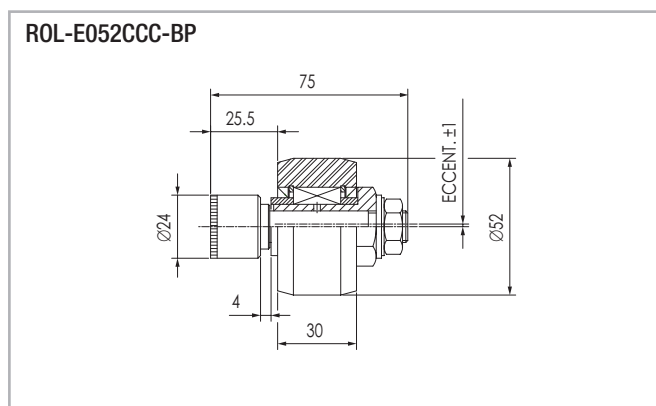

Fig. 98

Concentric roller radial load: 880 N max.
Periodical lubrication

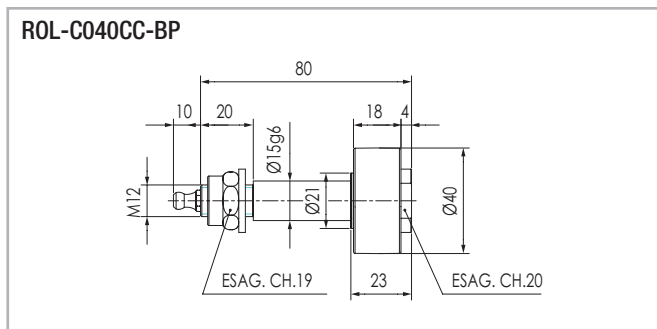

Fig. 99

Concentric roller radial load: 880 N max.
Lifetime lubrication

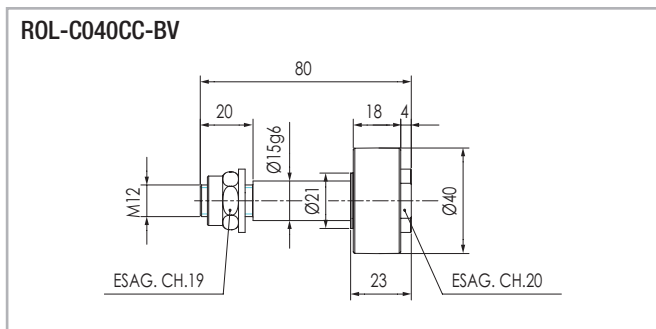
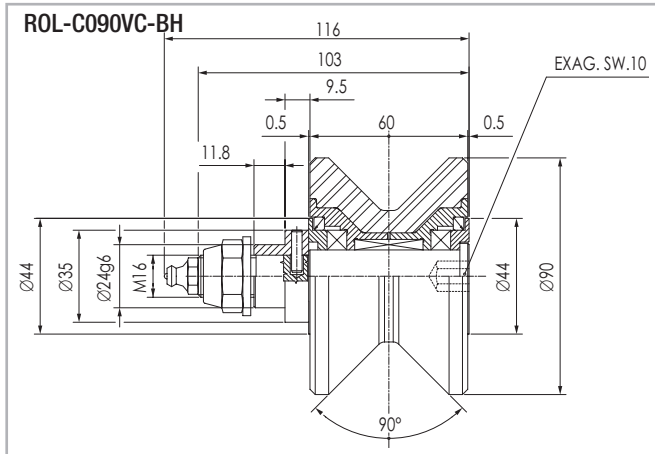

Fig. 100

Heavy duty concentric 'V' roller



Max. load: radial 1150 N axial 650 N

Fig. 101

Heavy duty eccentric 'V' roller

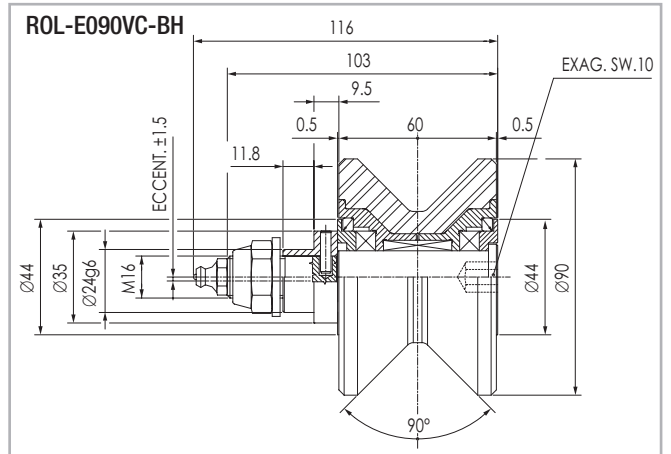

Max. load: radial 1150 N axial 650 N

Fig. 102

Heavy duty concentric 'V' roller - axially free: ±1.5 mm

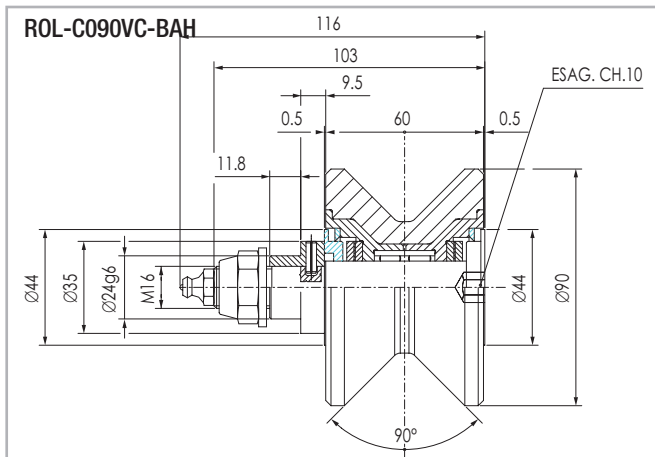

Radial load: 1150 N max.

Fig. 103

Heavy duty eccentric 'V' roller - axially free: ±1.5 mm

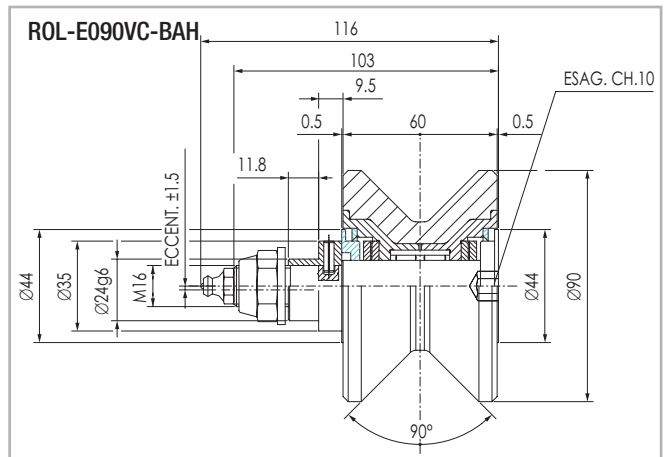

Radial load: 1150 N max.

Fig. 104

Protected concentric 'V' roller for heavy duties

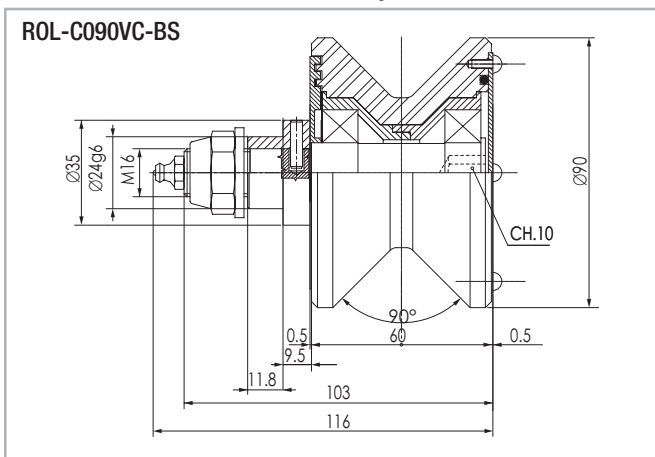

Max. load: radial 1150 N axial 650 N - Optional lifetime lubrication

Fig. 105

Protected eccentric 'V' roller for heavy duties

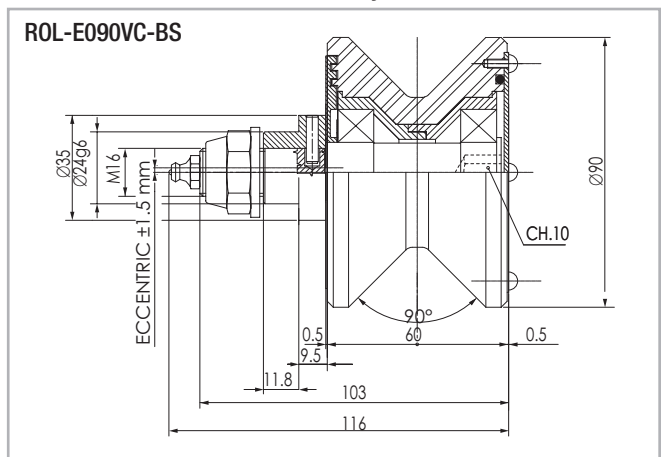

Max. load: radial 1150 N axial 650 N - Optional lifetime lubrication

Fig. 106

Wheelbase for all 'V' shaped rollers on Speedy Rail:

Wheelbase between roller centers for SR250 = 302,2 mm

Wheelbase between roller centers for SR180 = 232,2 mm

Wheelbase between roller centers for SR120 = 176,2 mm

> 2 Rollers light full-block assembly

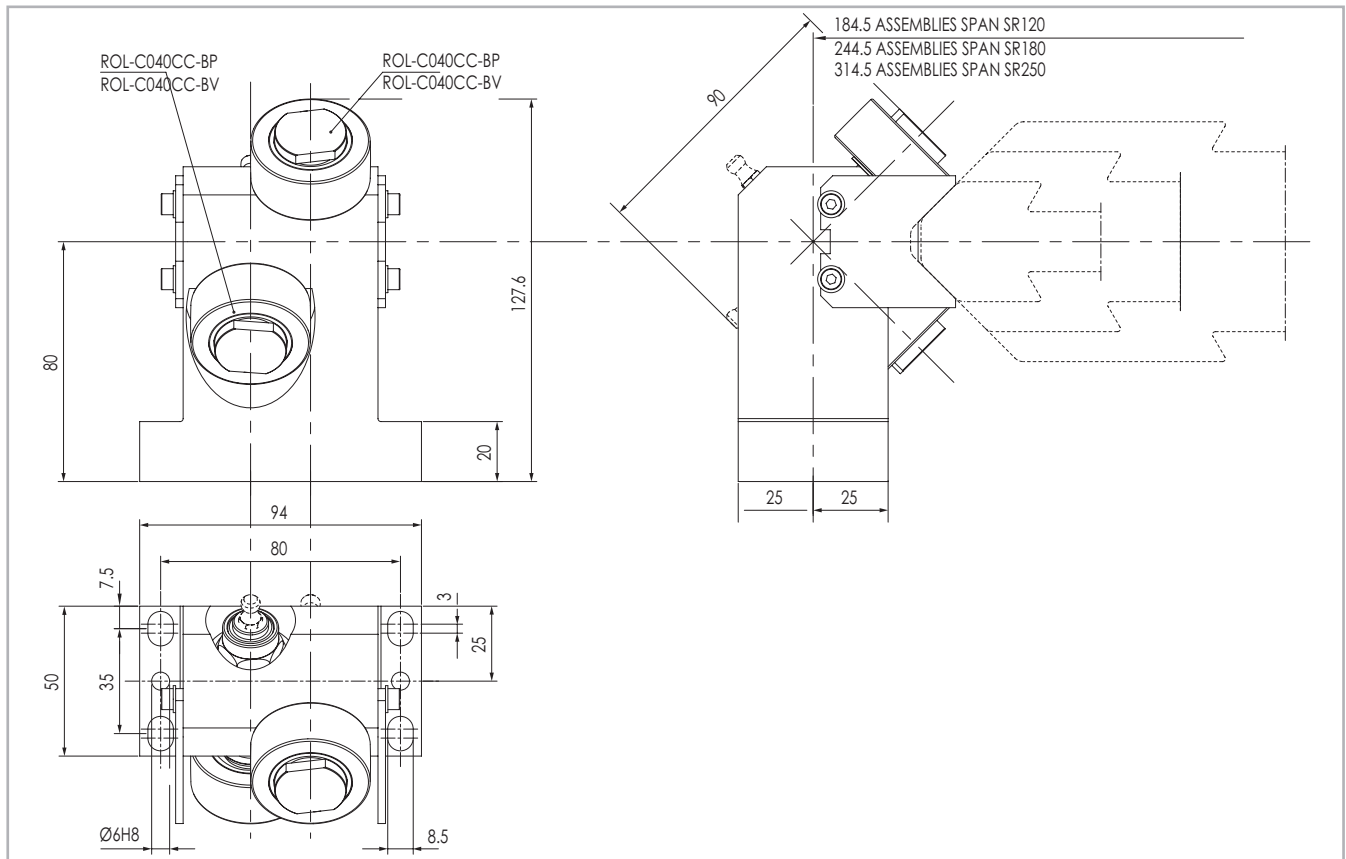

Fig. 107

55.1550
 Light alloy rollers assembly with 2 Ø40 rollers. ROL-C040CC-BP
 Periodical lubrication.

55.1570
 Light alloy rollers assembly with 2 Ø40 rollers, ROL-C040CC-BV
 Lifetime lubricated.

> Compact roller assembly with plastic compound rollers

Light alloy compact roller assembly periodical lubrication version

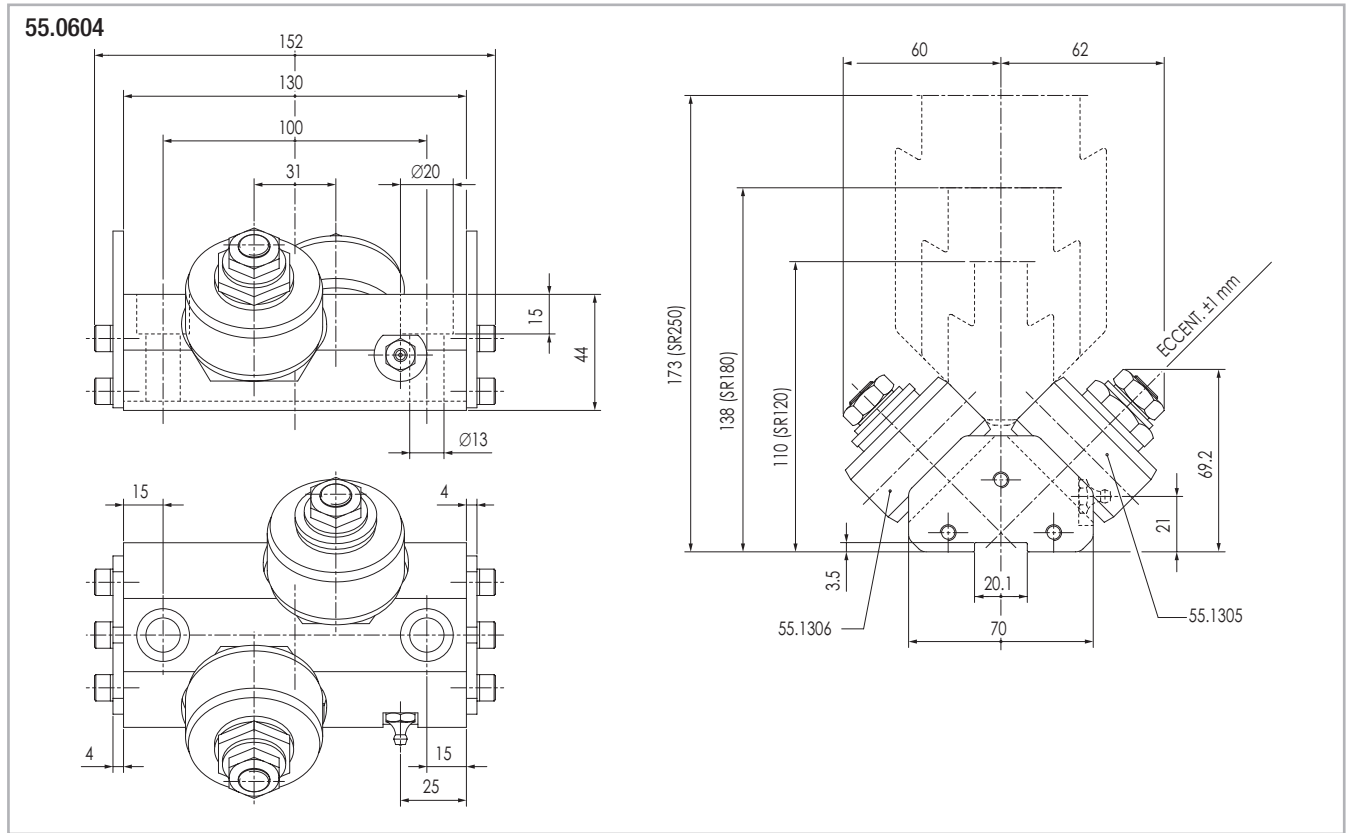

Fig. 108

Light alloy compact roller assembly lifetime lubrication version

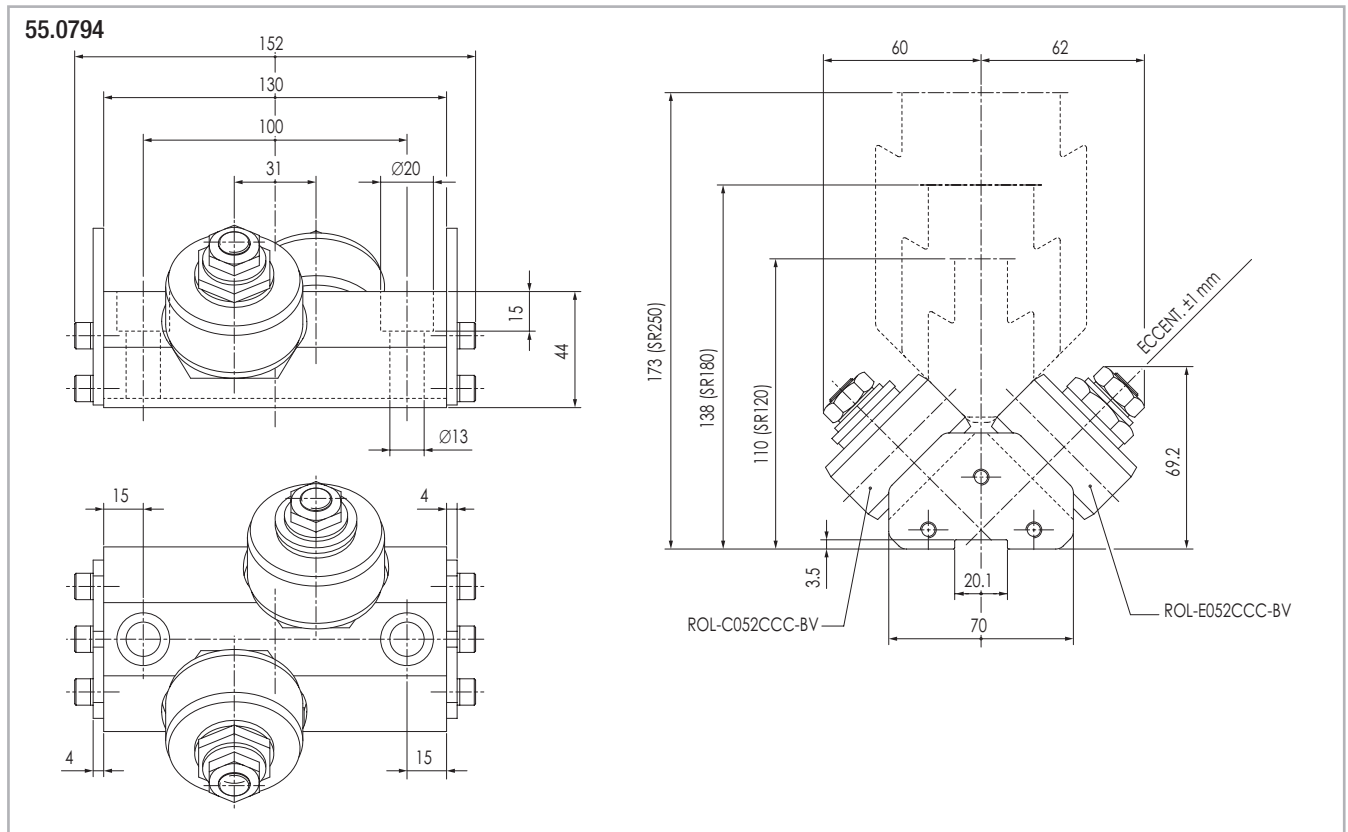

Fig. 109

S
R

> Full-block roller assembly

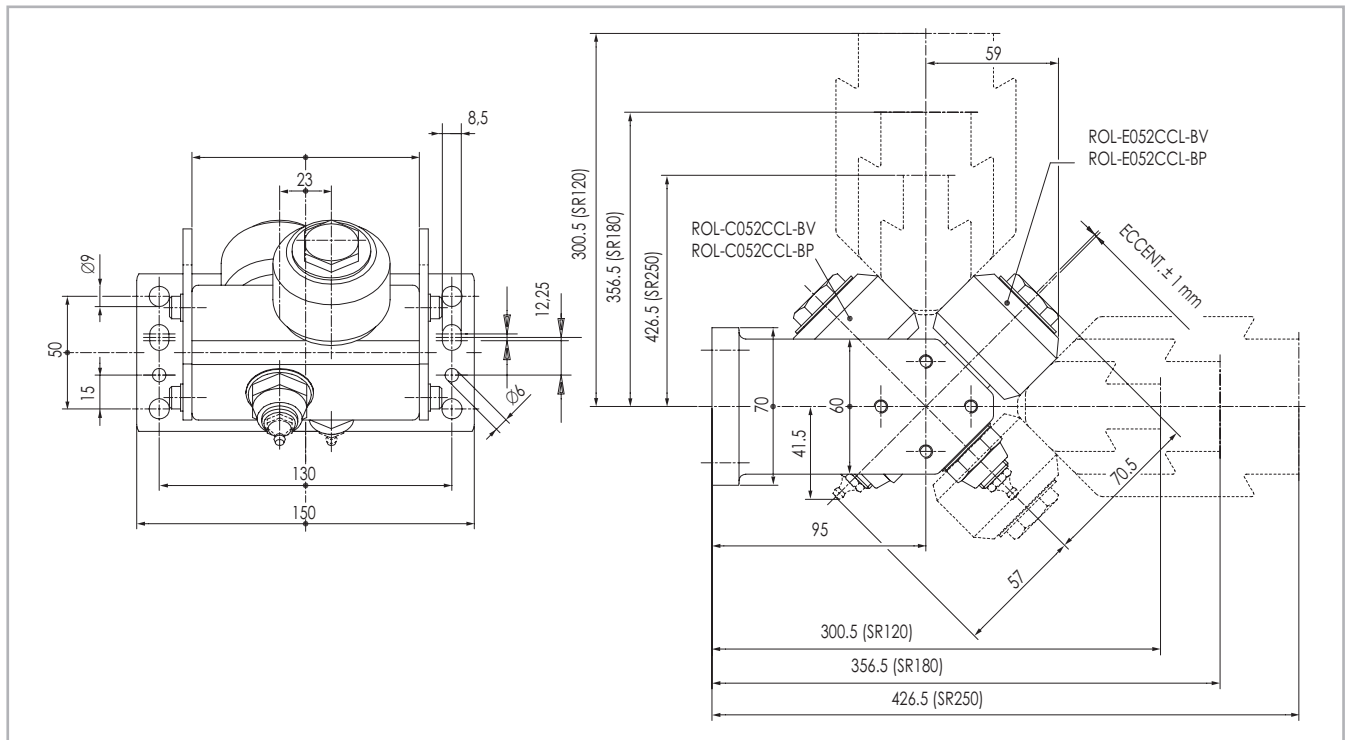

Fig. 110

55.0325

Light alloy body roller assembly with mounting holes on short sides and plastic compound rollers, periodical lubrication version, rollers ROL-C052CCL-BP, ROL-E052CCL-BP

55.0725

Lifetime lubrication version rollers ROL-C052CCL-BV, ROL-E052CCL-BV

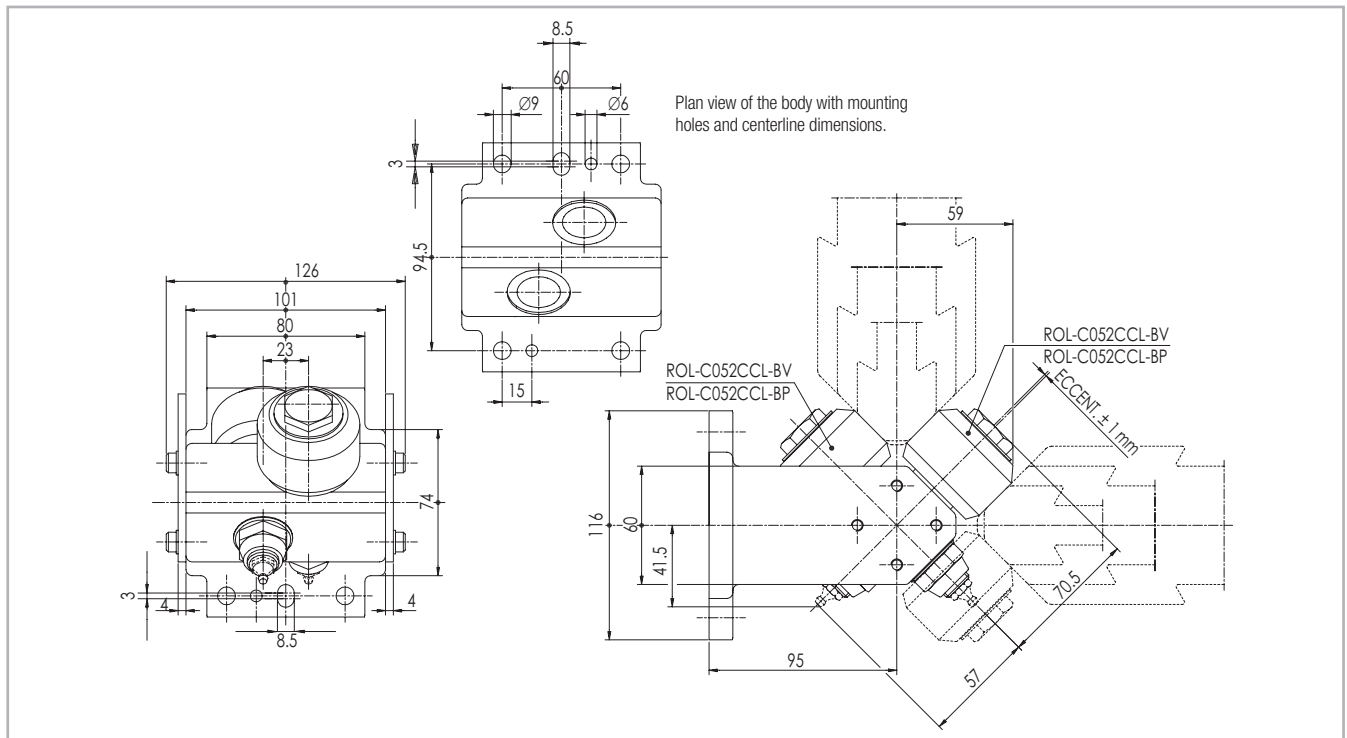

Fig. 111

55.0433

Light alloy body roller assembly with mounting holes on long sides and plastic compound rollers, periodical lubrication version, rollers ROL-C052CCL-BP, ROL-E052CCL-BP

55.0733

Lifetime lubrication version rollers ROL-C052CCL-BV, ROL-E052CCL-BV

> Roller assembly with 4 rollers

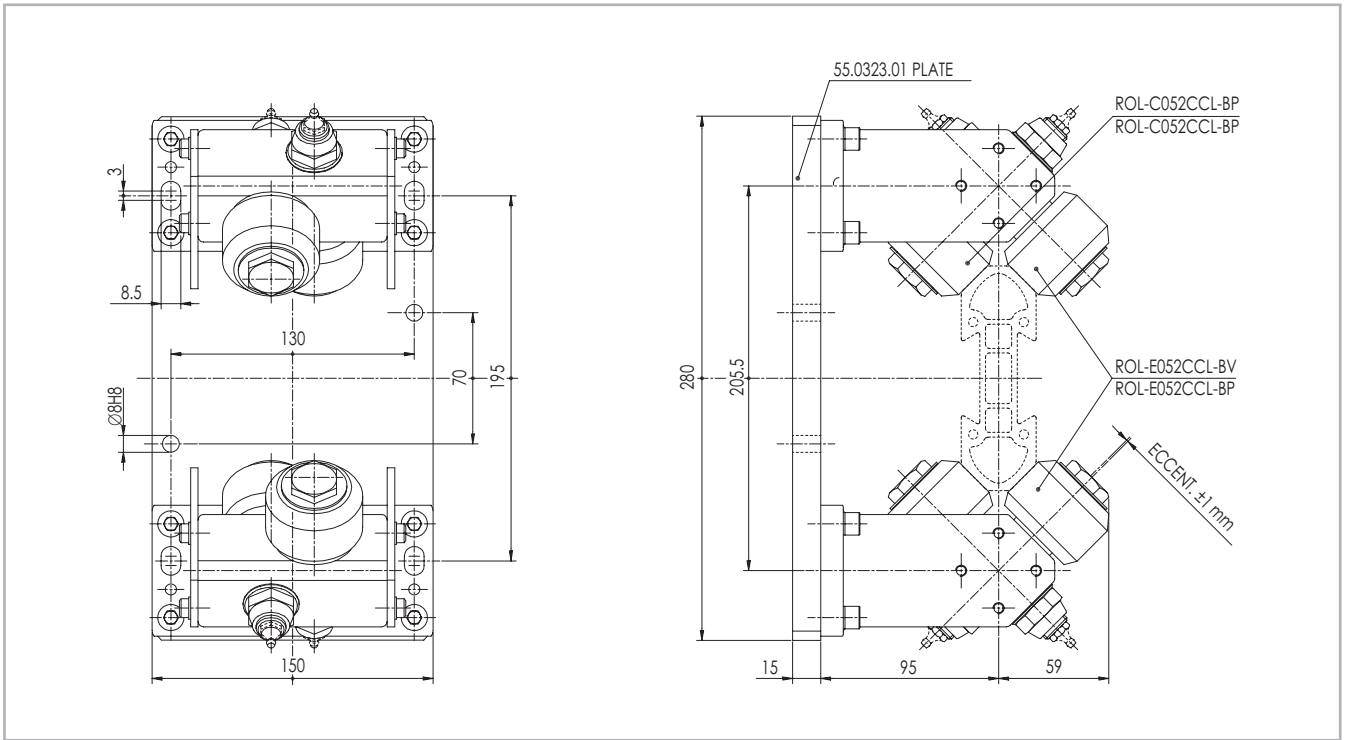

Fig. 112

55.0323

Roller assembly with backing plate 280x150x15. Rollers ROL-C052CCL-BP, ROL-E052CCL-BP with periodical lubrication

55.0723

Roller assembly with backing plate 280x150x15. Rollers ROL-C052CCL-BV, ROL-E052CCL-BV, lifetime lubricated

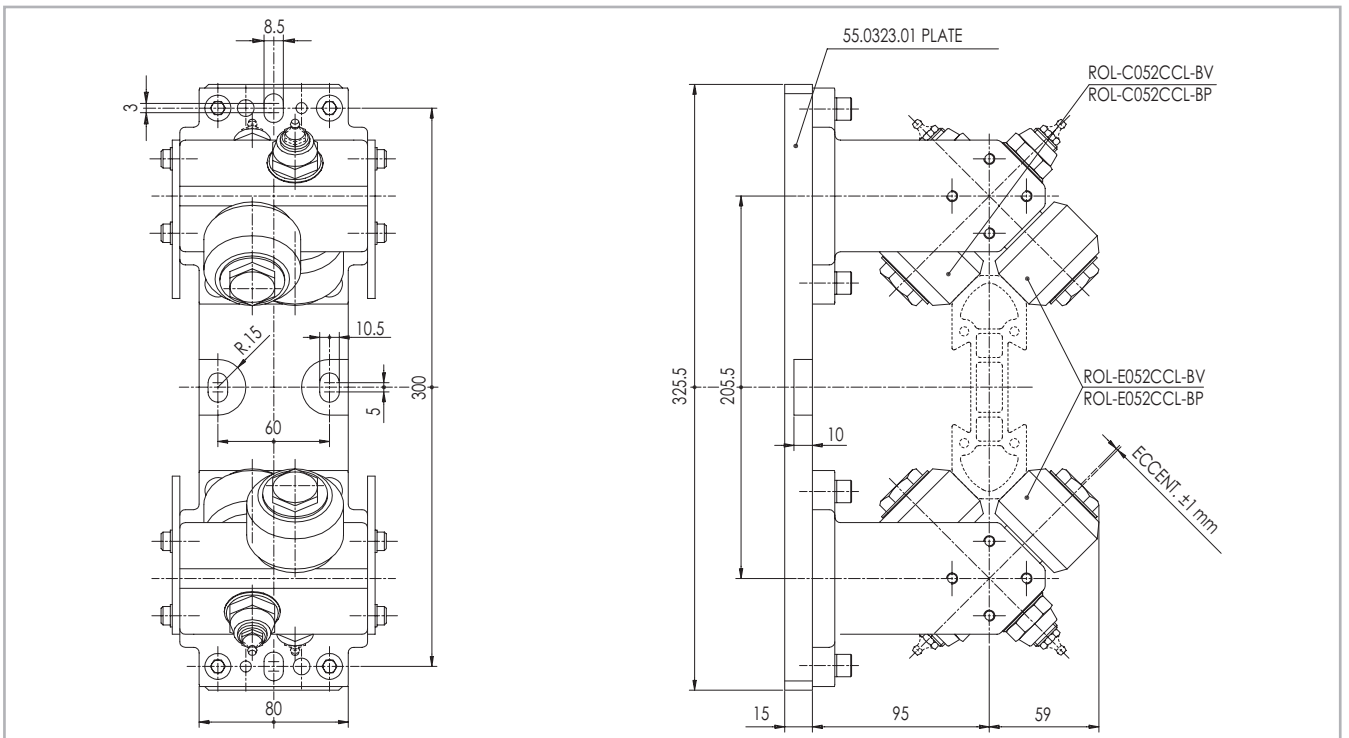

Fig. 113

55.0324

Roller assembly with backing plate 235.5x80x15. Rollers ROL-C052CCL-BP, ROL-E052CCL-BP with periodical lubrication

55.0724

Roller assembly with backing plate 235.5x80x15. Rollers ROL-C052CCL-BV, ROL-E052CCL-BV lifetime lubricated

> **Narrow/wide base blindo beam roller assembly**

Narrow base roller assembly

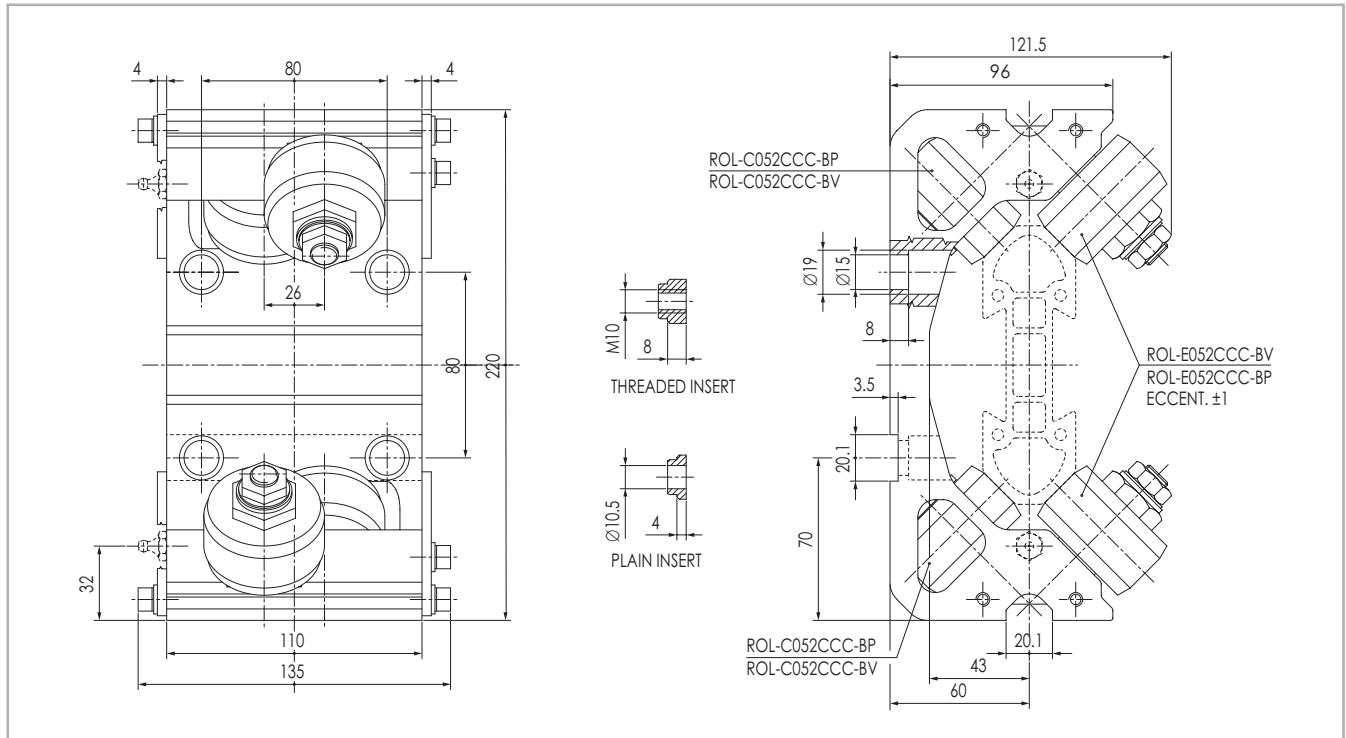

Fig. 114

55.0472-FIL

Equipped with 4 threaded fixing inserts
Periodical lubrication

55.0472-PAS

Equipped with 4 through hole fixing inserts
Periodical lubrication

55.0772-FIL

Equipped with 4 threaded fixing inserts
Lifetime lubrication

55.0772-PAS

Equipped with 4 through hole fixing inserts
Lifetime lubrication

Wide base roller assembly

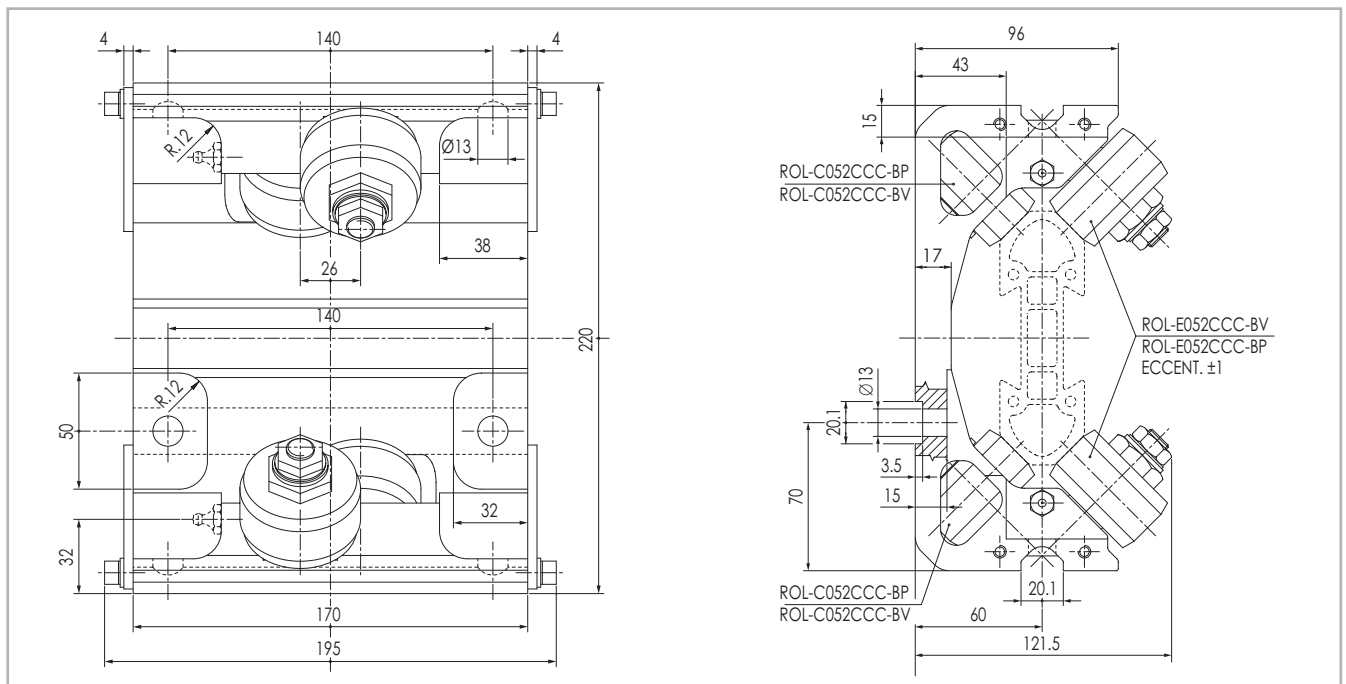

Fig. 115

55.0411

Periodical lubrication

SR-42

55.0711

Lifetime lubrication

> 8 Rollers blindo beam roller assembly

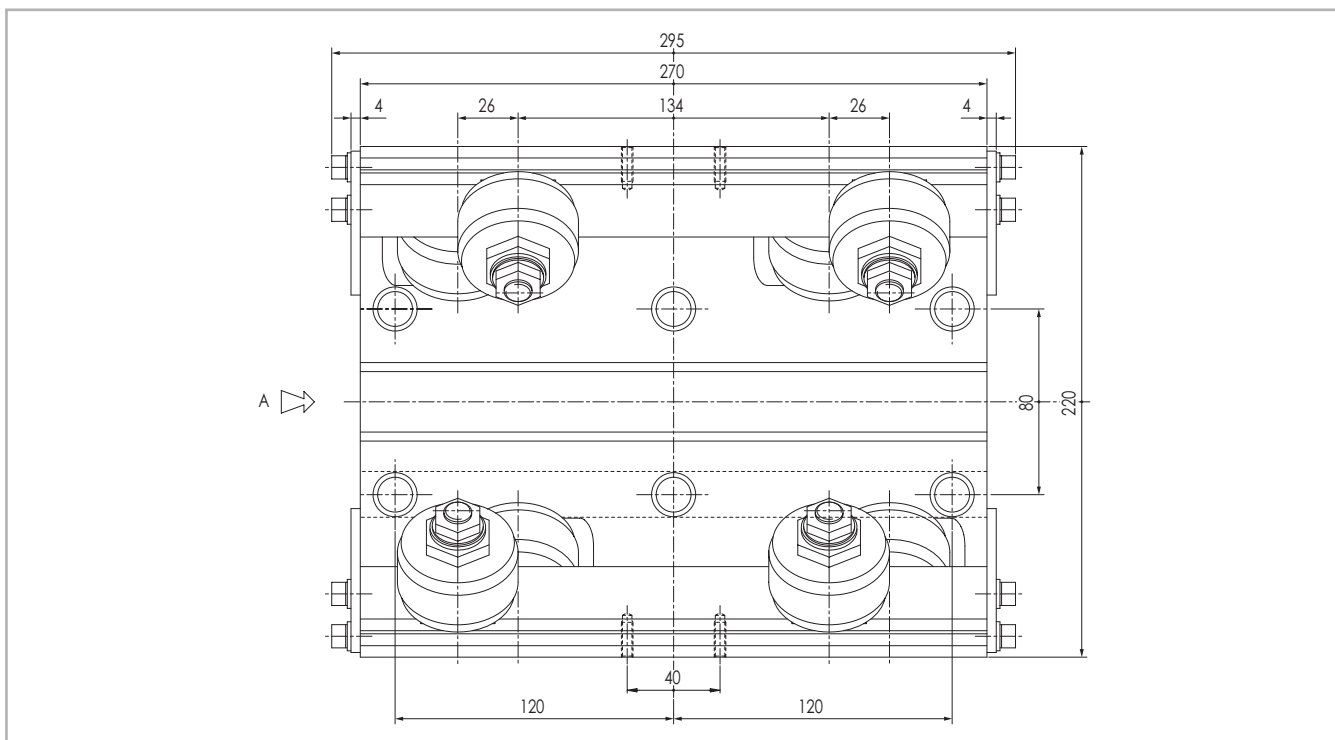

Fig. 116

55.0222-FIL

Equipped with 6 threaded fixing inserts
Lifetime lubrication

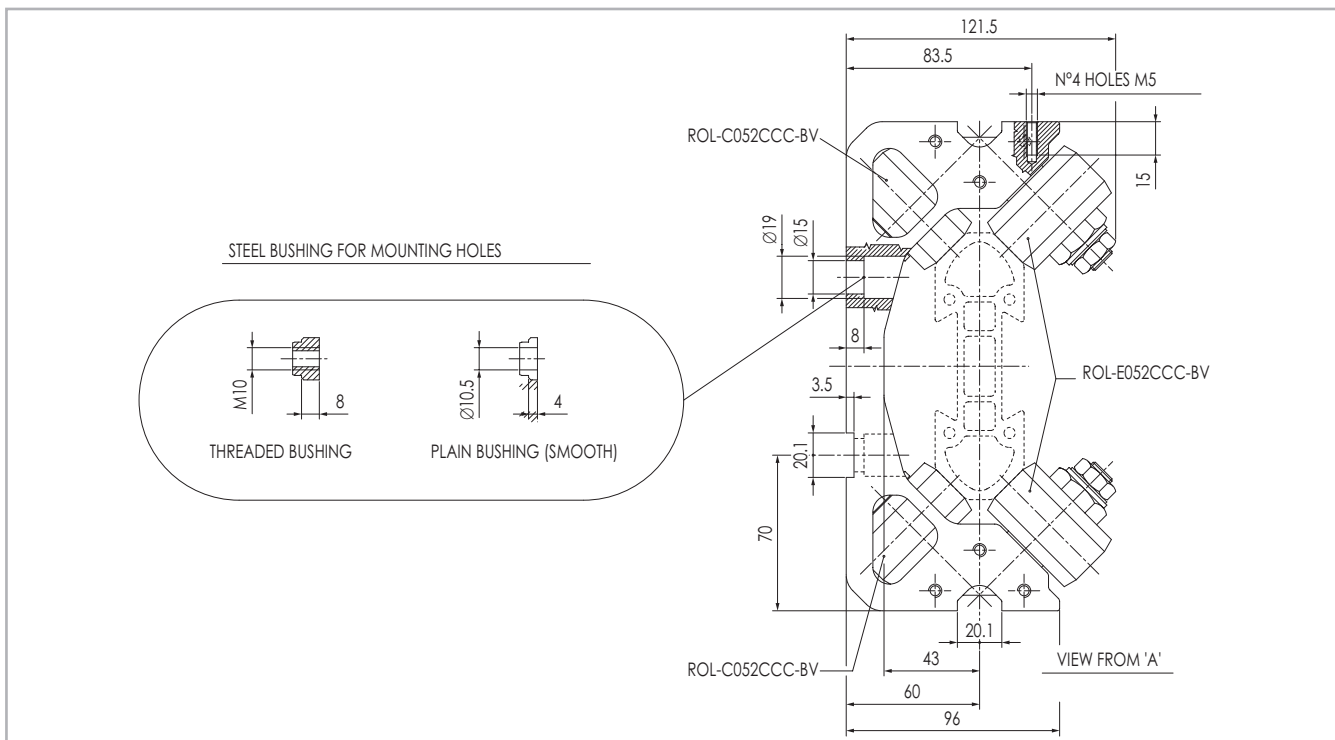

Fig. 117

55.0222-PAS

Equipped with 6 through hole fixing inserts
Lifetime lubrication

S
R

> Light 4 rollers floating assembly for Speedy Rail guides

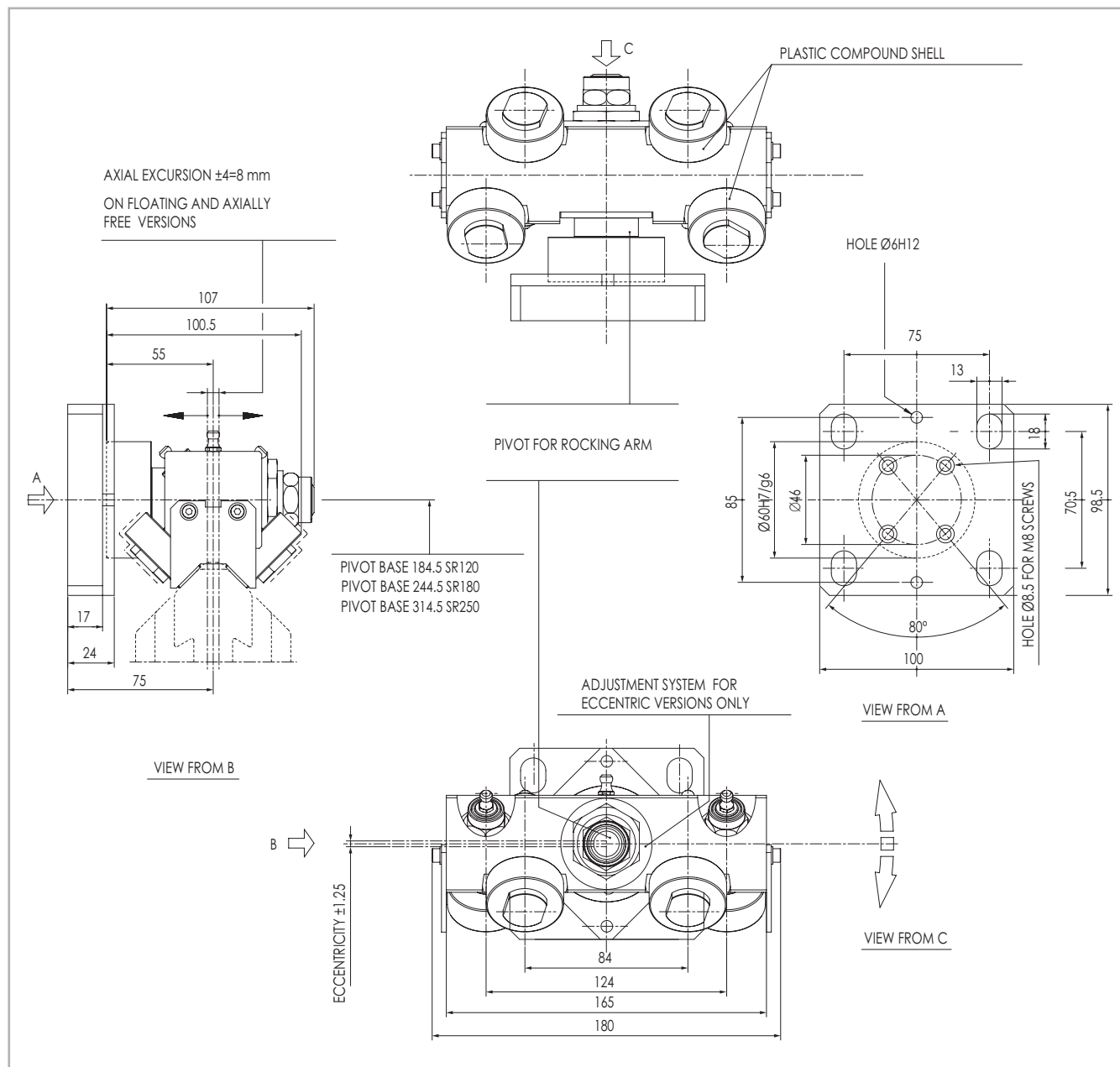

* Lubrication nipple mounted for periodic lubrication versions only

Fig. 118

Assemblies without baseplate have the same code followed by "SP"
(i.e. 55.1361/SP)

Roller assemblies reference		Axially constrained	Axially free	Rollers code
PERIODICAL LUBRICATION	ECC.	55.1565	55.3563	ROL-C040CC-BP
	CONC.	55.1566	55.3564	
LIFETIME LUBRICATION	ECC.	55.1555	55.3553	ROL-C040CC-BV
	CONC.	55.1556	55.3554	

Tab. 12

> Floating roller assembly with 4 rollers - short/long pivot

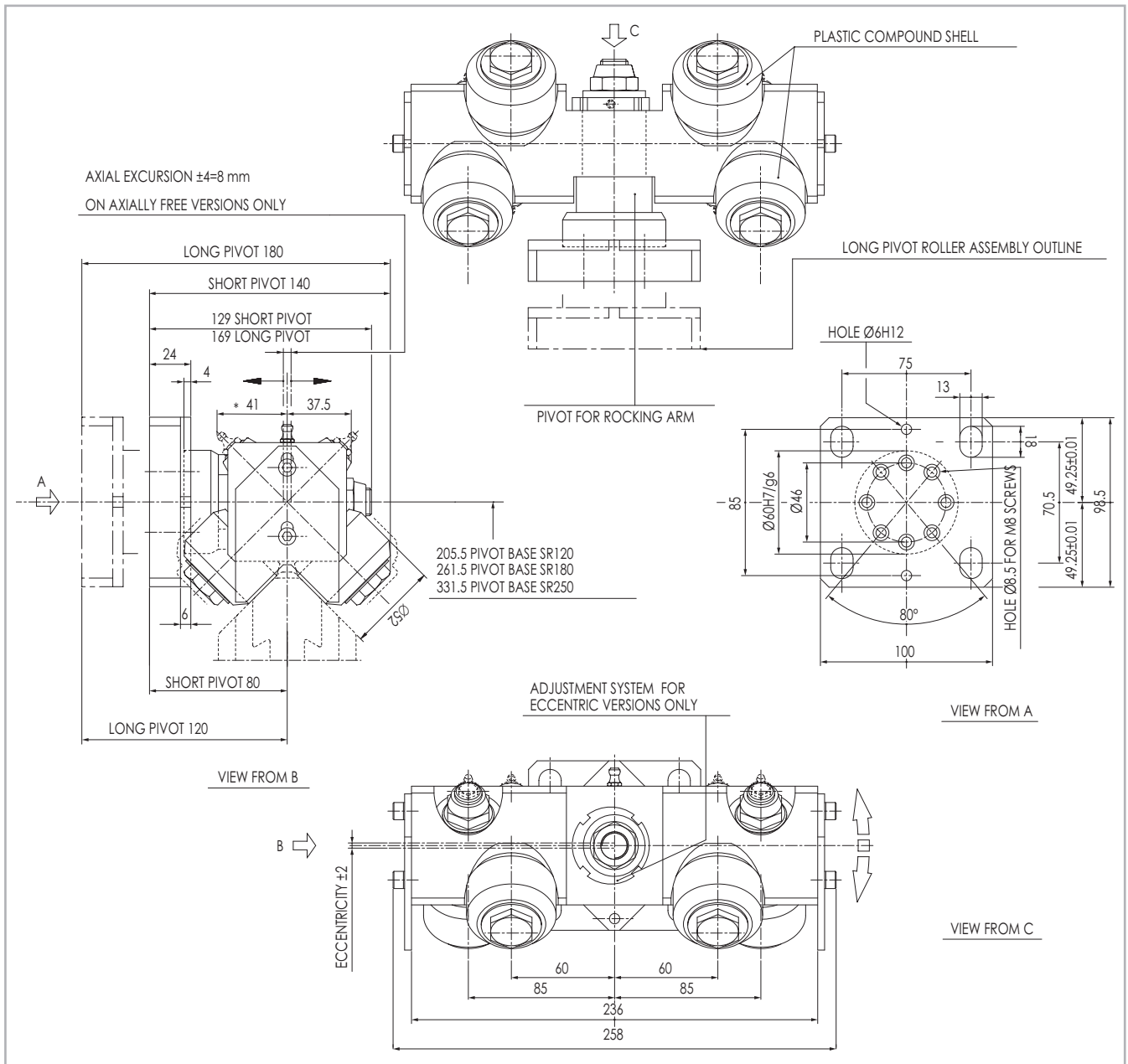

* Lubrication nipple mounted for periodic lubrication versions only

Fig. 119

Notes:

The axially free version of the assemblies are normally mounted on trolleys running on parallel rails. Coupled with axially constrained assemblies provide a flexible structure able to withstand minor misalignments between runways.

Assemblies without baseplate have the same code followed by "SP" (ad es. 55.1361/SP).

Roller assemblies reference			Axially constrained	Axially free	Rollers code
Short pivot	PERIODICAL LUBRICATION	ECC.	55.1361	55.3361	ROL-C052C-CL-BP
		CONC.	55.1364	55.3364	
	LIFETIME LUBRICATION	ECC.	55.1354	55.1358	ROL-C052C-CL-BV
		CONC.	55.1355	55.1359	
Long pivot	PERIODICAL LUBRICATION	ECC.	55.1363	55.3363	ROL-C052C-CL-BP
		CONC.	55.1365	55.3365	
	LIFETIME LUBRICATION	ECC.	55.1350	55.3350	ROL-C052C-CL-BV
		CONC.	55.1351	55.3351	

Tab. 13

> 5 Rollers assembly, one fixed, one self adjusting

Fixed 5 concentric rollers assembly

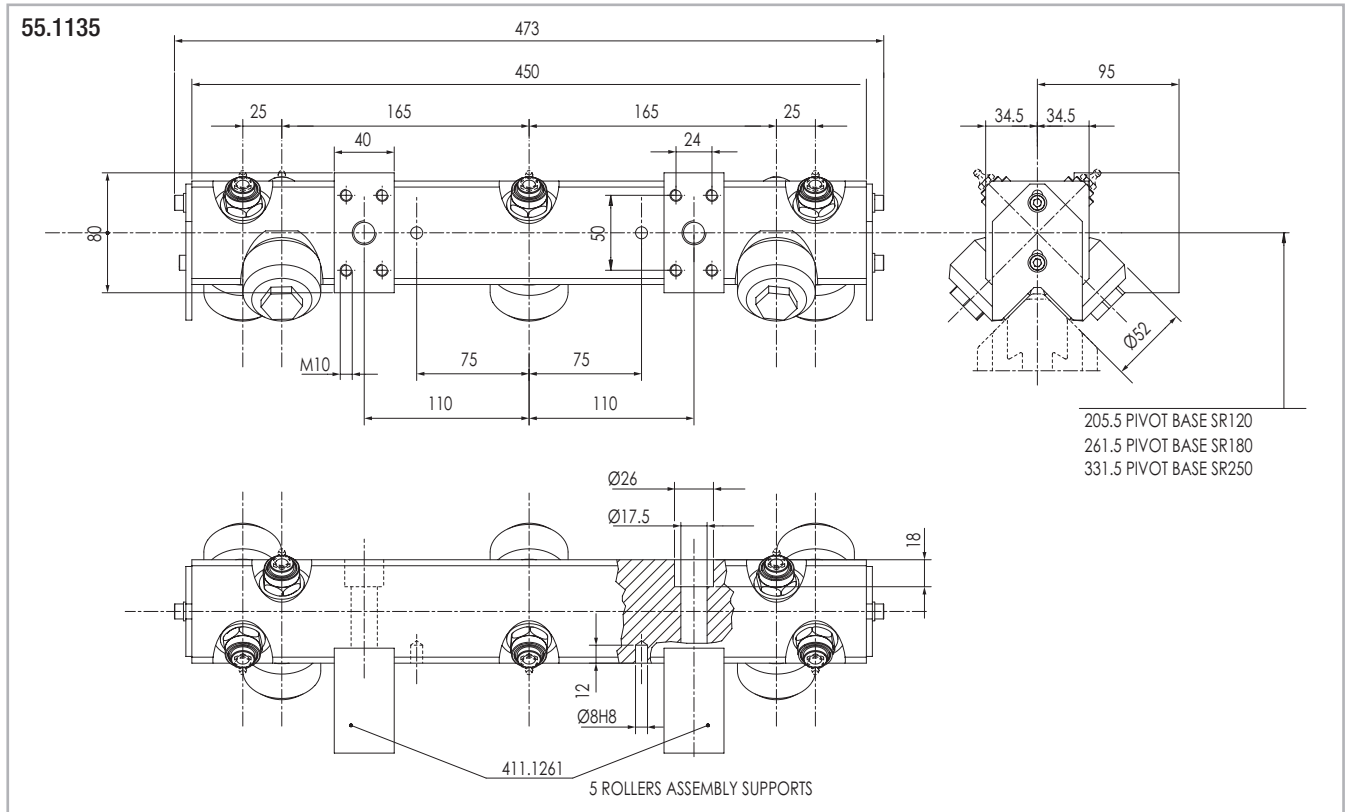

Fig. 120

Fixed 5 roller assembly, with 2 eccentric rollers for auto backlash retrieval

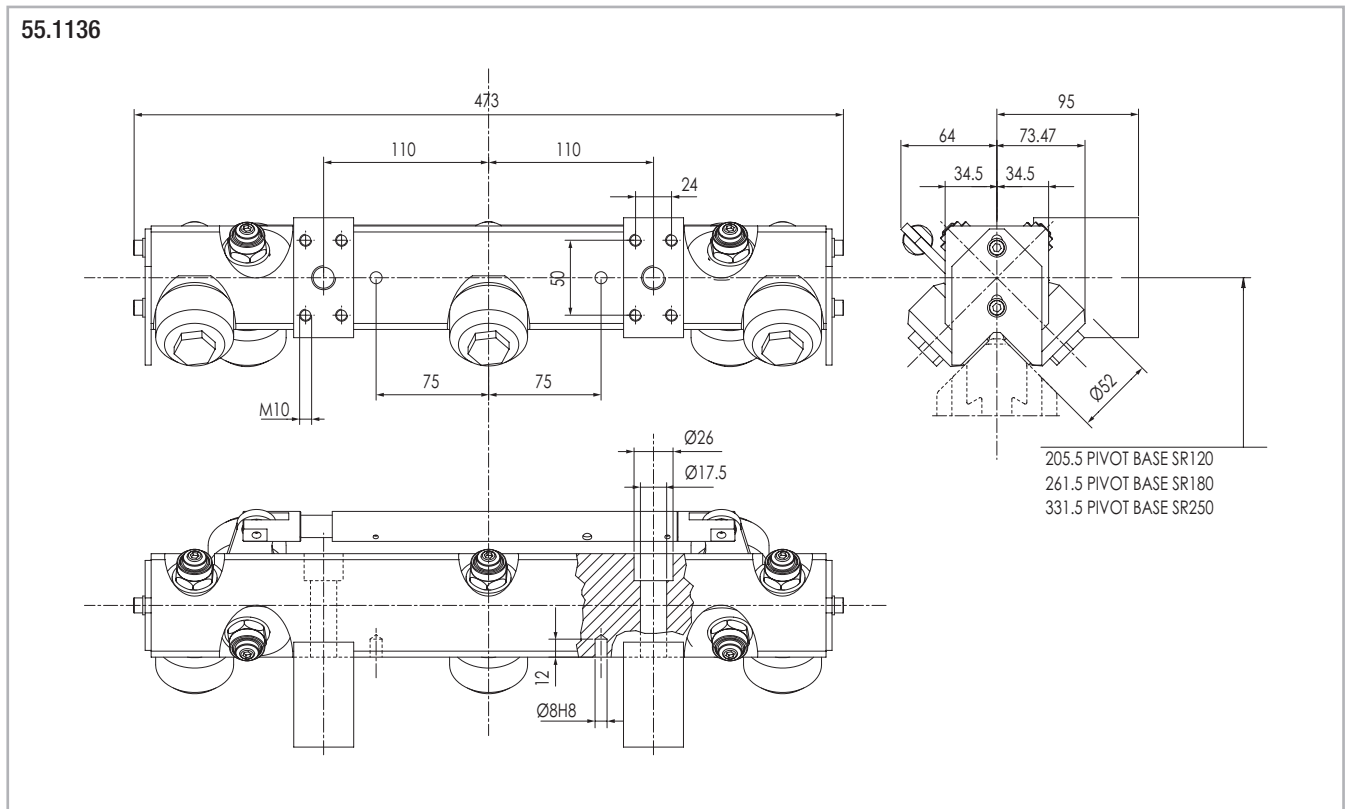
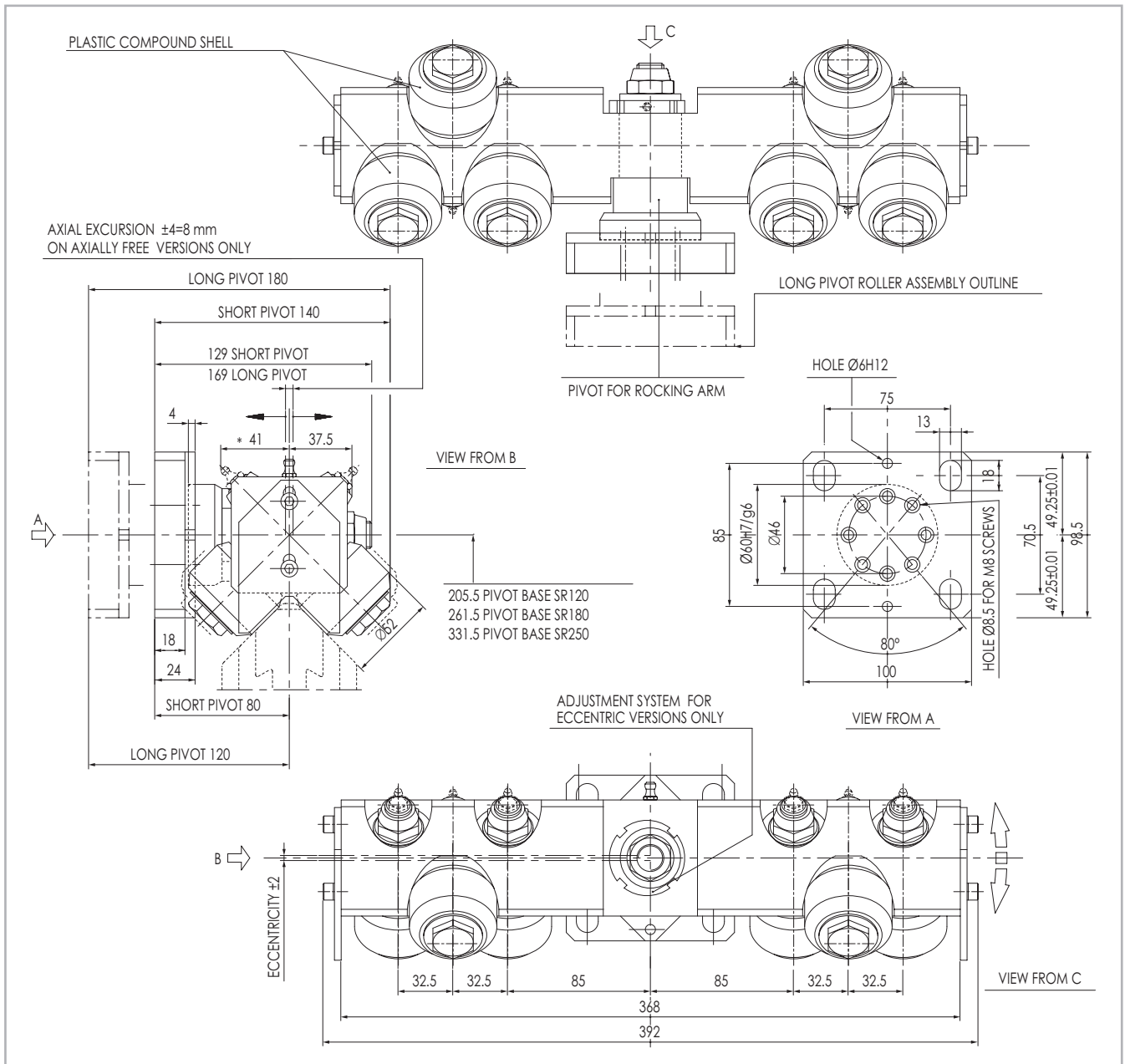

Fig. 121

> Floating roller assembly with 6 rollers - short/long pivot



* Lubrication nipple mounted for periodic lubrication versions only

Fig. 122

Notes:

The axially free version of the assemblies are normally mounted on trolleys running on parallel rails. Coupled with axially constrained assemblies provide a flexible structure able to withstand minor misalignments between runways.

Assemblies without baseplate have the same code followed by "SP" (i.e. 55.1366/SP).

Roller assemblies reference		Axially constrained	Axially free	Rollers code	
Short pivot	PERIODICAL LUBRICATION	ECC.	55.1423	55.3423	ROL-C052CCL-BP
		CONC.	55.1424	55.3424	
	LIFETIME LUBRICATION	ECC.	55.1425	55.3425	ROL-C052CCL-BV
		CONC.	55.1426	55.3426	
Long pivot	PERIODICAL LUBRICATION	ECC.	55.1419	55.3419	ROL-C052CCL-BP
		CONC.	55.1420	55.3420	
	LIFETIME LUBRICATION	ECC.	55.1421	55.3421	ROL-C052CCL-BV
		CONC.	55.1422	55.3422	

Tab. 14

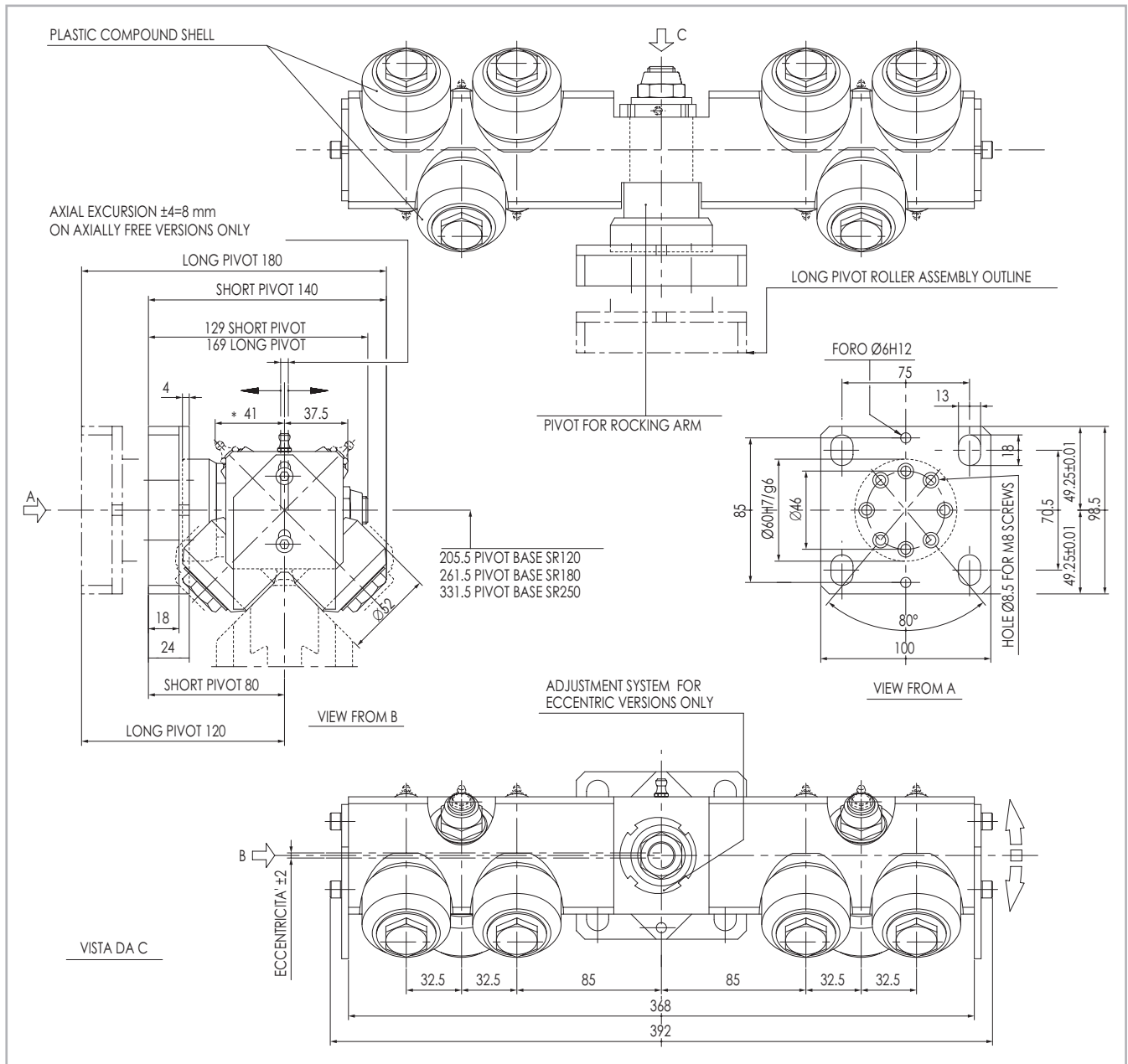

* Lubrication nipple mounted for periodic lubrication versions only

Fig. 123

Notes:

The axially free version of the assemblies are normally mounted on trolleys running on parallel rails. Coupled with axially constrained assemblies provide a flexible structure able to withstand minor misalignments between runways.

Assemblies without baseplate have the same code followed by "SP" (i.e. 55.1366/SP)

Roller assemblies reference			Axially constrained	Axially free	Rollers code
Short pivot	PERIODICAL LUBRICATION	ECC.	55.1366	55.3366	ROL-C052CCL-BP
		CONC.	55.1370	55.3370	
	LIFETIME LUBRICATION	ECC.	55.1367	55.3367	ROL-C052CCL-BV
		CONC.	55.1371	55.3371	
Long pivot	PERIODICAL LUBRICATION	ECC.	55.1368	55.3368	ROL-C052CCL-BP
		CONC.	55.1372	55.3372	
	LIFETIME LUBRICATION	ECC.	55.1369	55.3369	ROL-C052CCL-BV
		CONC.	55.1373	55.3373	

Tab. 15

> Floating roller assembly with 8 rollers - short/long pivot

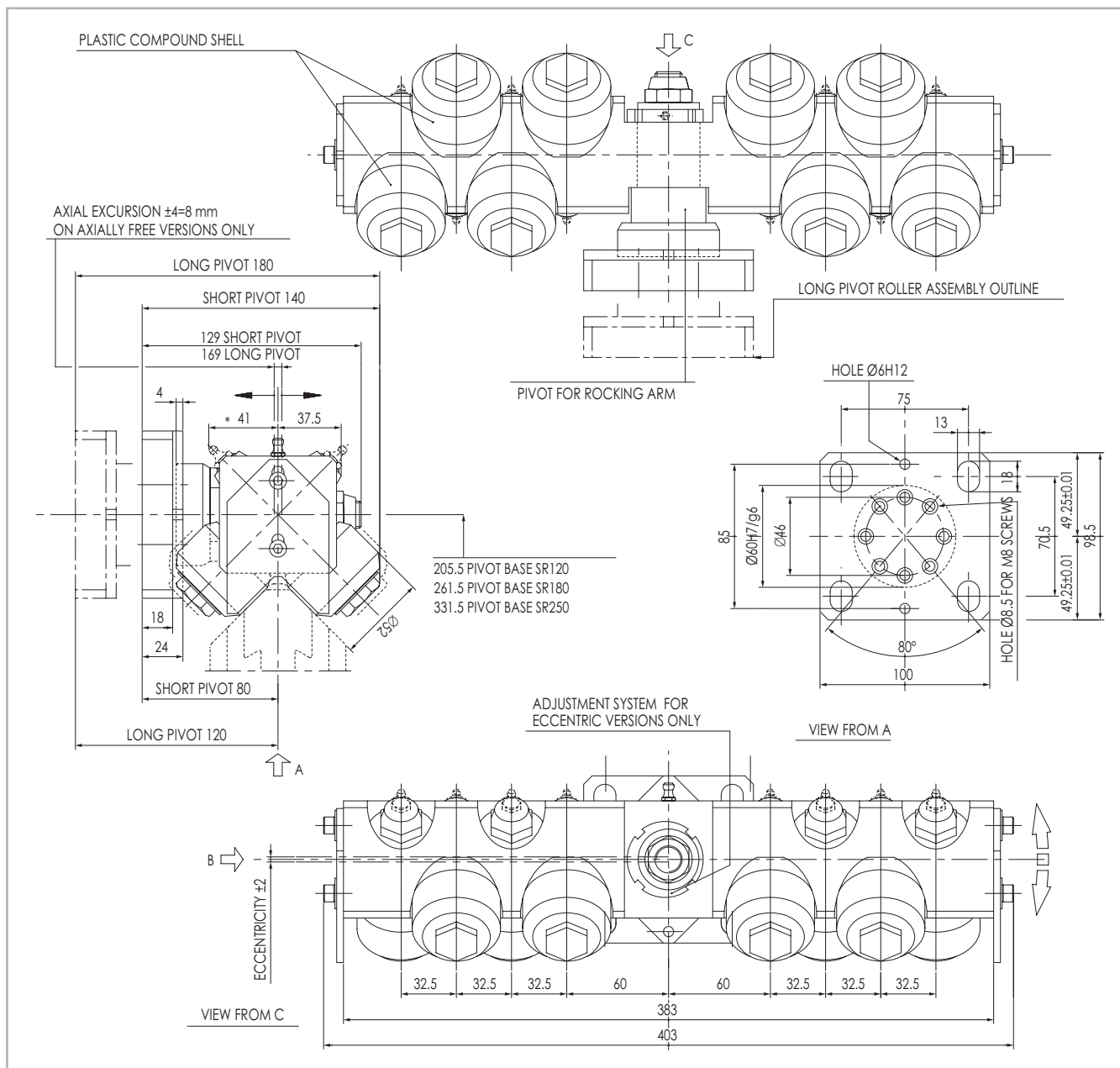

* Lubrication nipple mounted for periodic lubrication versions only

Fig. 124

Notes:

The axially free version of the assemblies are normally mounted on trolleys running on parallel rails. Coupled with axially constrained assemblies provide a flexible structure able to withstand minor misalignments between runways.

Assemblies without baseplate have the same code followed by "SP" (i.e. 55.1366/SP).

Roller assemblies reference			Axially constrained	Axially free	Rollers code
Short pivot	PERIODICAL LUBRICATION	ECC.	55.1143	55.3143	ROL-C052CCL-BV
		CONC.	55.1144	55.3144	
	LIFETIME LUBRICATION	ECC.	55.1145	55.3145	ROL-C052CCL-BV
		CONC.	55.1146	55.3146	
Long pivot	PERIODICAL LUBRICATION	ECC.	55.1147	55.3147	ROL-C052CCL-BP
		CONC.	55.1148	55.3148	
	LIFETIME LUBRICATION	ECC.	55.1149	55.3149	ROL-C052CCL-BV
		CONC.	55.1150	55.3150	

Tab. 16

> Assembling diagram for rigid mounted rack

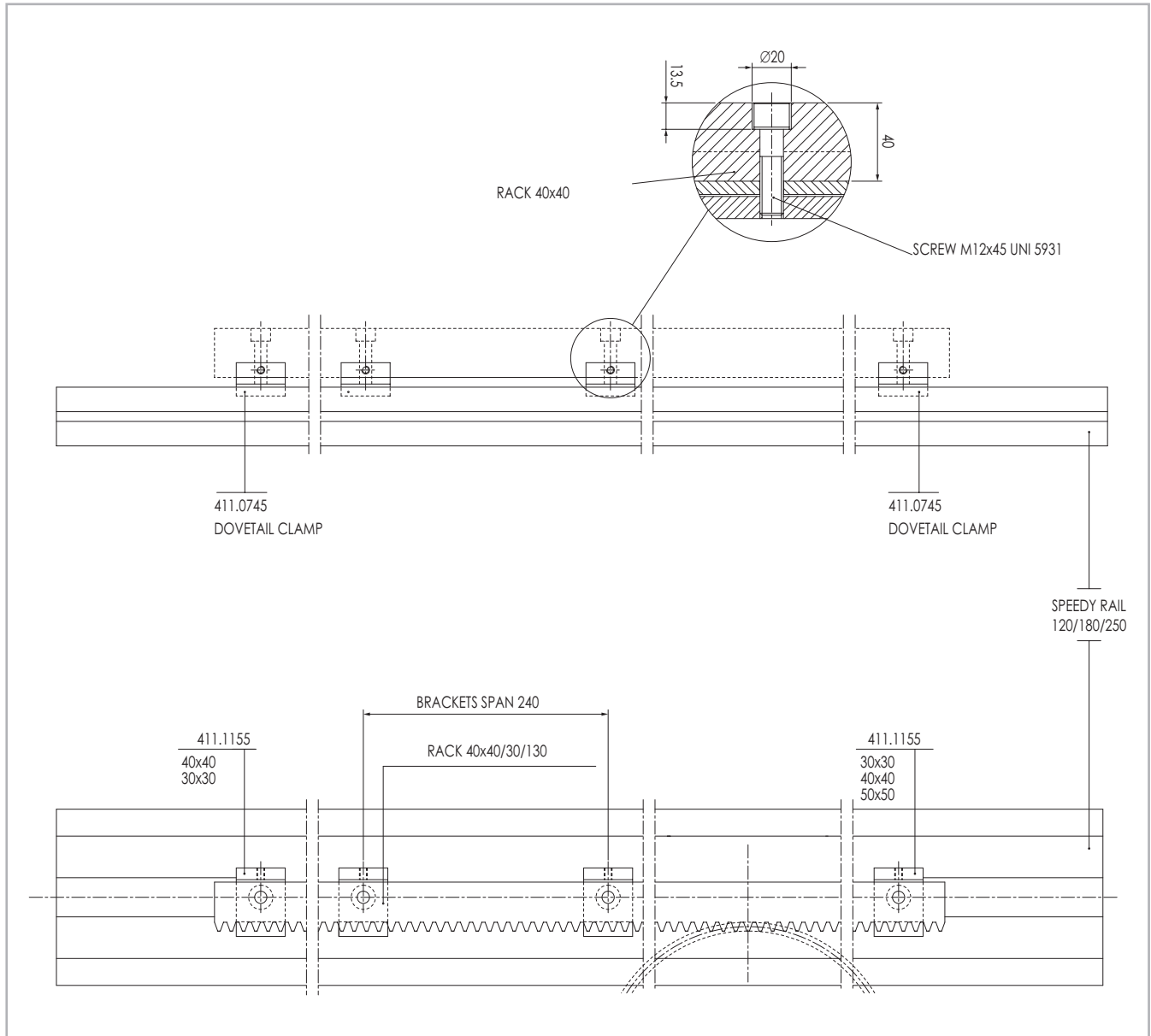

Fig. 125

> Standard racks

Straight toothed hardened rack

Cod.	C	D	d	E	F	H	L	N	P	Mod.
411.1489	10	11	7	19,41	7	20	998,82	5	240	2
411.1491	10	11	7	42,07	7	20	2004,14	9	240	2
411.1499	17	14	9	19,41	9	30	998,82	5	240	3
411.1501	17	14	9	38,92	9	30	1997,84	9	240	3
411.1509	20,5	17	11	22,55	11	40	1005,10	5	240	4
411.1511	20,5	17	11	45,21	11	40	2010,42	9	240	4

Tab. 17

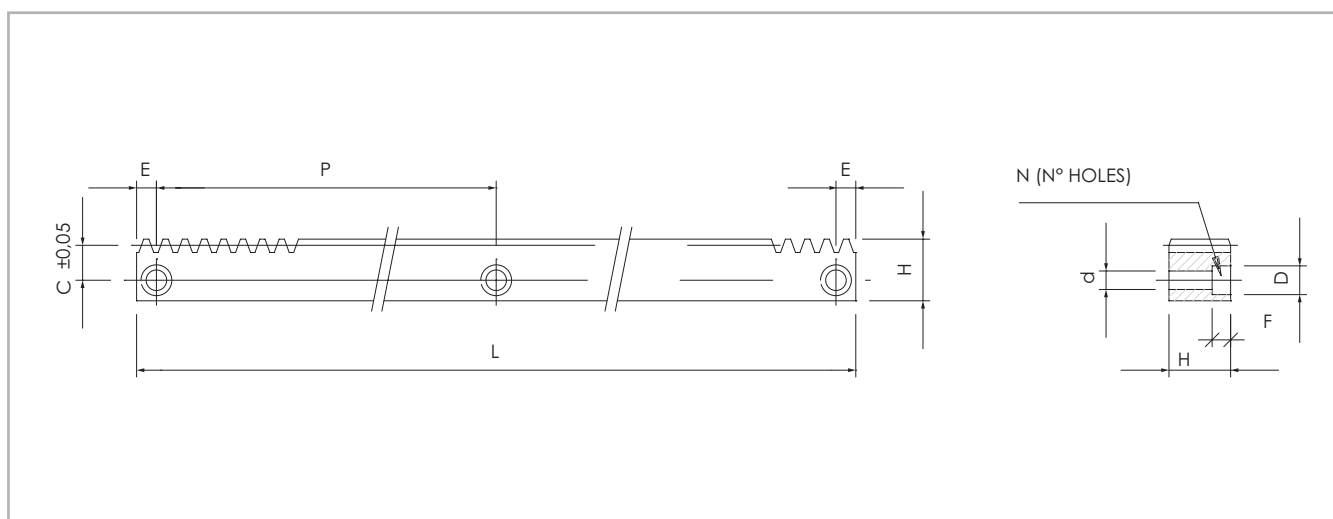

Fig. 126

Indexing rack mounting components

Rack	Mounting plates	Dovetails	Inserts
m2	SR-18, SR-24, SR-32, SR-60	SR-17, SR-24	SR-55
m3	SR-32, SR-65	SR-31	SR-55
m4	SR-32, SR-65	SR-31	SR-55

Tab. 18

> Standard scrapers

Scraper for floating and full-block assemblies

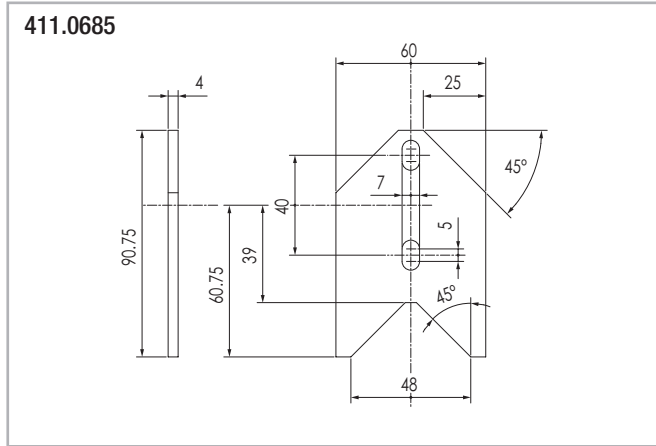

Fig. 127

Scraper for compact

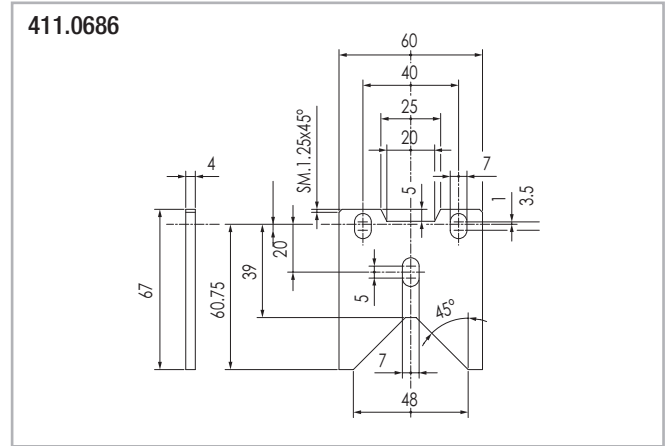

Fig. 128

Sliding brush for speedy rail and steel rail.
Brushes are kept against tracks by springs.

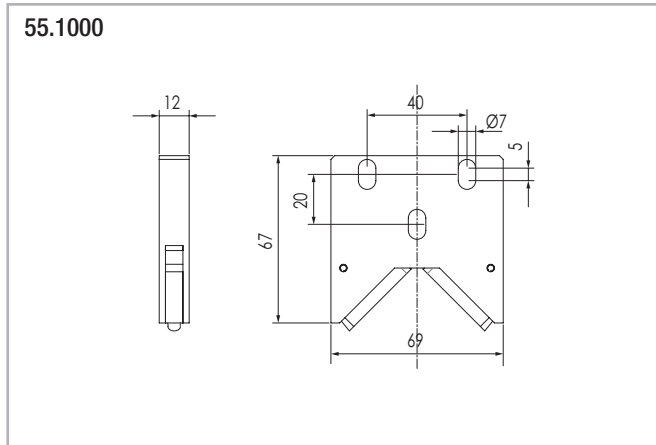

Fig. 129

Scraper for light floating rollers assemblies

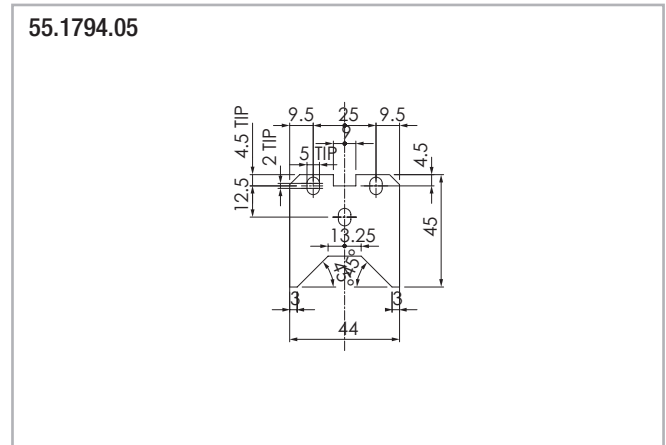

Fig. 130

Scraper for blindo beam roller assemblies

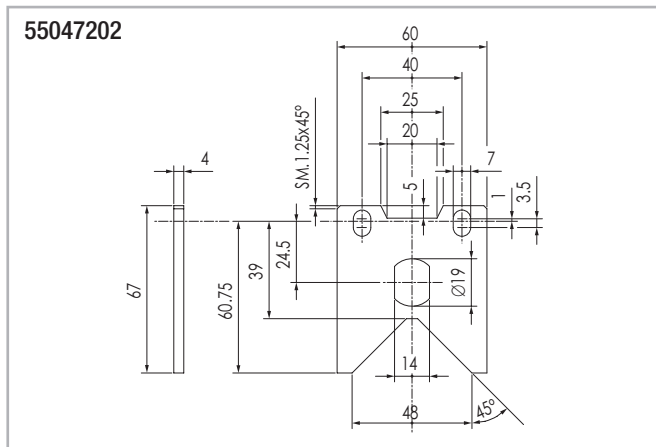

Fig. 131

Note:

All roller assemblies are equipped with the relate scrapers.

Speedy Rail 180



> Wide body multi groove speedy rail guide and specifications

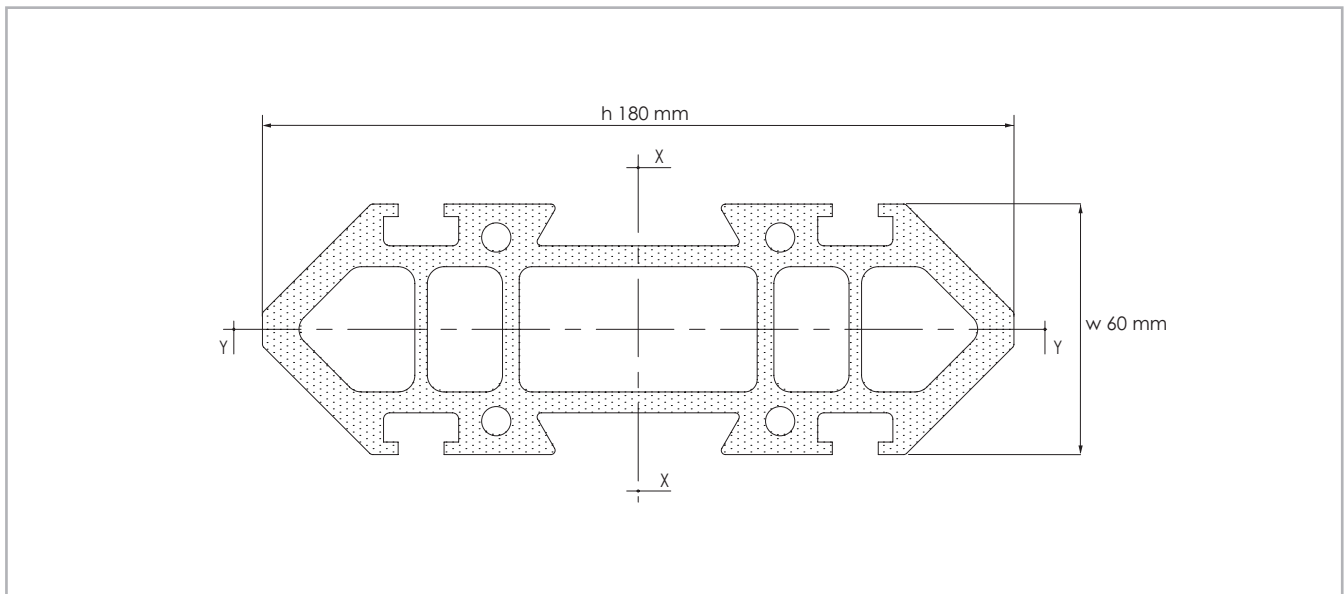

Fig. 132

Surface quadratic moment: X-X axis = 10.291.100 mm⁴ / Y-Y axis = 1.278.700 mm⁴.

Max. manufacturing tolerances = ± 0.30 mm across opposite rolling surfaces.

Max. angular distorsion = $\pm 20'$ /m.

Linear mass = 10.2 Kg/m.

Max. linear distorsion = ± 0.7 mm/m.

Standard lengths: 3000-3500-4000-4500-5000-5500-6000-6500-7000-7500 mm.

External surface: deep hard anodizing

> Roller assemblies and components

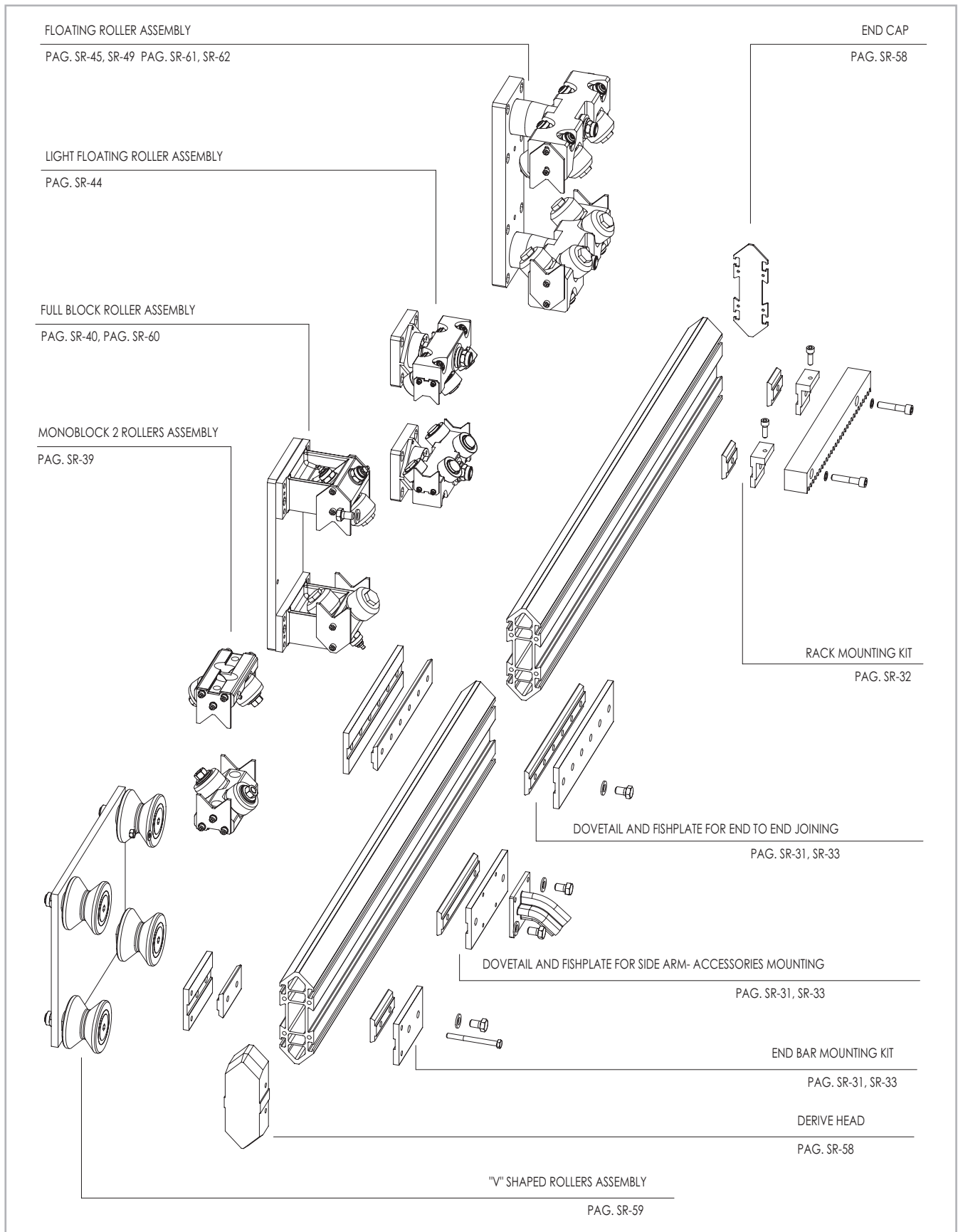

Fig. 133

> Wide body multi groove speedy rail guide and specifications

Speedy Rail 180 with plain ends: SR180-T

Speedy Rail 180 with drilled ends: SR180-F

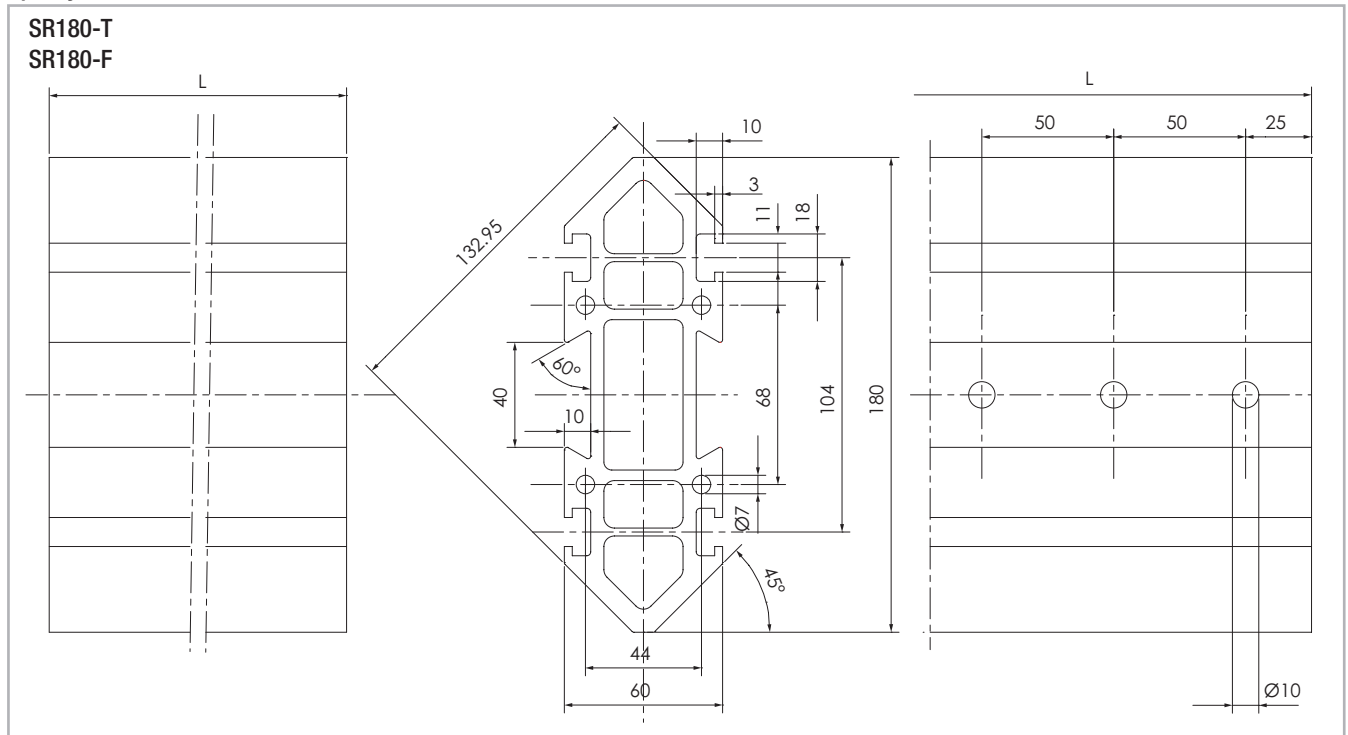

Fig. 134

Note:

Drillings on the bar end are required as a safety measure whith end-to-end joining in moving rails.

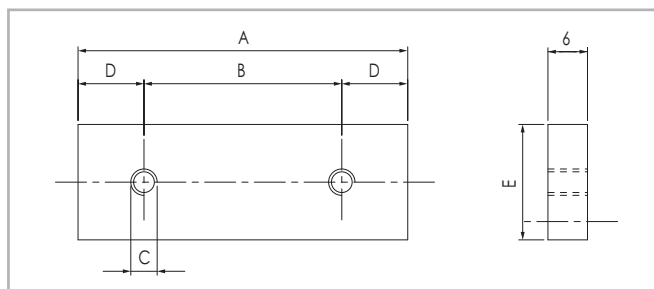

Fig. 135

Insert

A	B	C	D	E	Material	N° Holes	Cod.
496	60	M4	8	16	Burnished steel	9	411.2534
496	60	M5	8	16		9	411.2533
496	80	M6	8	16		9	411.3633

Tab. 19

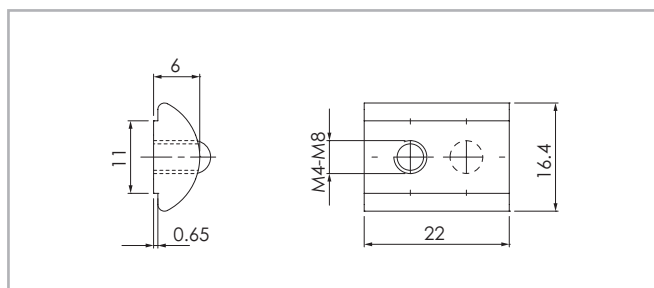

Fig. 136

Insert

A	B	C	D	E	Material	N° Holes	Cod.
-	-	M4	-	-	Zinc plated steel	1	411.1349
-	-	M5	-	-		1	411.1351
-	-	M6	-	-		1	411.1352
-	-	M8	-	-		1	411.1353

Tab. 20

Wide body multi groove speedy rail guide (SR180) uses the same do-
vetails, plates, fishplates and joining components of speedy rail standard

(SR120 section) see page SR-31, SR-32, SR-33

> Components for wide body multi groove Speedy Rail guide

Drive head

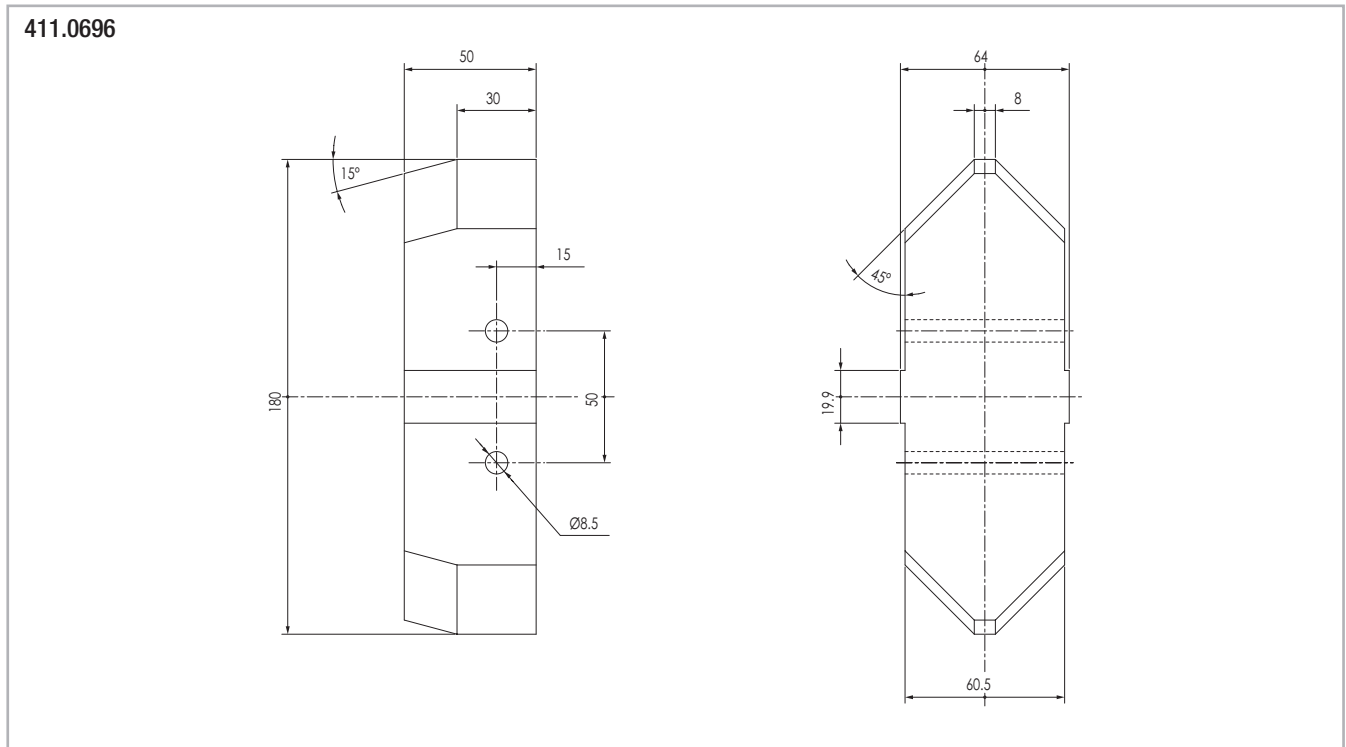

Fig. 137

Bolt for drive head

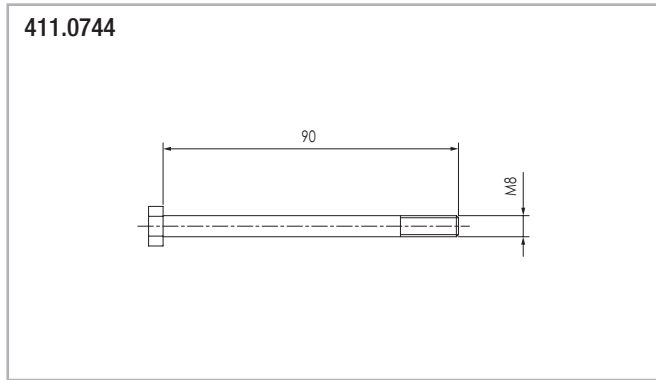

Fig. 138

Aluminium alloy end cap

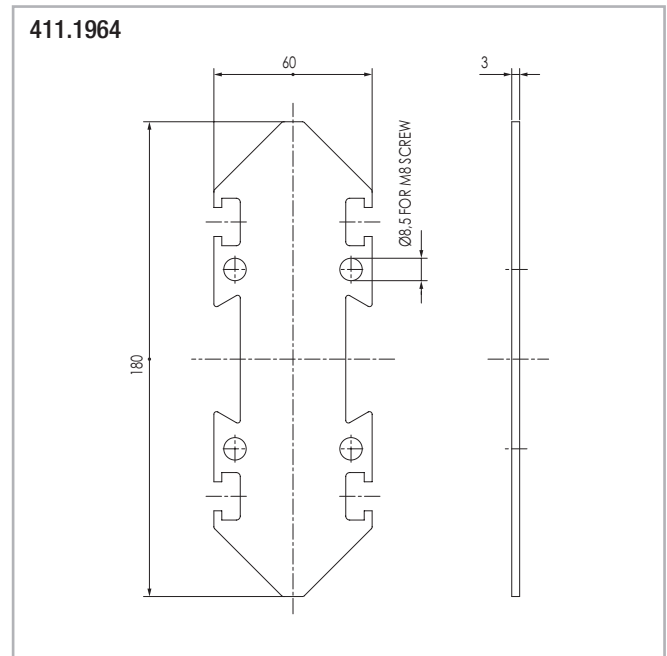

Fig. 139

> Roller assembly with "V" shaped rollers

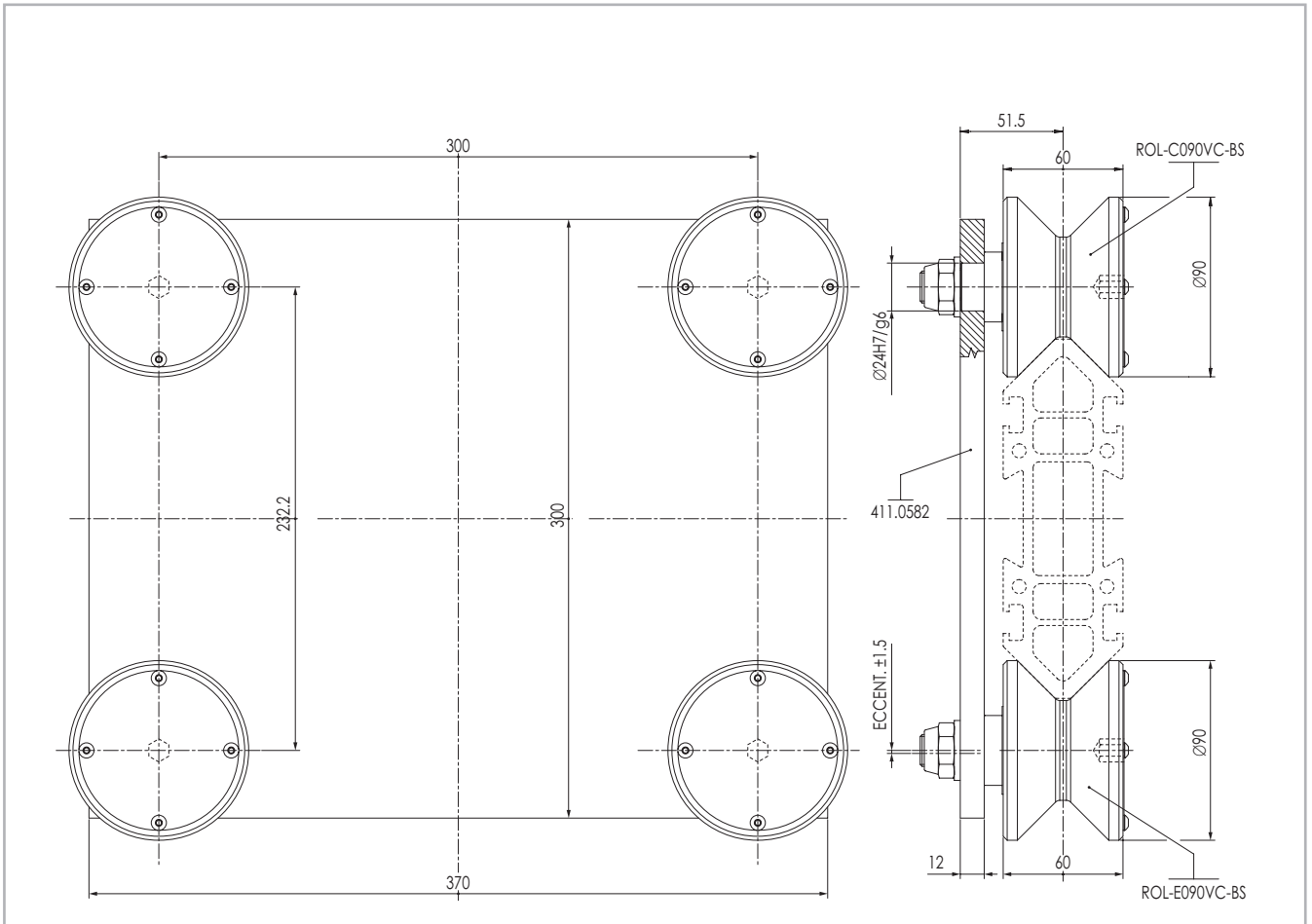

Fig. 140

55.1180

Heavy duty roller assembly with 4 rollers, two ROL-C090VC-BS and two ROL-E090VC-BS.

> Roller assembly with 4 rollers

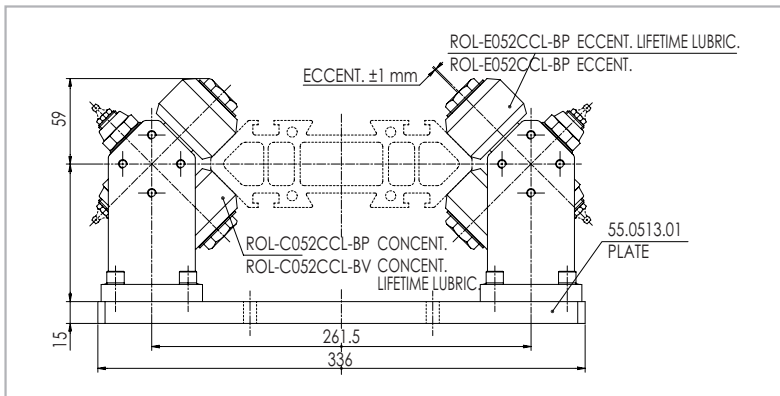

Fig. 141

55.0713

Roller assembly with backing plate 336x150x15 rollers with lifetime lubrication

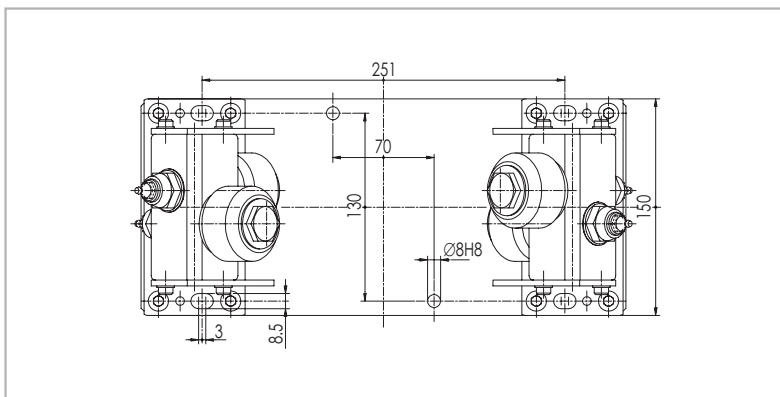

Fig. 142

55.0513

Roller assembly with backing plate 336x150x15 rollers with periodical lubrication

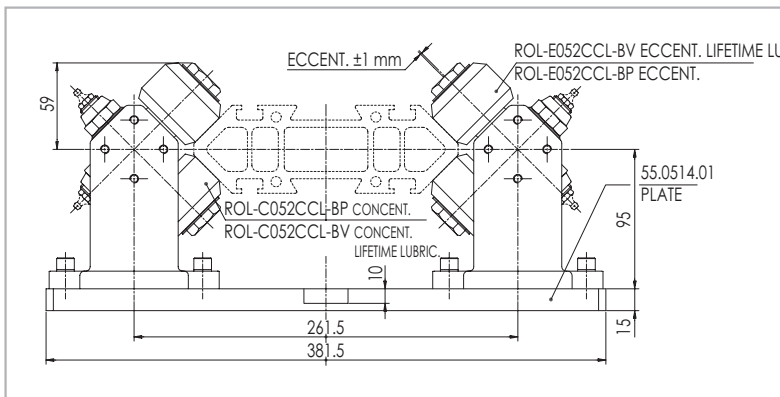

Fig. 143

55.0740

Roller assembly with backing plate 381.5x80x15 rollers with lifetime lubrication

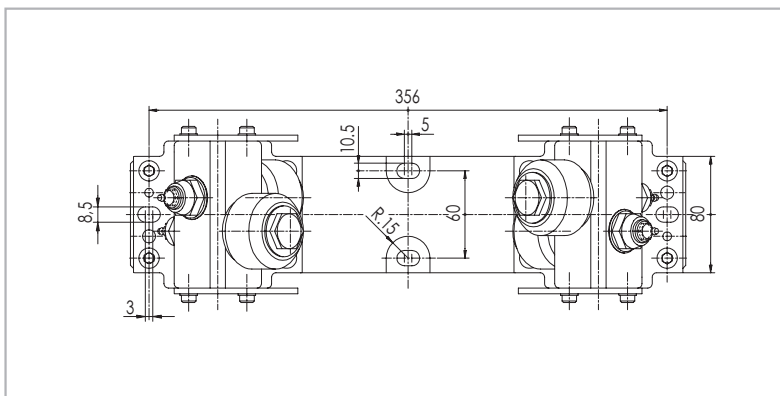
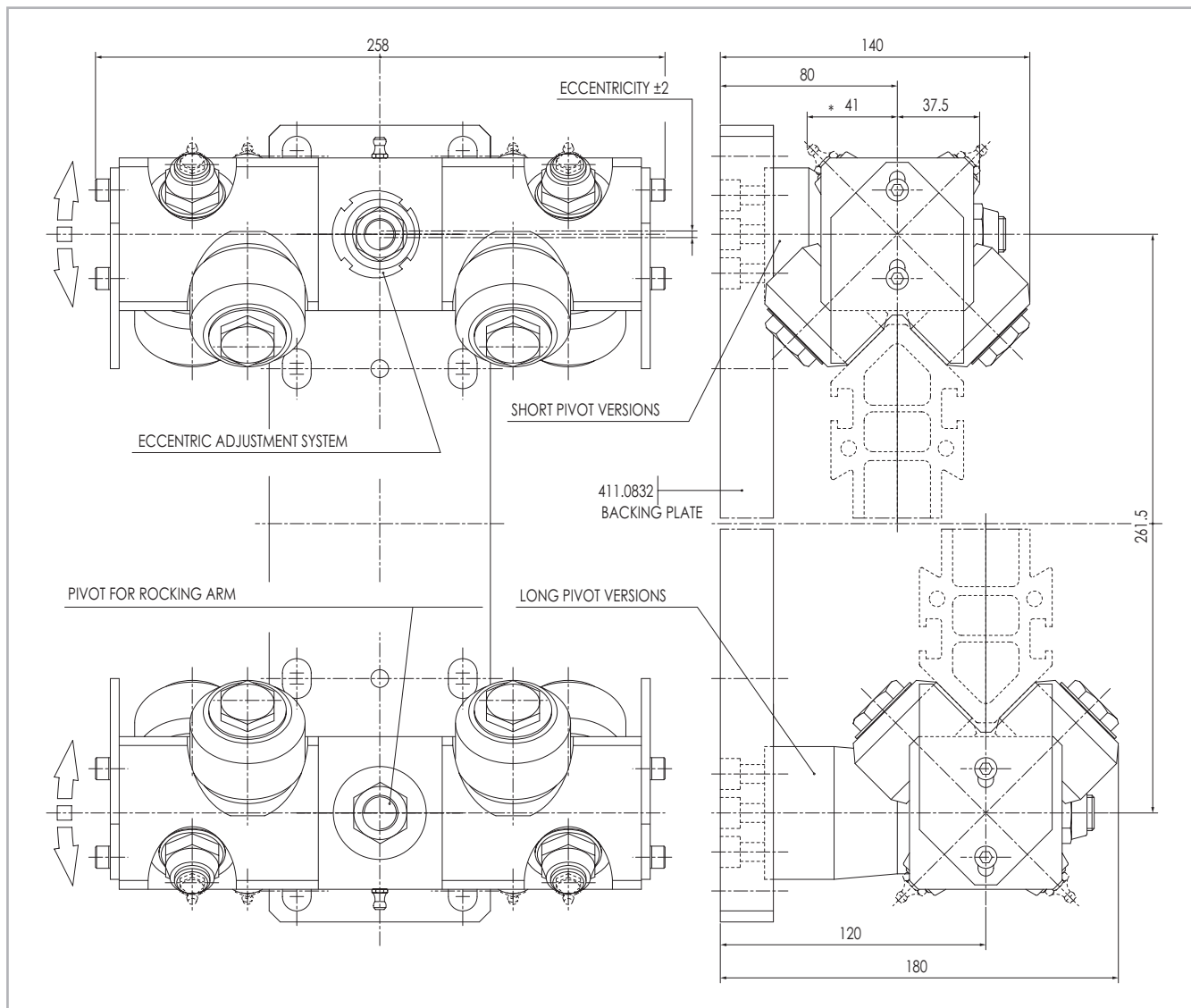

Fig. 144

55.0514

Roller assembly with backing plate 381.5x80x15 rollers with periodical lubrication

> 8 Rollers floating assembly - complete pairing



* Lubricator nipple mounted for periodic lubrication versions only

Fig. 145

Notes:

The complete pairing kit comes with one eccentric and one concentric roller assembly mounted on a backing plate. The concentric roller assembly should take the heavier load. For trolley on 2 parallel guides use on one guide axially free roller assemblies ($\pm 4\text{mm}$).

Pairing kits are available with two roller assemblies having the same number of rollers. For different combinations (i.e. upper assembly with 6 rollers and lower assembly with 4 rollers, two eccentric rollers assemblies) please order the assemblies separately, without baseplate and add the backing plate shown in this page. However we suggest to verify always with our technical department prior to ordering.

Pivot type	Lubrication type	Axially constrained	Axially free
Short pivot	Periodical	55.1380	55.3380
	Lifetime	55.1381	55.3381
Long pivot	Periodical	55.1382	55.3382
	Lifetime	55.1383	55.3383

Tab. 21

> Backing plate for floating roller assemblies

Backing plate - Material: hard anodized aluminium alloy

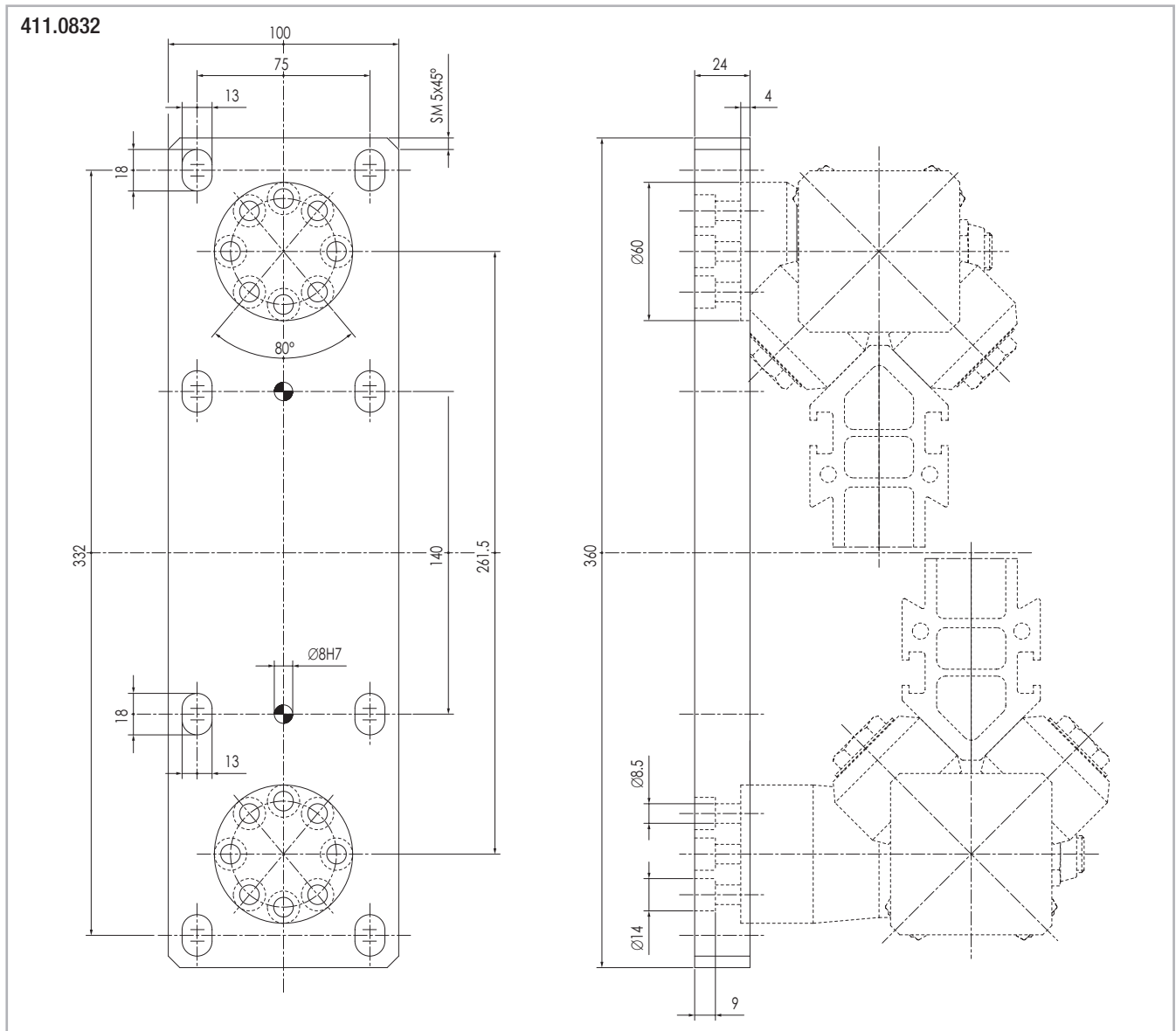

Fig. 146

Fishplate for mod.2 Rack mounting on SR180, SR250 T grooves

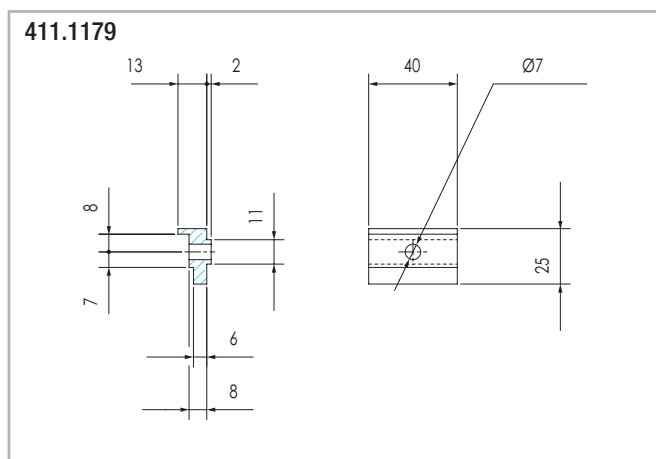

Fig. 147

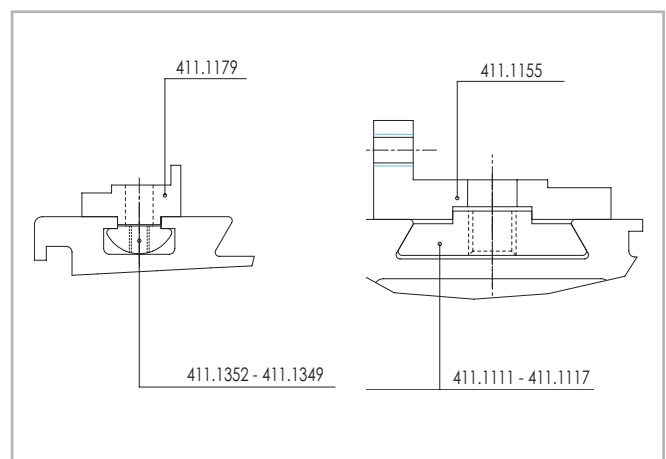

Fig. 148

For rack mounting plate mod.2 Use insert 411.1352

Speedy Rail 250



> Super wide body multi groove Speedy Rail guide and specifications

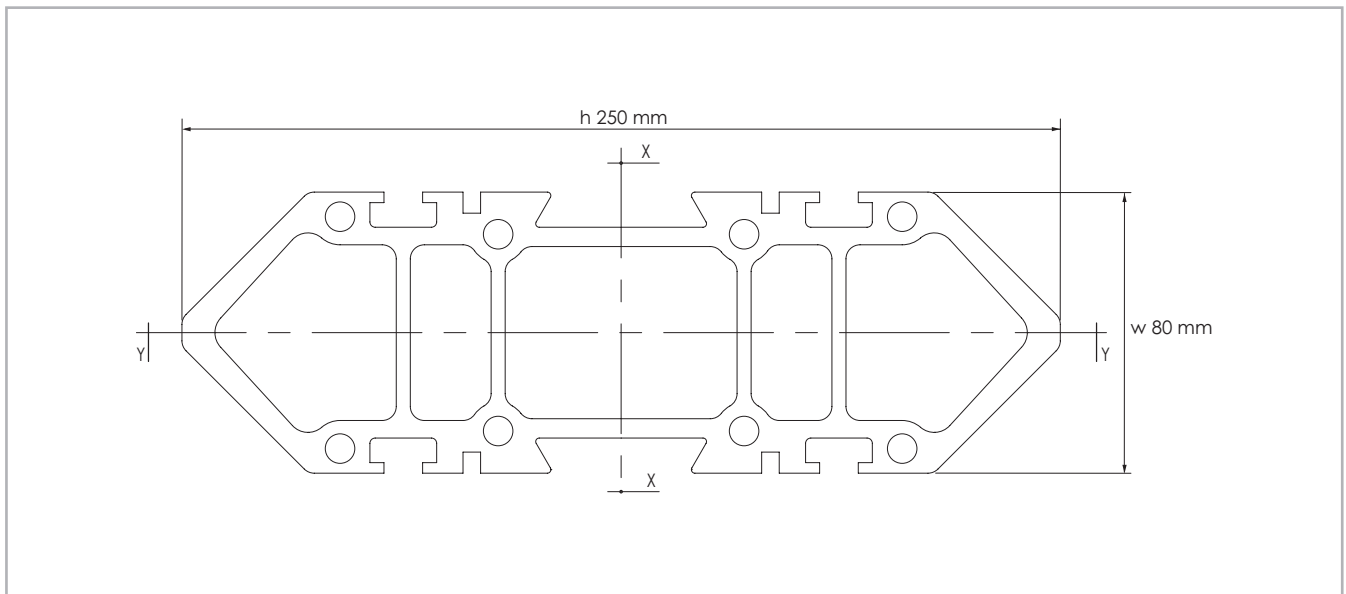

Fig. 149

Surface quadratic moment X-X axis = 27.345.460 mm⁴ / Y-Y axis = 4.120.150 mm⁴.

Max. manufacturing tolerances = ± 0.65 mm across opposite rolling surfaces.

Max. angular distortion = $\pm 30'$ /m.

Linear mass = 15.20 Kg/m.

Max. linear distortion = ± 0.5 mm/m.

Standard lengths: 3000-3500-4000-4500-5000-5500-6000-6500-7000-7500 mm.

External surface: deep hard anodizing

> Roller assemblies and components

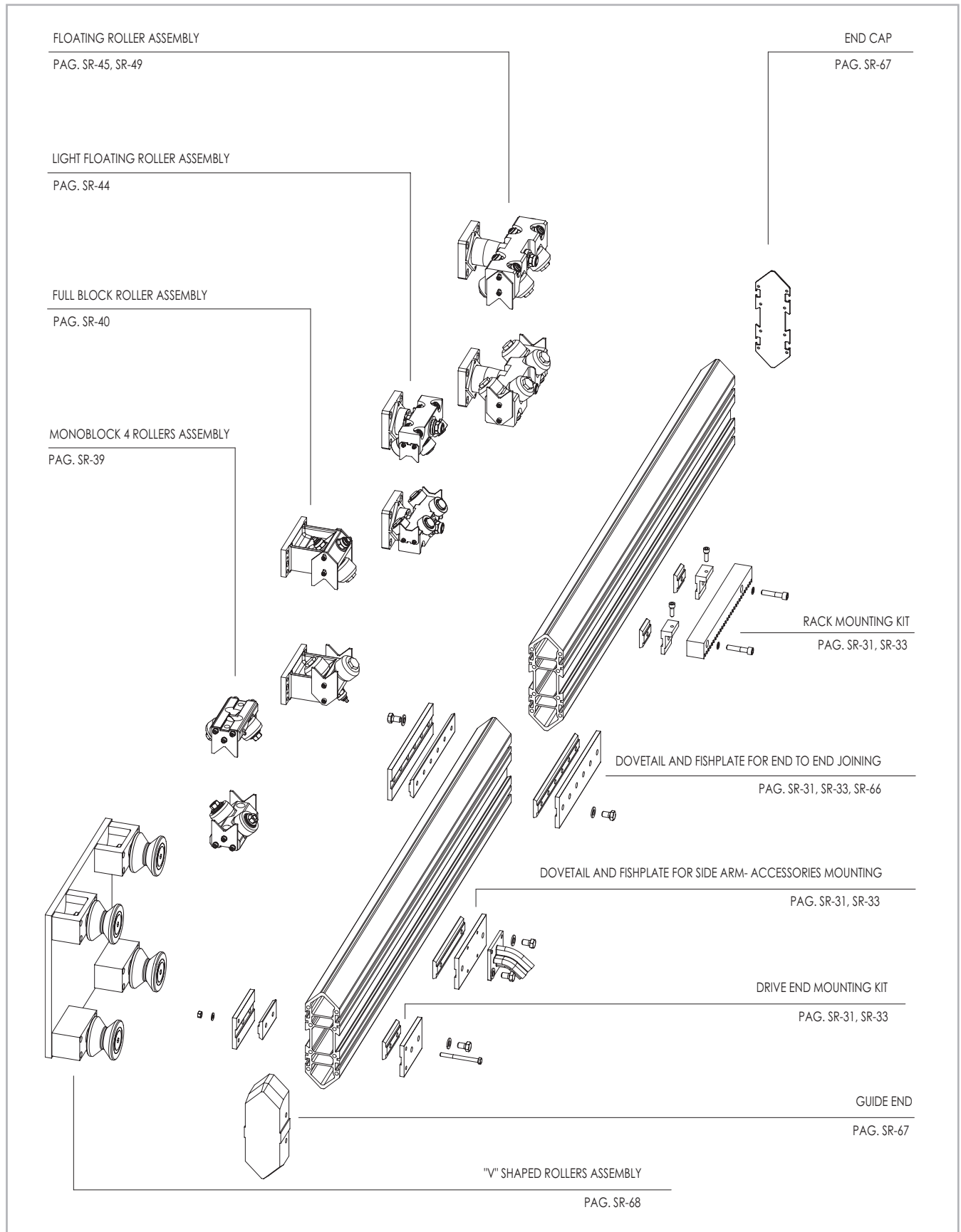

Fig. 150

> Superwide body multi groove Speedy Rail guide and specifications

Speedy Rail 250 with plain ends: SR250-T
 Speedy Rail 250 with drilled ends: SR250-F

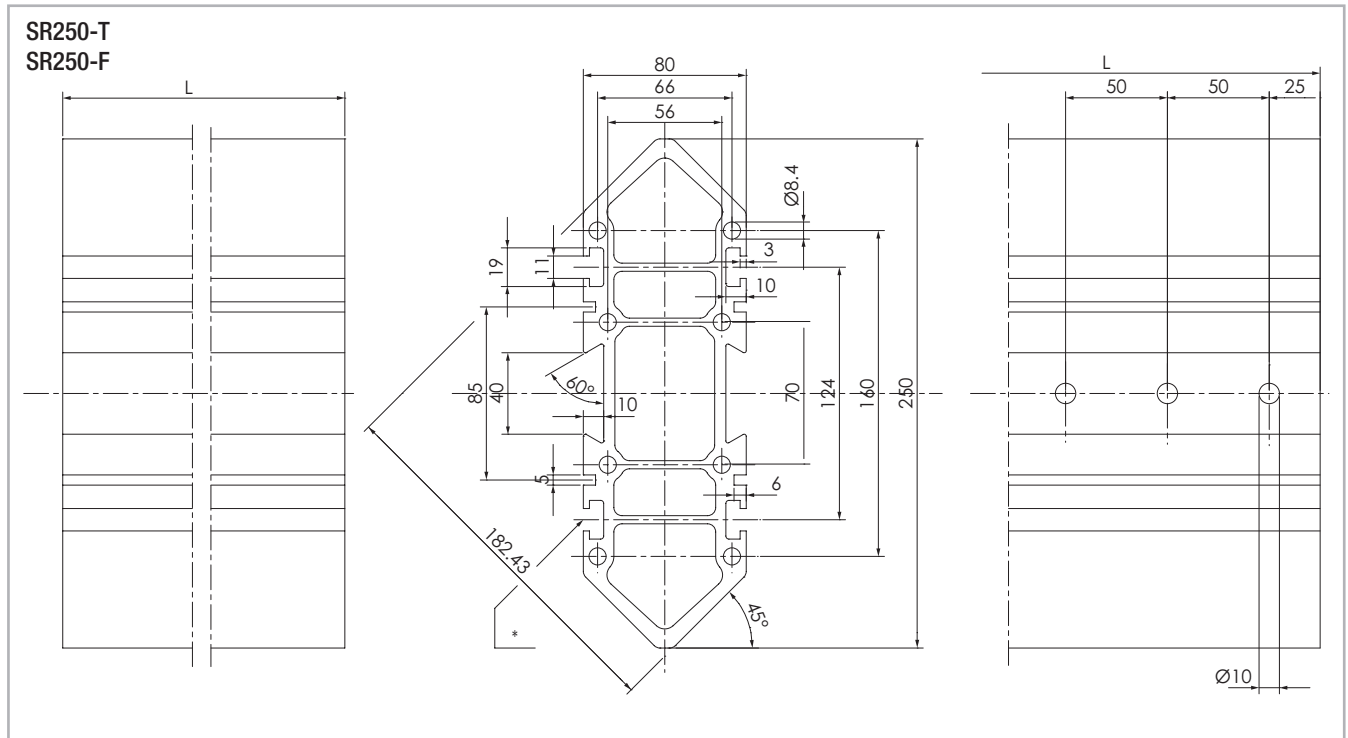

Fig. 151

Note:

Drillings on the bar end are required as a safety measure with end-to-end joining in moving rails.

Super wide body multi groove speedy rail guide (SR250) uses the same dovetails, plates, fishplates and joining components of speedy rail standard (sr 120m section) see pages SR-31, SR-32, SR-33. Special plates, 411.0960, are also available for end-to-end joining in heavy duty applications.

* Particularly for side grooves the same inserts for SR180 (pag.SR-57) are used.

Steel fishplates for end to end joining

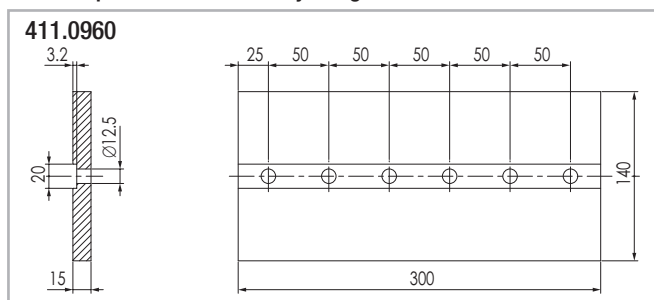

Fig. 152

S
R

> Components for super wide body Speedy Rail guide

Aluminium alloy end cap

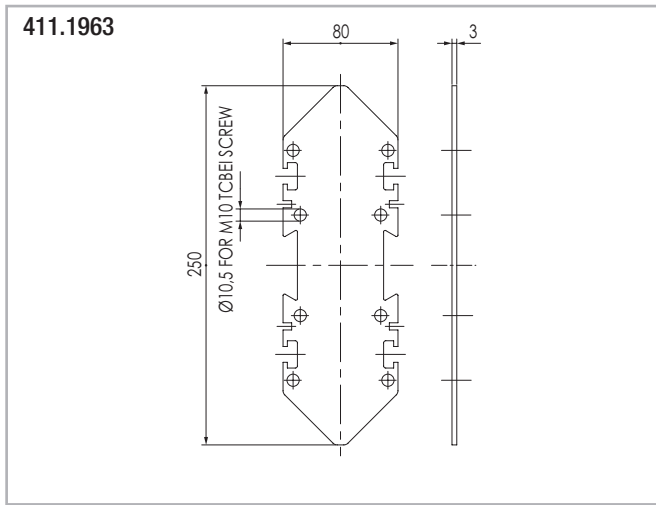

Fig. 153

Elastomer drive head

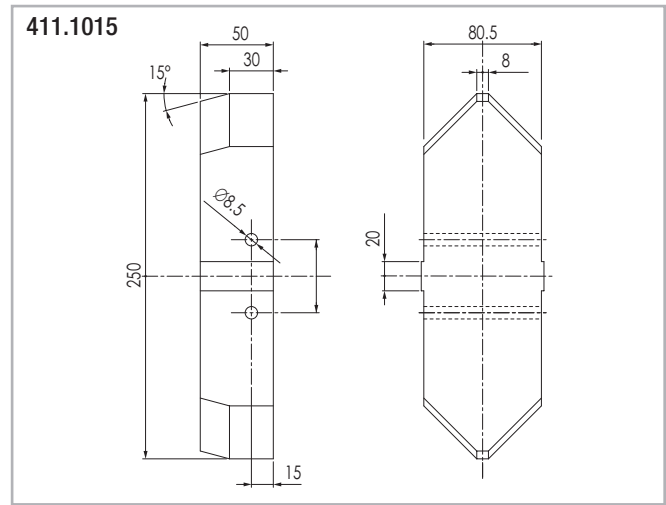

Fig. 154

> Roller assembly with "V" shaped rollers

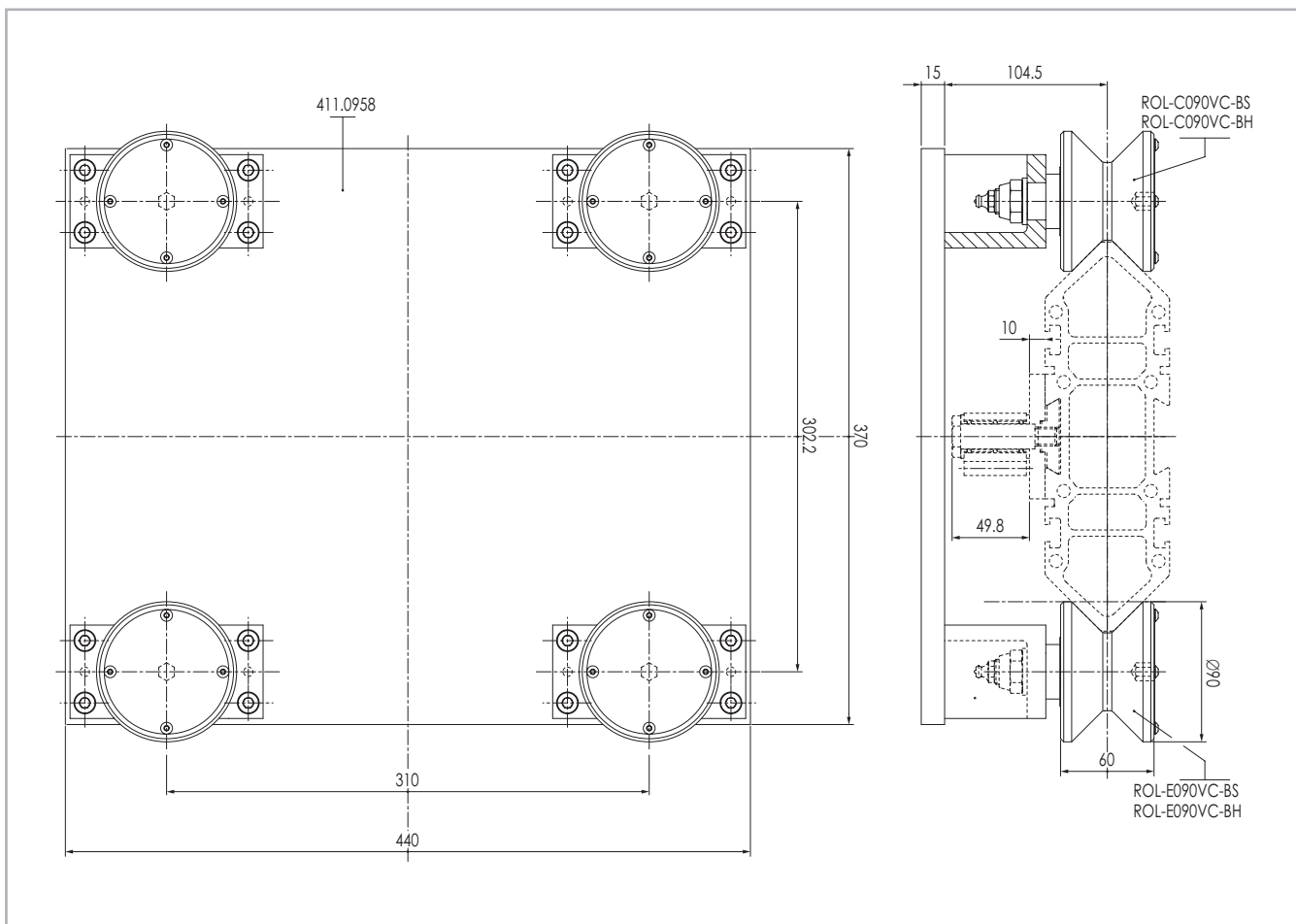
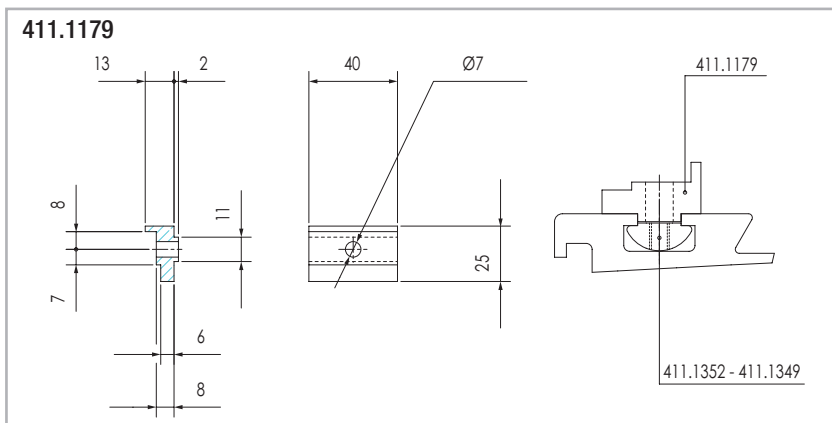

Fig. 155

55.0808

Roller assembly with 4 rollers, two ROL-C090VC-BS and two ROL-E090VC-BS

Fishplate for mod.2 Rack mounting on, SR180, SR250 T grooves



Mod.2 straight toothed

Fig. 156

For rack mounting plate mod. 2 use insert 411.1352

Fishplate for mod. 3 and 4 rack mounting on dovetail grooves

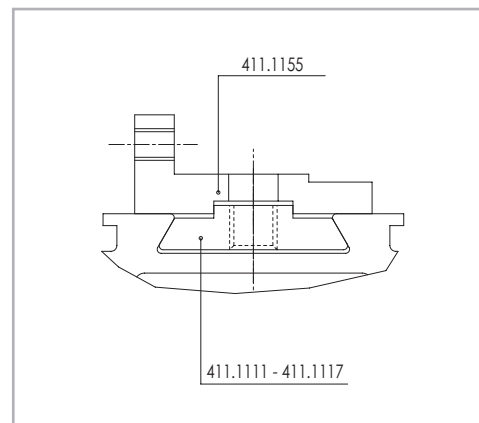

Mod.3 e 4

Fig. 157

Technical detail



> Mechanical and technological components specifications

Guides	Accessories	Material	Tensile strength
Speedy Rail SR 35 Speedy Rail SR C 48 Speedy Rail Mini SR 60 Speedy Rail Middle SR 90 Speedy Rail Standard SR 120 Speedy Rail Wide Body multiple grooves SR 180 Speedy Rail Super Wide Body Multiple Grooves SR 250	Dovetails Fishplates	Aluminum Alloy	Tensile strength: $R = 245 \text{ N/mm}^2$ Yield stress: $S = 195 \text{ N/mm}^2$ Elongation: $10\% \div 13\%$ Modulus of elasticity: $E = 70000 \text{ N/mm}^2$ $G = 26000 \text{ N/mm}^2$ Mass density: $2,7 \text{ kg/dm}^3$ Coefficient of expansion: $K = 23 \times 10^{-6} \text{ mm/mm}^\circ\text{C}$

Tab. 22

Components	Material	Tensile strength
Base plates Rocking arms Compact rollers assembly body	Aluminum Alloy	Tensile strength: $R = 275 \text{ N/mm}^2$ Yield stress: $S = 200 \text{ N/mm}^2$ Elongation: $10\% \div 13\%$ Modulus of elasticity: $E = 70000 \text{ N/mm}^2$ $G = 26000 \text{ N/mm}^2$ Mass density: $2,7 \text{ kg/dm}^3$
Monoblock roller assembly case Full-block roller assembly case		Tensile strength: $R = 225 \text{ N/mm}^2$ Yield stress: $S = 142 \text{ N/mm}^2$ Elongation: $3\% \div 5\%$ Modulus of elasticity: $E = 70000 \text{ N/mm}^2$ $G = 26000 \text{ N/mm}^2$ Mass density: $2,7 \text{ kg/dm}^3$

Tab. 23

> Treatments on all light alloy components

Heat treatment	Age hardening
Surface treatment	<p>Surface hardening: Low temperature deep anodizing to give a surface hardness of 600 ÷ 700 HV</p> <p>Surface layer depth: 50÷60 micron (0.050÷0.060 mm) for rails, 25÷35 micron (0.025÷0.035 mm) for supports bodies and plates.</p> <p>Chemical composition of surface layer: Al₂ O₃</p> <p>Fusion temperature of surface layer: 2100° C</p> <p>Surface layer electric resistance at 20°C: 4x10¹⁵ Ohm/cm/cm²</p> <p>Dielectric constant: approx. 7.5</p> <p>Puncture voltage of surface layer: 1500 V</p>

Tab. 24

> Rollers

Speedy Rail system

Rollers are manufactured with a steel shaft, high quality ball-needle bearings, rubber seals labyrinth.

The external surface of the roller is machined with a slightly convex profile, finished with a sintered plastic compound having the following properties:

Tensile strength:	85 N/mm ²
Rockwell hardness:	120 R
Melting point:	+ 220 °C
Max. continuous working temperature:	+80°C
Min. continuous working temperature:	- 30°C
Dynamic friction coefficient:	0,25

Chemical resistance: excellent to mineral and organic oils; good to basic solutions; fairly good to acid solutions.

We always recommend a preliminary test for the rollers in the actual working environment.

> Roller assemblies

Roller assemblies with four (4) rollers have the two inner rollers mounted on a plain, concentric sleeve while the outer ones have an eccentric sleeve. This setup allows the proper adjustments to compensate dimensional tolerances on the rail. Two roller assemblies have one roller with an eccentric sleeve and the other with a concentric setup.

Floating roller assemblies: all the rollers on this type of support have a concentric sleeve.

The adjustments are made possible by the pivot settings (hub), which comes either with an eccentric or concentric setup.

Custom configuration for roller assemblies are available upon request.

> Rollers adjustments

Adjusting the rollers on a single section rail requires the rollers in a position that allows them to touch the running surface with no play - slightly pre-loaded- A different and more accurate setting is required when the runway is assembled with multiple sections.

The rollers setting must leave 0.15 ÷ 0.20 mm backslack (play) from the rail –Use a feeler gauge for best results- The setting requirement is determined by the dimensional tolerances on the rail sections.

> Torque settings

Bolt purpose torque:

M6	(fixing scrapers)	10 Nm
M8	(fixing assemblies)	25 Nm
M10	(fixing assemblies)	45 Nm
M12	(dovetails & fishplates)	55 Nm
M16	(fixing rollers)	75 Nm

Drillings of the end bars:

this are made in order to create a security connection for two or more moving rails that have an end to end joining, through the shaft of the special screws that are used for fixing the fishplate and the dovetails. This additional connection is not a guarantee for the precision but has got the aim to avoid injuries in the case that the moving rails unhook.

> Scrapers

Are manufactured from a sintered compound, self lubricating, having a low friction coefficient. All the roller assemblies come with the scrapers. The purpose of this item is to keep foreign bodies out of the rollers. Scrapers shall never be set to slide on the rail.

They are equipped with mounting and adjustment holes so that a 0.2 mm minimum clearance can be applied.

For application environments with an excessive pollution or dust use the mobile brush assembly.

> Drive head

For Speedy Rail profiles. Machined from a hard polymer rubber molding - Shore A hardness 90÷95 - Normally mounted on the bar ends when the system has a rail that moves in and out the roller assemblies. This rubber end piece allows the rail to be easily guided into the roller assemblies.

> Lubrication

There is no need to lubricate our Speedy Rail profiles. However, lubricant is recommended on Steel rail profiles when used with steel rollers. Best results are obtained using our standard oiler. It provides continuous lubrication and keeps the rail clean.

Rollers: standard rollers with regular maintenance/greasing schedule have its own grease nipple. Please use grade 3 grease for working temperature of 10°C÷60°C.

Grade 2 grease is required when the working temperature drop below 10°C. Lubricate every 5-6 months.

For the “lifetime” lubrication version, the rollers are supplied with a high tech grease.

The grease nipples are removed from the assemblies since this configuration does not require any periodic lubrication.

> Life testing

Speedy rail and system with plastic shell rollers

The max applicable load, stated in the description of each roller of the Speedy Rail systems, is determined depending on the characteristics of the plastic compound shell. The cylindrical rollers of Speedy Rail system can be used with translation speed up to 15 metres/second and with accelerations and decelerations up to 10 metres/sec². For Speedy Rail and Speedy Rail C 48 systems with “V” shaped and for Speedy Rail 35 plastic compound rollers, the max translation speed is of 8 metres/second while the max accelerations and decelerations are of 8 metres/sec². For higher dynamics please contact our technical department. For all roller types the working temperature limits are -30°C and +80°C.

The rollers with plastic compound shell do not damage themselves and do not damage the rails where the invert direction, even in presence of high accelerations and decelerations. Speedy Rail C 48 and Speedy Rail 35 systems has good performance and excellent life even in presence of dust. With stresses on the rollers within the max values stated on the catalogue, the Speedy Rail C 48 and Speedy Rail 35 systems enable a life time of more than 80.000 km. The life can be lower due to excessive presence of dust or pollutants.

> Summary table Speedy Rail guides

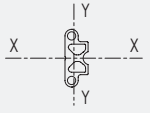
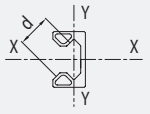
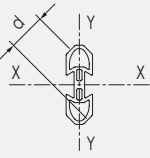
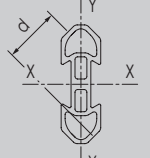
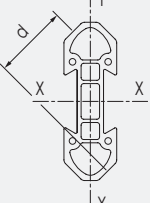
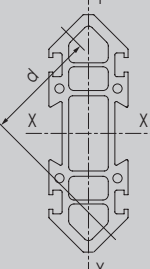
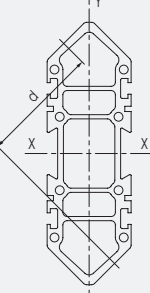
Profile type and code N°	Simple profiles mechanical and specifications	Surface quadratic moment I (X) mm ⁴	Surface quadratic moment I (Y) mm ⁴	Section modulus W (X) mm ³ :	Section modulus W (Y) mm ³ :	Section mm ²	Distance d mm: (Roller contact axis)	Linear mass t kg/mt
SR 35 SIMP - T SIMP - F		17.779	3.665	1016	118	203	/	0.60
SR C 48 CR48 - D CR48 - T CR48 - F		152.026	36.823	6334	2045	526	28.26	1.42
SR Mini (60) SR060 - T SR060 - F		138.600	18.000	4.620	1.800	470	29	1,27
SR Middle (90) SR090 - T SR090 - F		630.000	76.500	14.250	5.170	965	39,6	2,6
SR Standard (120) SR120 - T SR120 - F		2.138.988	259.785	35.650	12.989	1.645	56,1	4,4
SR Wide Body (180) SR180 - T SR180 - F		10.291.100	1.278.700	114.345	42.620	3.730	95,7	10,2
SR Super Wide body (Speedy Rail 250) SR250 - T SR250 - F		27.345.460	4.120.150	218.760	103.000	5.609	113.95	15.2

Tab. 28

> Loads on a 4 'V' rollers trolley

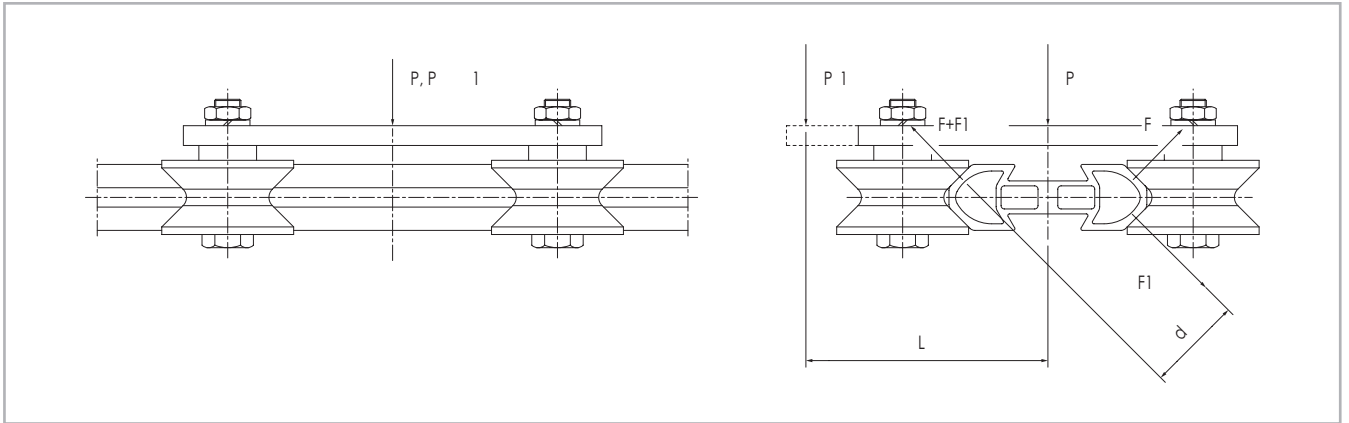

Fig. 158

Rollers load with force 'P' applied on the rail axle

$F = P \cdot \left(\frac{1}{2 \cdot \sqrt{2}} \right) \text{ (N)}$	$F_r = F_a = F \cdot \left(\frac{1}{\sqrt{2}} \right) \text{ (N)}$	<p> P, P_1 = Applied forces (N) F_r = Radial load (N) F_a = Axial load (N) </p>
---	---	--

Fig. 159

Rollers load with 'P₁' force applied at 'L' distance (mm) from rail centerline

$F = P_1 \cdot \left(\frac{1}{2 \cdot \sqrt{2}} \right) \text{ (N)}$	$F_1 = \frac{P_1 \cdot L}{2 \cdot d} \text{ (N)}$	$F_r = F_a = \frac{F + F_1}{\sqrt{2}} \text{ (N)}$	<p> P, P_1 = Applied forces (N) F_r = Radial load (N) F_a = Axial load (N) </p>
---	---	--	--

Fig. 160

Important: the load on most loaded rollers must be, for each roller type, less or equal to the corresponding rated load on the catalogue.

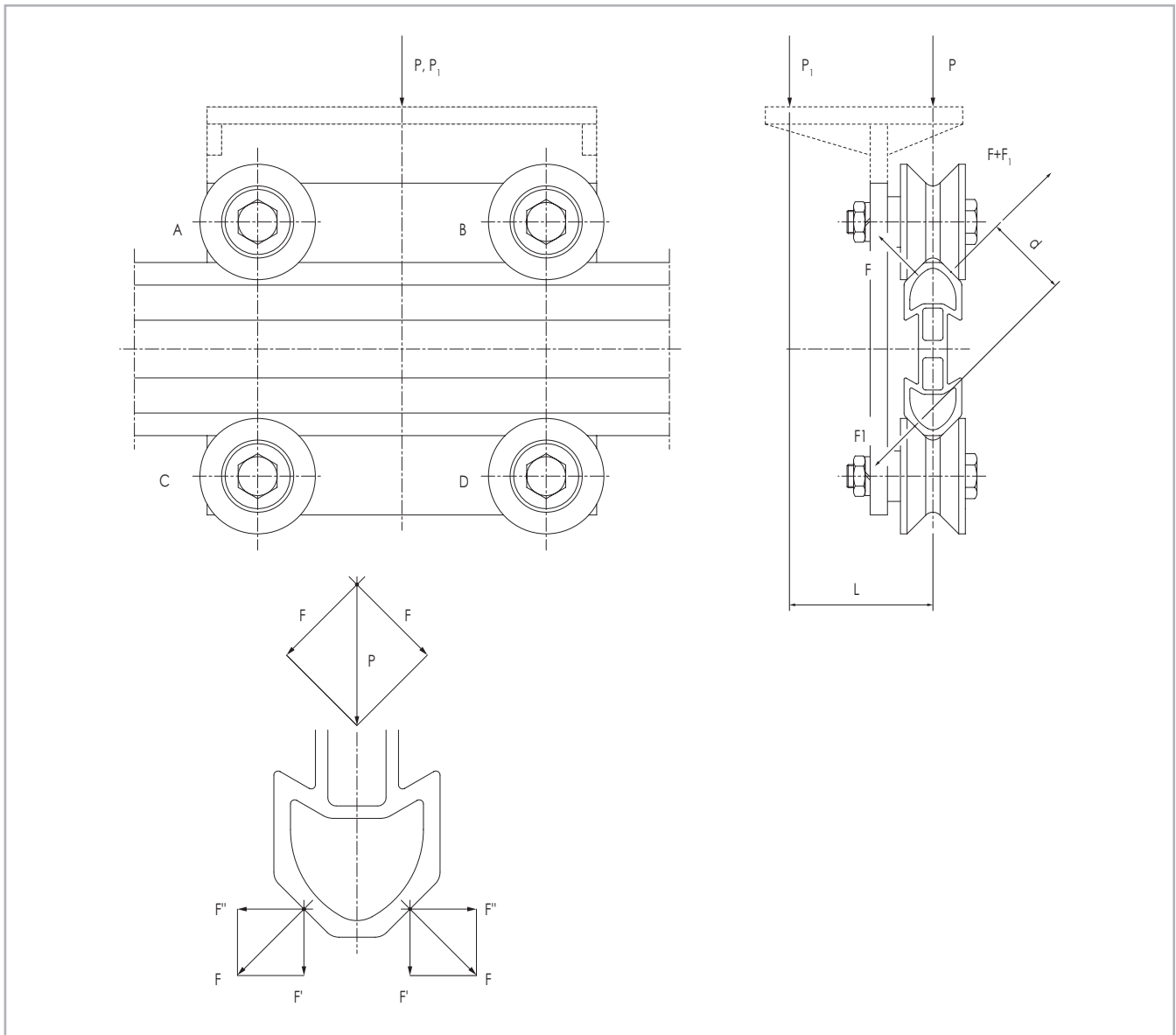

Fig. 161

$$F' = F'' = \frac{F}{\sqrt{2}}$$

- A, B Concentric rollers
- C, D Eccentric rollers
- P, P₁ = Applied forces (N)
- F_r = Radial load (N)
- F_a = Axial load (N)

Fig. 162

Rollers load with force 'P' applied on the rail axle

$F_r = \frac{P}{2} \text{ (N)}$	$F_a = 0 \text{ (N)}$	<p>A, B Concentric rollers C, D Eccentric rollers P, P₁ = Applied forces (N) F_r = Radial load (N) F_a = Axial load (N)</p>
---------------------------------	-----------------------	--

Fig. 163

Rollers load with 'P₁' force applied at 'L' Distance (mm) from rail centerline

$F = P_1 \cdot \frac{1}{2 \cdot \sqrt{2}} \text{ (N)}$	$F_1 = \frac{P_1 \cdot L}{2 \cdot d} \text{ (N)}$	$F_r = \sqrt{2} \cdot F + \frac{F_1}{\sqrt{2}} \text{ (N)}$	$F_a = \frac{F_1}{\sqrt{2}} \text{ (N)}$	<p>A, B Concentric rollers C, D Eccentric rollers P, P₁ = Applied forces (N) F_r = Radial load (N) F_a = Axial load (N)</p>
--	---	---	--	--

Fig. 164

Important: the load on most loaded rollers must be, for each roller type, less or equal to the corresponding rated load on the catalogue.

Trolley on single rail horizontal

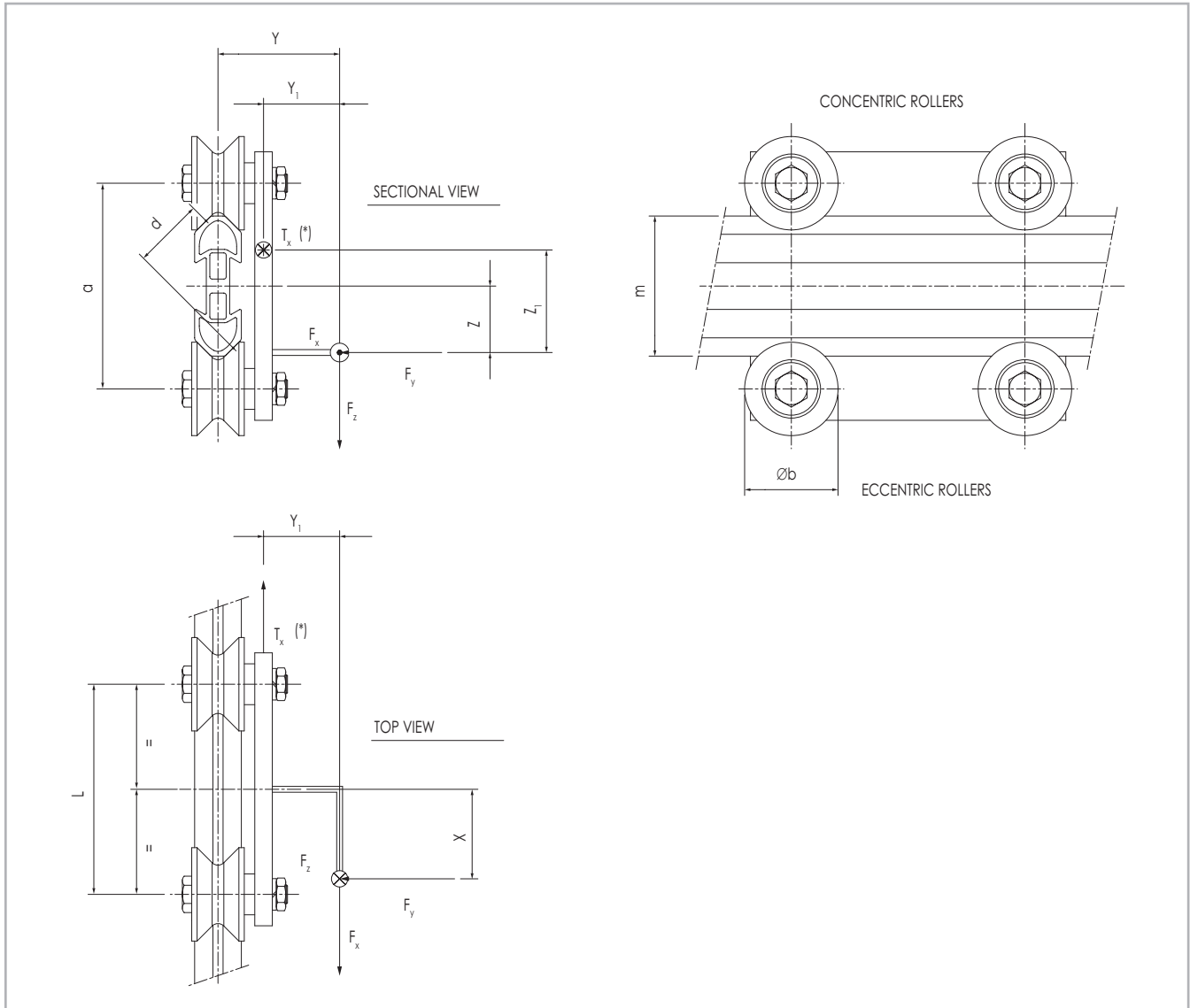

(*) Traction force (chain or belt) $T_x = F_x$

Fig. 165

The rollers with concentric sleeve are mounted where there is the highest load and the ones with eccentric sleeve on the opposite end.

All 'F' values must include the dynamic component obtained by:
 Inertia force = mass (kg) x acceleration (mt/s^2).

Roller-guide load verification

$$F_{Ass} \Rightarrow \frac{F_y}{4} + \frac{F_y \cdot X + F_x \cdot Y_1}{2 \cdot L} + \frac{F_z \cdot Y + F_y \cdot Z}{2 \cdot d \cdot 1.41}$$

$$F_{Rad} \Rightarrow \frac{F_y}{4} + \frac{F_z \cdot X - F_x \cdot Z_1}{L} + \frac{F_z \cdot Y + F_y \cdot Z}{2 \cdot d \cdot 1.41}$$

Fig. 166

Important: the load on most loaded rollers must be, for each roller type, less or equal to the corresponding rated load on the catalogue.

> Loads on twin 4 'V' rollers trolleys

Trolley on double rail horizontal

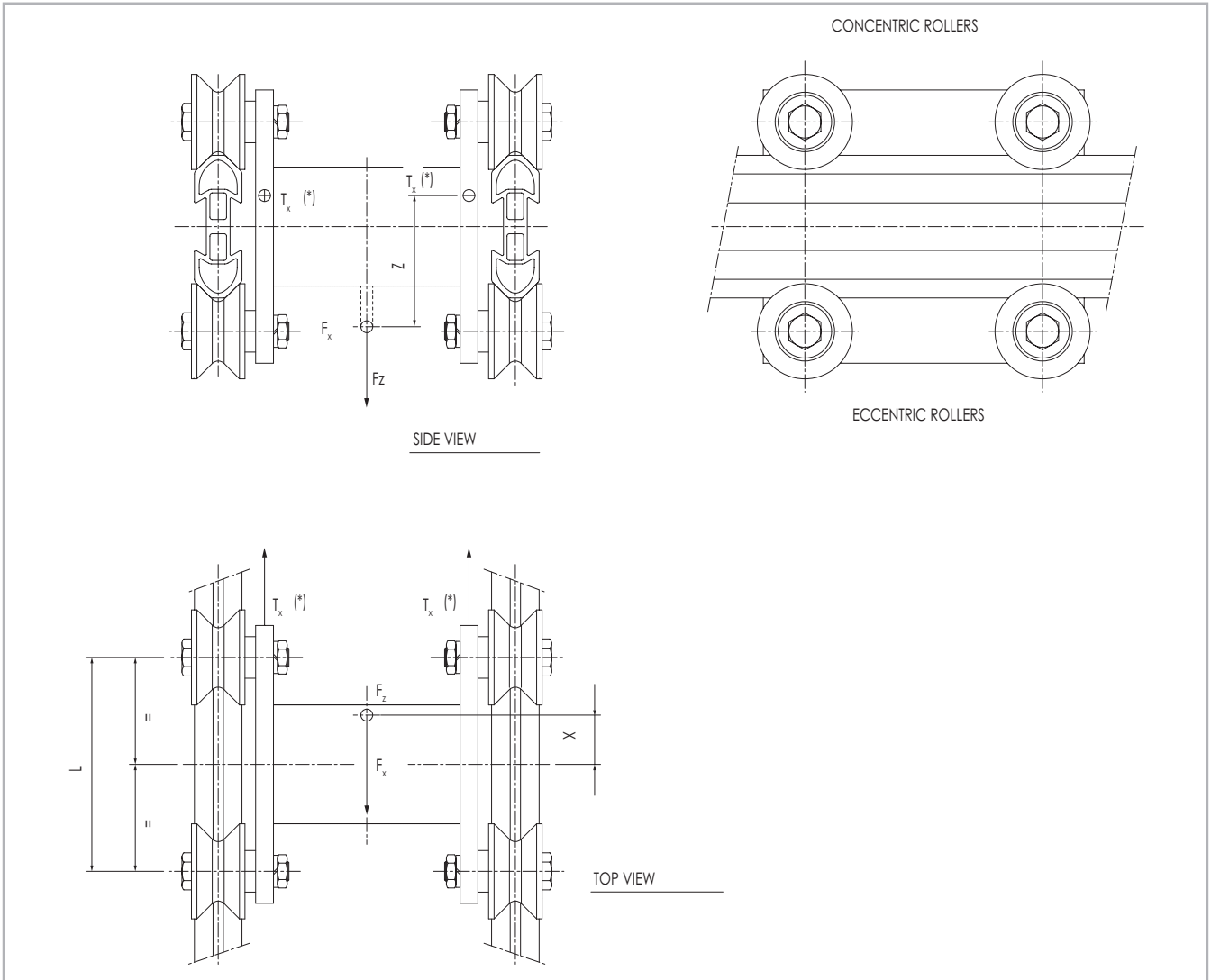

(*) Traction force (chain or belt) $T_x = F_x / 2$

Fig. 167

When assembling lines with parallel rail and long strokes it would be wise to use axially-free roller assemblies on one of the rails in order to withstand minor misalignments due either to assembly or maintenance errors.

All 'F' values must include the dynamic component obtained by:
 Inertia Force = mass (kg) x acceleration (m/s²).

Roller-guide load verification

$$F_{Rad} \Rightarrow \frac{F_z}{4} + \frac{F_x \cdot Z + F_z \cdot X}{2 \cdot L}$$

Fig. 168

Important: the load on most loaded rollers must be, for each roller type, less or equal to the corresponding rated load on the catalogue.

> Loads on a 4 'V' rollers vertical trolley

Trolley on single vertical rail

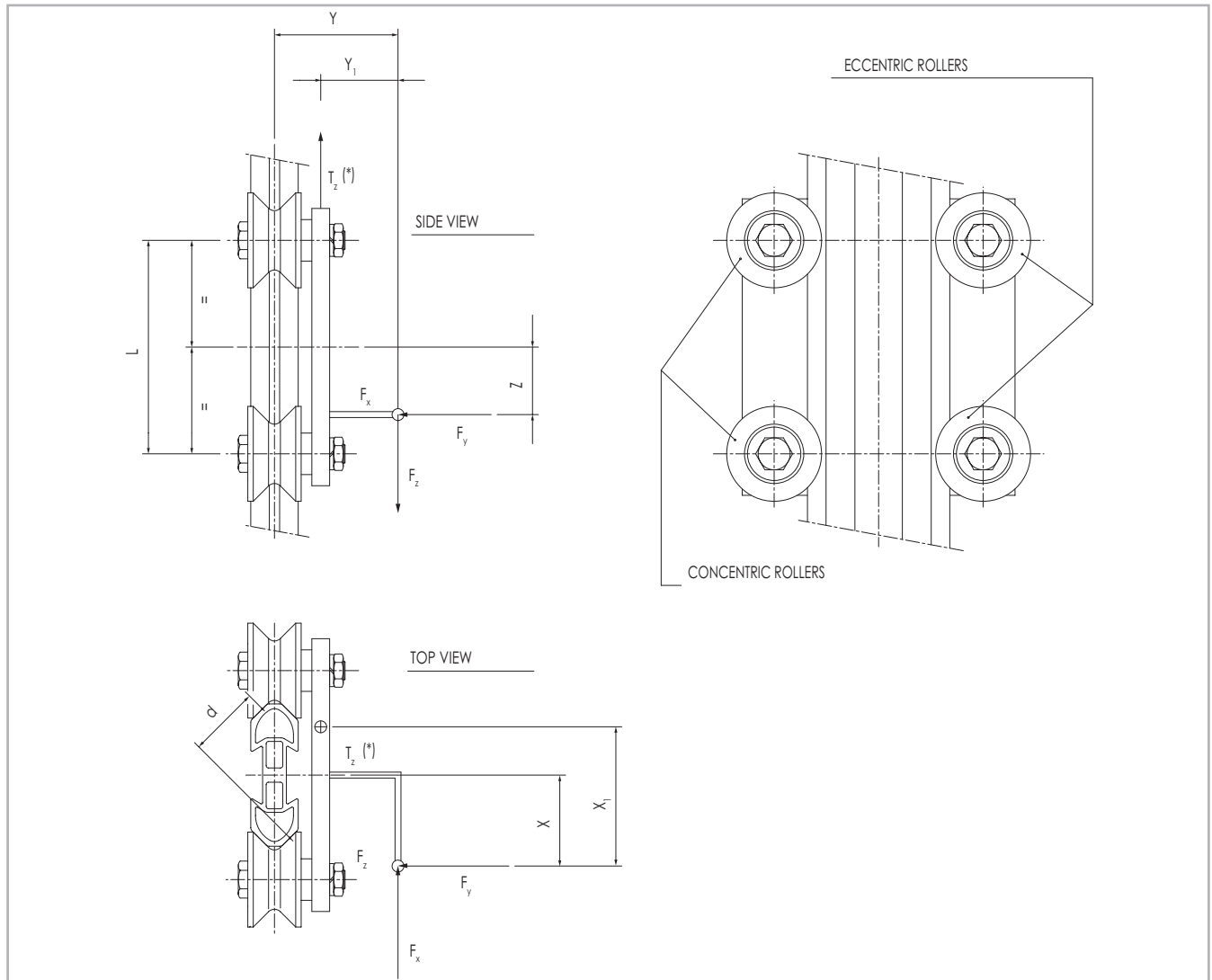

(*) Lifting force (chain or belt) $T_z = F_z$

Fig. 169

The rollers with concentric sleeve are mounted where there is the highest load and the ones with eccentric sleeve on the opposite end.

All 'F' values must include the dynamic component obtained by:
 Inertia Force = mass (kg) x acceleration (mt/s²).

Roller-guide load verification

$$F_{Ass} \Rightarrow \frac{F_y}{4} + \frac{F_y \cdot Z + F_z \cdot Y_1}{2 \cdot L} + \frac{F_y \cdot X - F_x \cdot y}{2 \cdot d \cdot 1.41}$$

$$F_{Rad} \Rightarrow \frac{F_z \cdot X_1 + F_x \cdot Z}{L} + \frac{F_x \cdot Y - F_y \cdot X}{2 \cdot d \cdot 1.41} + \frac{F_y}{4} + \frac{F_x}{2}$$

Fig. 170

Important: the load on most loaded rollers must be, for each roller type, less or equal to the corresponding rated load on the catalogue.

> Cylindrical roller loads

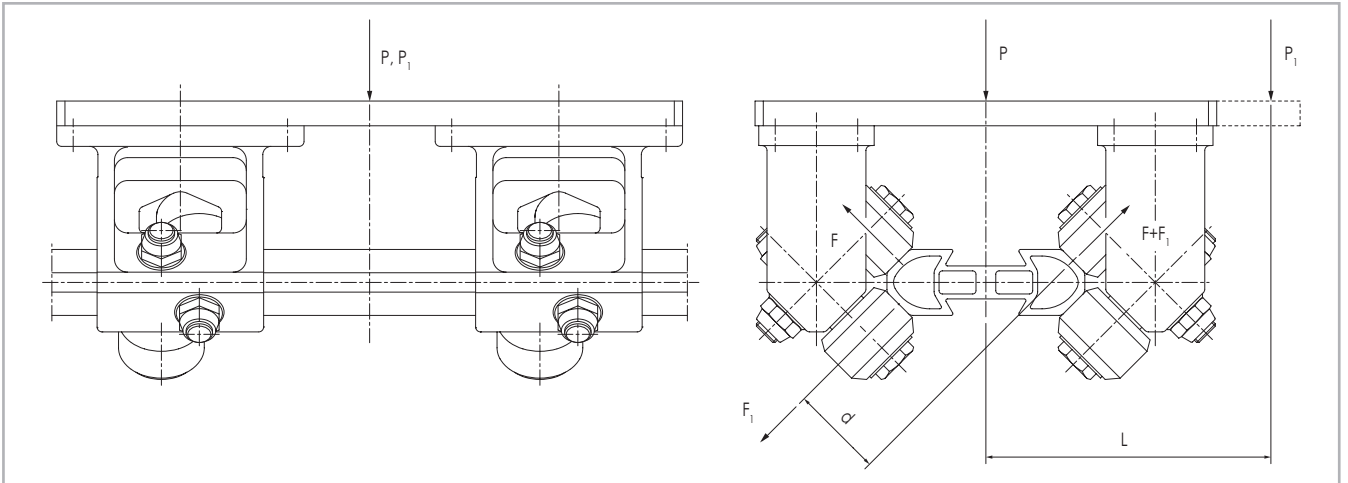

Fig. 171

Rollers load with 'P' force applied on the rail axle

$F = P \cdot \left(\frac{1}{2 \cdot \sqrt{2}} \right) \text{ (N)}$	$F_1 = 0 \text{ (N)}$	$F_r = F \text{ (N)}$	P, P_1 = Applied forces (N) F_r = Radial load (N)
---	-----------------------	-----------------------	--

Fig. 172

Rollers load with 'P₁' force applied at 'L' distance (mm) from rail centerline

$F = P_1 \cdot \left(\frac{1}{2 \cdot \sqrt{2}} \right) \text{ (N)}$	$F_1 = \frac{P_1 \cdot L}{2 \cdot d} \text{ (N)}$	$F_r = F + F_1 \text{ (N)}$	P, P_1 = Applied forces (N) F_r = Radial load (N)
---	---	-----------------------------	--

Fig. 173

Important: the load on most loaded rollers must be, for each roller type, less or equal to the corresponding rated load on the catalogue.

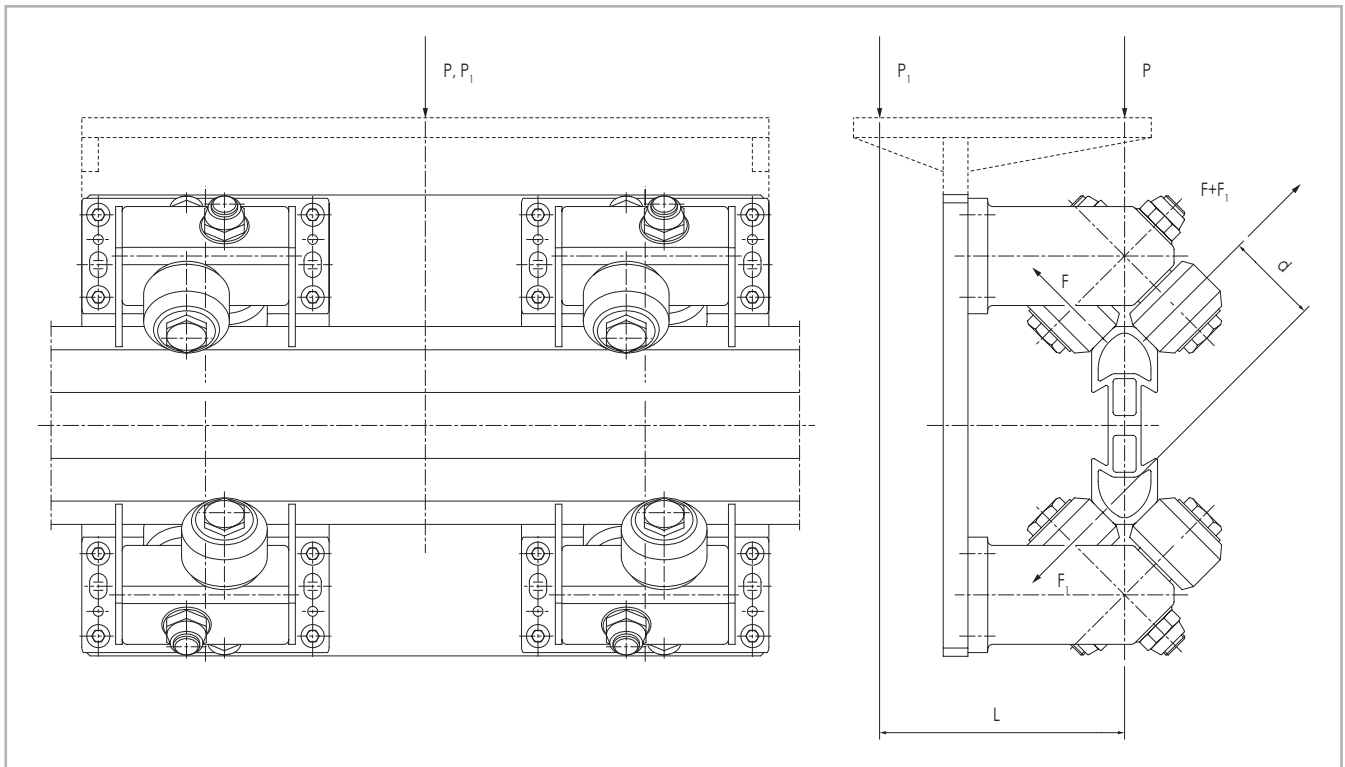

Fig. 174

Rollers load with 'P' force applied on the rail axle

$F = P \cdot \left(\frac{1}{2 \cdot \sqrt{2}} \right) \text{ (N)}$	$F_1 = 0 \text{ (N)}$	$F_r = F \text{ (N)}$	P, P_1 = Applied forces (N) F_r = Radial load (N)
---	-----------------------	-----------------------	--

Fig. 175

Rollers load with 'P' force applied at 'L' distance (mm) from rail centerline

$F = P \cdot \left(\frac{1}{2 \cdot \sqrt{2}} \right) \text{ (N)}$	$F_1 = \frac{P \cdot L}{2 \cdot d} \text{ (N)}$	$F_r = F + F_1 \text{ (N)}$	P, P_1 = Applied forces (N) F_r = Radial load (N)
---	---	-----------------------------	--

Fig. 176

Important: the load on most loaded rollers must be, for each roller type, less or equal to the corresponding rated load on the catalogue.

> User suggestions

When and how to use speedy rail:

When a linear transfer system requires one or more of the following features:

- Lightweight
- Quiet
- Resistant to dust and chemical agents
- Easy to assemble
- Interchangeable

How:

The **Speedy Rail**® beam moves within fixed roller assemblies.

The lightness of the beam offers power and energy cost-savings, increasing the acceleration and speed. Side arm and/or manipulators can be fitted on the moving beam.

The **Speedy Rail**® beam is static and the roller assemblies, connected to a frame, are moving. Either with a static or moving beam, the movement can be realized through several means such as rack-pivot coupling, belts, chain, pneumatic or hydraulic cylinder. For preassembled modular units will you please refer to the catalogue of Rollon modules and portals.

Calculations data:

Important calculation factors to consider:

- 1) Maximum beam deflection under the load action
- 2) Maximum roller stress

1) Elastic deflection

Usually in a transfer system the deformations derived from elastic deflection are not a disturbing element.

2) Roller stress

Considering a roller assembly with two cylindric plastic compound rollers, the maximum load on the highest stressed roller should not exceed 128 daN. With the following formula it's possible to calculate the load on the most stressed roller.

$$F = \frac{P \cdot a}{d} + \frac{P}{\sqrt{2}}$$

If the value is more than 128 daN, it will be necessary to provide either more supports or only one self-aligning roller assembly with 8 - 10 or 12 rollers, so that the "F" value, divided by the number of rollers on the specified point of application will be equal or less than 128 daN.

Compared to steel beams and roller assemblies, the **Speedy Rail**® surface treatment and plastic compound shells on the rollers allows the utilization of Rollon components in high speed and high accelerations systems. These benefits remove typical damages due to wear normally present in metal to metal sliding situations. When building a system with one single segment of **Speedy Rail**® section, it is possible to slightly pre-load the rollers.

Do not pre-load rollers on a system with a rail composed of 2 or more segments.

Power required to drive a trolley or bar

The following calculations are true in a system without overloads generated either by misalignment or an incorrect assembly. The following sliding friction factors are approximate with excess.

Terminology and dimensional units

M [kg]	moving mass
n_r	number of moving rollers
$C_r = 100 \text{ Nmm}$	internal max resisting torque for each roller
a [m/s ²]	moving mass acceleration
g [m/s ²]	gravity acceleration
$f_{cc} = 0.05$	drive resisting coefficient of plastic compound rollers
$f_{vc} = 0.065$	drive resisting coefficient of 'V' shaped plastic compound rollers
F [N]	drive resisting force
V [m/s]	max traverse speed
N [W]	power
d [mm]	average roller diameter

Calculations

traverse

resisting force	$F = M a + M g f + \frac{2 n_r C_r}{d}$	max power	$N = F V$
-----------------	---	-----------	-----------

Fig. 177

vertical lift

resisting force	$F = M a + M g (1 + f) + \frac{2 n_r C_r}{d}$	max power	$N = F V$
-----------------	---	-----------	-----------

Fig. 178

Thermal expansion of profiles, simple and compound

All profiles specifications are located on pages SR-74.

Terminology and dimensional units

$K_1 = 23 \times 10^{-6} \text{ 1/}^\circ\text{C}$	light alloy linear thermal expansion coefficient
$D_1 [^\circ\text{C}]$	temperature variation in comparison with the assembling
$A_1 [\text{mm}^2]$	light alloy profile section
$L [\text{mm}]$	rail length
$D_1 [\text{mm}]$	rail length variation

Calculations

light alloy rails

$$D_1 = K_1 \times D_1 \times L$$

Applications



Rails for sliding doors

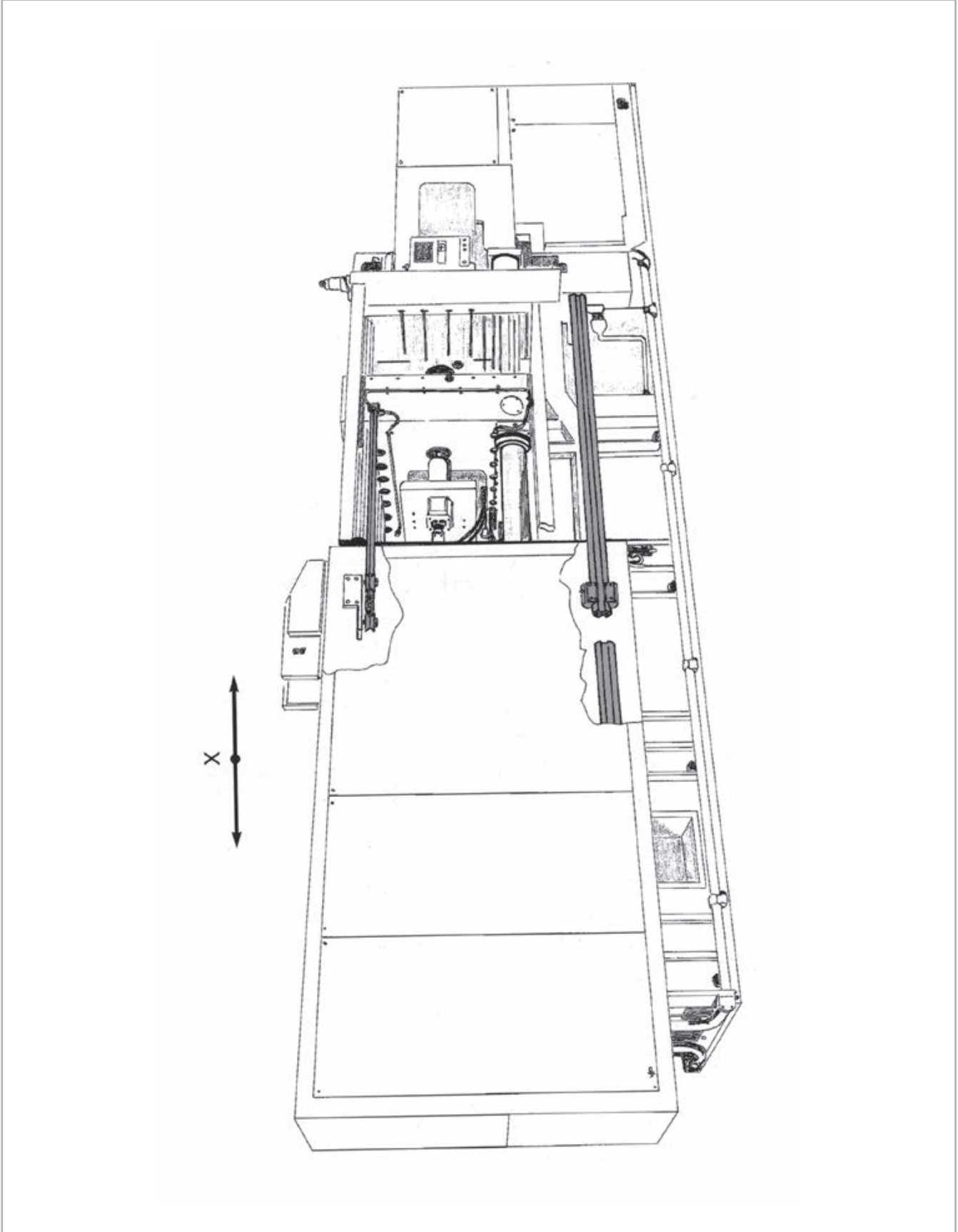

Glass sheet manipulator

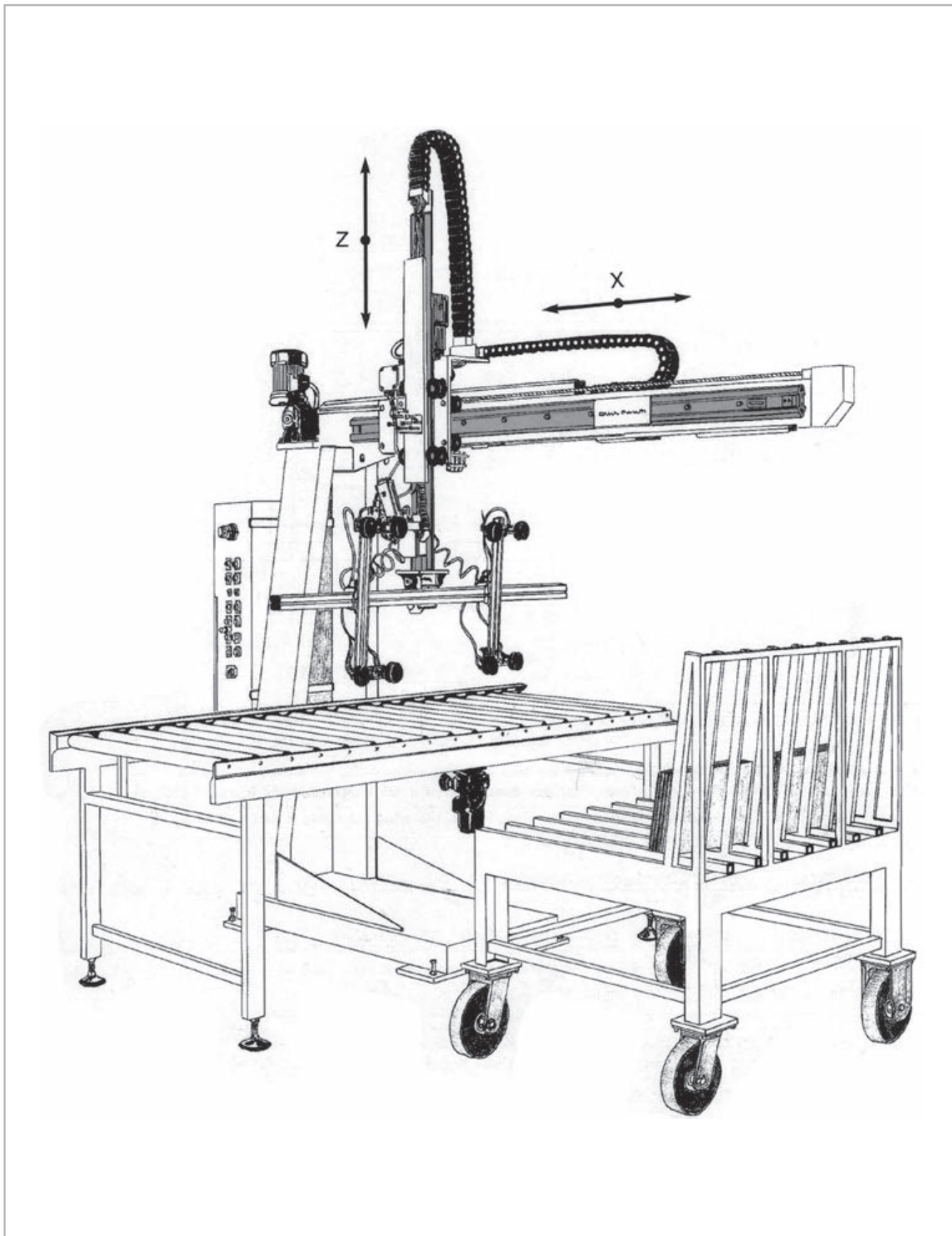

Automatic press feeder

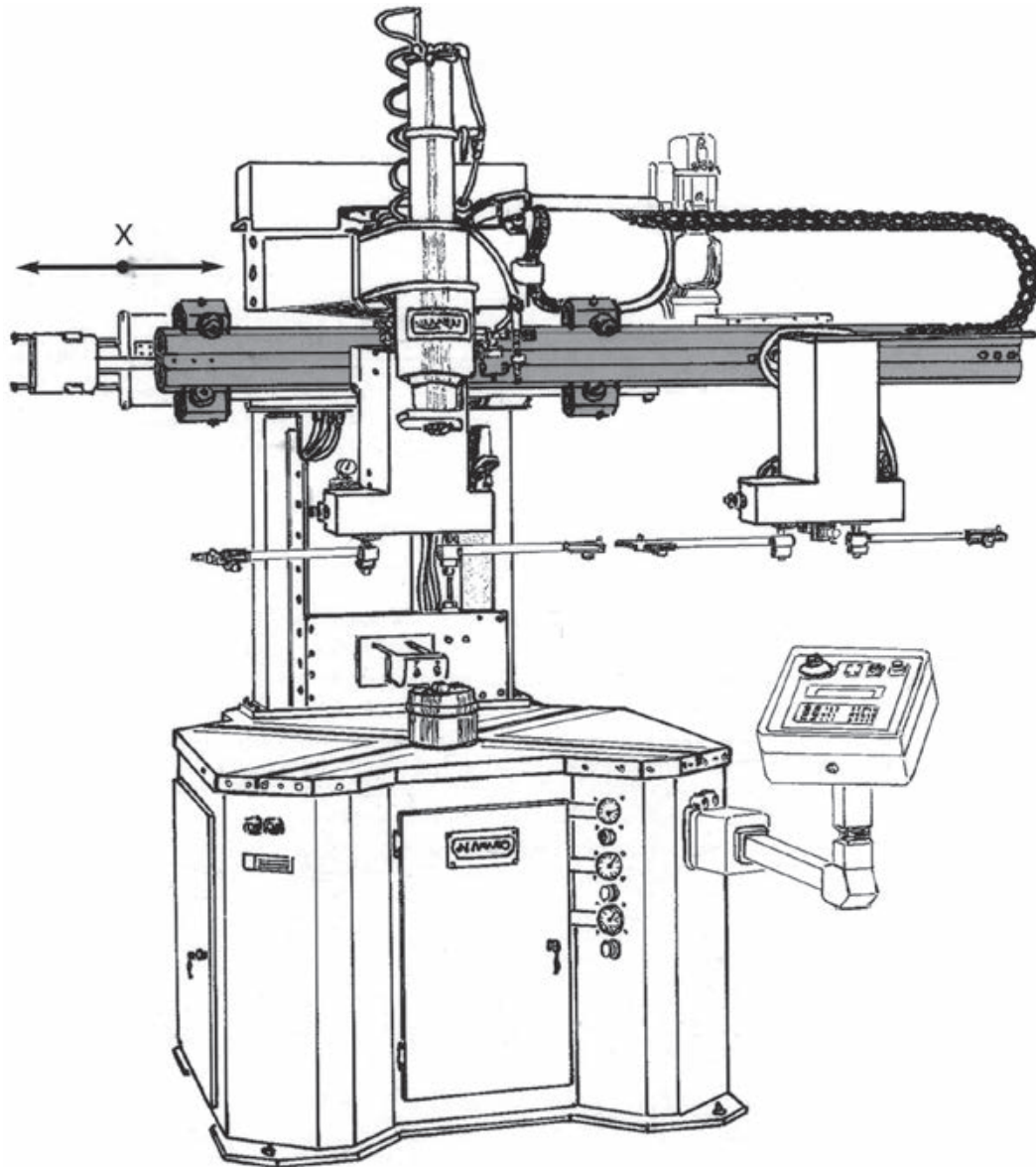

Automated oven feeder - tile production

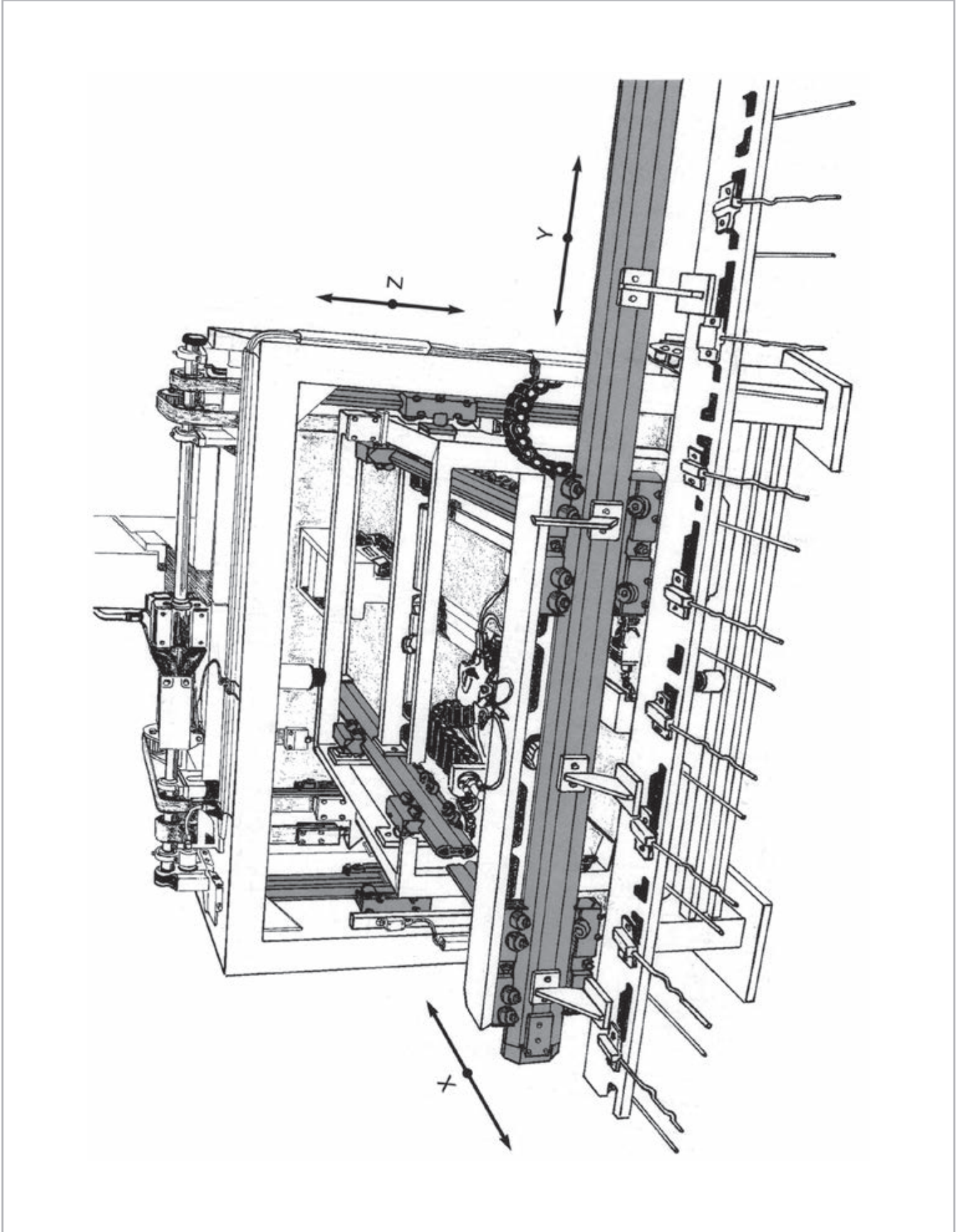

Speedy Rail SR180 and plastic compound cylindric rollers in enviroment with strong presence of impurities

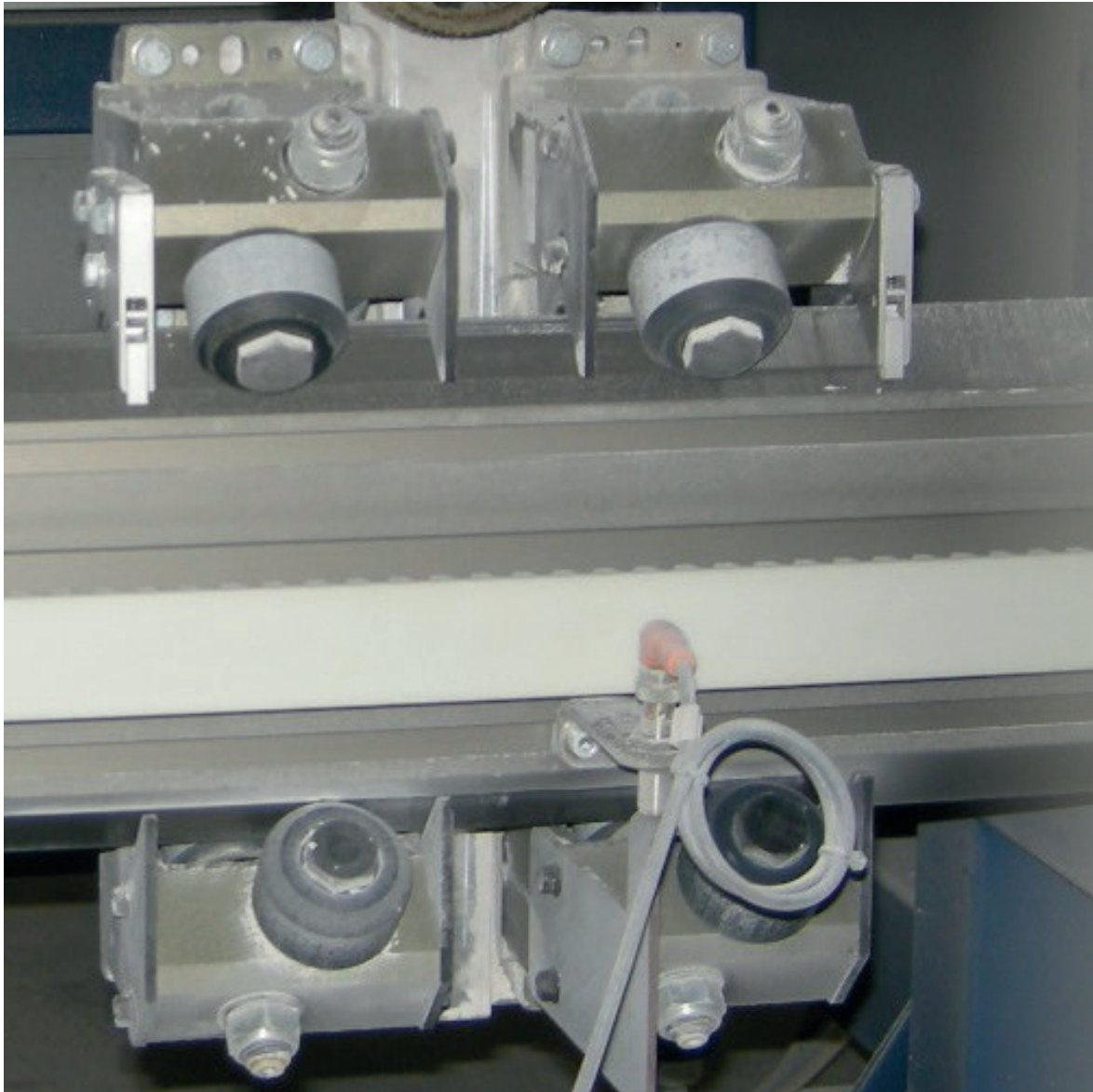

General index



Code	Pag	Description	Profile
Tables and general informations			
\\	SR-2	Introduction	\\
\\	SR-5	Conversion tables measurement units	\\
\\	SR-6	Speedy Rail 35	\\
\\	SR-10	Speedy Rail C 48	\\s
\\	SR-14	Speedy Rail Mini SR60 - exploded axonometric view	\\
\\	SR-21	Speedy Rail Middle SR90 - exploded axonometric view	\\
\\	SR-27	Speedy Rail Standard SR120 - exploded axonometric view	\\
\\	SR-54	Speedy Rail Wide Body SR180 - exploded axonometric view	\\
\\	SR-63	Speedy Rail Super Wide Body SR 250 - exploded axonometric view	\\
\\	SR-68	Technical detail	\\
\\	SR-72	Summary table Speedy Rail guides	\\
\\	SR-73	Loads calculation on 'V'-shaped rollers - general scheme	\\
\\	SR-79	Cilindrical roller loads	\\
\\	SR-81	User suggestions	\\
\\	SR-82	Calcualtion of power required to drive a trolley and/or a bar	\\
\\	SR-83	Thermal expansion of profiles	\\
\\	SR-84	Application example: Rails for sliding doors	\\
\\	SR-85	Application example: Glass sheet manipulator	\\
\\	SR-86	Application example: Automatic press feeder	\\
\\	SR-87	Application example: Automated oven feeder - tile production	\\
\\	SR-88	Speedy Rail 180 in enviroment with strong presence of impurities	\\
\\	SR-89	General index	\\

Light alloy guides			
SIMP-T	SR-8	Speedy Rail 35 guide	\\
SIMP-F	SR-8	Speedy Rail 35 guide with drilled ends	\\
CR48-T	SR-10	Speedy Rail C48 guide	\\
CR48-F/CR48-D	SR-10	Speedy Rail C 48 guide drilled	\\
SR060 - T	SR-16	'Mini Speedy Rail' SR60 guide	\\
SR060 - F	SR-16	'Mini Speedy Rail' SR60 guide with drilled ends	\\
SR090 - T	SR-23	'Middle Speedy Rail' SR90 guide	\\
SR090 - F	SR-23	Middle Speedy Rail with drilled ends	\\
SR120 - T	SR-29	"Standard Speedy Rail" SR120 guide	\\
SR120 - F	SR-29	"Standard Speedy Rail" SR120 with drilled ends	\\
SR180 - T	SR-56	Speedy Rail 'Wide Body' SR180 guide	\\
SR180 - F	SR-56	Speedy Rail 'Wide Body' SR180 guide with drilled ends	\\

Code	Pag	Description	Profile
SR250 - T	SR-65	Speedy Rail 'Super Wide Body' SR250 guide	\\
SR250 - F	SR-65	Speedy Rail 'Super Wide Body' SR250 guide with drilled ends	\\

Roller			
ROL-C062VC-BA	SR-25	Concentric roller axially free	SR90
ROL-E062VC-BA	SR-25	Eccentric roller axially free	SR90
ROL-C032VC-B	SR-18	Light concentric 'V'-Shaped roller	SR60
ROL-E032VC-B	SR-18	Light eccentric 'V'-Shaped roller	SR60
ROL-C090VC-BH	SR-37	Heavy duty concentric 'V' roller	SR120/SR180/SR250
ROL-E090VC-BH	SR-37	Heavy duty eccentric 'V' roller	SR120/SR180/SR250
ROL-C062VC-BH	SR-25	Concentric roller heavy duty	SR90
ROL-E062VC-BR	SR-25	Eccentric roller heavy duty	SR90
ROL-C080VC-BR	SR-34	High stiffness concentric roller	SR120
ROL-E080VC-BR	SR-34	High stiffness eccentric roller	SR120
ROL-C050VC-B	SR-19	Plastic compound concentric roller	SR60
ROL-E050VC-B	SR-19	Plastic compound eccentric roller	SR60
ROL-C080VC-BVA	SR-34	Concentric roller - axially free	SR120
ROL-E080VC-BVA	SR-34	Eccentric roller - axially free	SR120
ROL-C080VC-B	SR-34	Concentric roller	SR120
ROL-E080VC-B	SR-34	Eccentric roller	SR120
ROL-C062VC-B	SR-25	Concentric 'V'-shaped roller	SR90
ROL-E062VC-B	SR-25	Eccentric 'V'-shaped roller	SR90
ROL-C090VC-BAH	SR-37	Heavy duty concentric 'V' roller - axially free	SR120/SR180/SR250
ROL-E090VC-BAH	SR-37	Heavy duty eccentric 'V' roller - axially free	SR120
ROL-E031WC-B	SR-12	Axially constrained eccentric roller	SRC48
ROL-C031WC-X	SR-12	Axially constrained concentric roller	SRC48
ROL-C031VC-XA	SR-12	Axially free concentric roller	SRC48
ROL-E031VC-BA	SR-12	Axially free eccentric roller	SRC48
ROL-C030CC-B	SR-9	Concentric contrast roller	SR35
ROL-E030CC-B	SR-9	Eccentric contrast roller	SR35
ROL-C034VC-B	SR-8	Concentric roller	SR35
ROL-E034VC-B	SR-8	Eccentric roller	SR35
ROL-C090VC-BS	SR-38	Protected concentric 'V' roller for heavy duties	SR120/SR180/SR250
ROL-E090VC-BS	SR-38	Protected eccentric 'V' roller for heavy duties	SR120/SR180/SR250
ROL-E052CCC-BP	SR-37	Eccentric roller	SR120
ROL-C052CCC-BP	SR-37	Concentric roller	SR120/SR180/SR250
ROL-E052CCC-BV	SR-37	Eccentric roller	SR120/SR180/SR250
ROL-C052CCC-BV	SR-37	Concentric roller	SR120/SR180/SR250
ROL-C052CCL-BV	SR-36	Concentric roller	SR120/SR180/SR250
ROL-E052CCL-BV	SR-36	Eccentric roller	SR120/SR180/SR250
ROL-C052CCL-BP	SR-36	Concentric roller	SR120/SR180/SR250
ROL-E052CCL-BP	SR-36	Eccentric roller	SR120/SR180/SR250

Code	Pag	Description	Profile
ROL-C040CC-BP	SR-36	Concentric roller radial load - Periodical lubrication	SR120/SR180/SR250
ROL-C040CC-BV	SR-36	Concentric roller radial load - Lifetime lubrication	SR120/SR180/SR250

Supporti a rotelle			
55.0222	SR-43	8 Rollers blindo beam roller assembly	SR120
55.0323	SR-41	Roller assembly with backing plate 280x150	SR120
55.0324	SR-41	Roller assembly with backing plate 235.5X80	SR120
55.0325	SR-40	Light alloy body roller assembly with side holes	SR120/SR180/SR250
55.0372	SR-18	Roller assembly with 3 rollers	SR60
55.0375	SR-19	Roller assembly with 4 rollers	SR60
55.0411	SR-42	Narrow base blindo beam roller assembly	SR120
55.0433	SR-40	Light alloy body roller assembly with side mounting holes	SR120/SR180/SR250
55.0472	SR-42	Wide base blindo beam roller assembly	SR120
55.0513	SR-59	Roller assembly with backing plate 336x150	SR180
55.0514	SR-59	Roller assembly with backing plate 381.5x80	SR180
55.0557	SR-35	Light weight roller assembly with 4 rollers	SR120
55.0558	SR-35	Roller assembly with 4 high stiffness rollers	SR120
55.0604	SR-39	Compact roller assembly	SR120/SR180/SR250
55.0605	SR-19	Roller assembly with 3 rollers	SR60
55.0606	SR-20	Roller assembly with 4 rollers	SR60
55.0665	SR-26	Roller assembly with 3 rollers	SR90
55.0666	SR-26	Roller assembly with 4 rollers	SR90
55.0711	SR-42	Wide base roller assembly	SR120
55.0713	SR-59	Roller assembly with backing plate 336x150	SR180
55.0723	SR-41	Roller assembly with backing plate 280x150	SR120
55.0724	SR-41	Roller assembly with backing plate 235.5X80	SR120
55.0725	SR-40	Light alloy body roller assembly with mounting holes on short sides	SR120/SR180/SR250
55.0733	SR-40	Light alloy body roller assembly with mounting holes on long sides	SR120/SR180/SR250
55.0740	SR-59	Roller assembly with backing plate 381.5x80	SR180
55.0772	SR-42	Wide base blindo beam roller assembly	SR120
55.0794	SR-39	Compact roller assembly	SR120/SR180
55.0808	SR-67	Roller assembly with 4 V-shaped rollers	SR 250
55.1060	SR-13	Roller assembly with two concentric rollers and one excentric roller	SRC48
55.1061	SR-13	Roller assembly with one concentric and one excentric roller	SRC48
55.1062	SR-12	Roller assembly with one conc. roller	SRC48
55.1064	SR-13	Roller assembly with 4 rollers, 3 conc. and 1 ecc.	SRC48
55.1065	SR-12	Roller assembly with one ecc. axial free roller	SRC48
55.1066	SR-12	Roller assembly with one conc. axial free roller	SRC48
55.1067	SR-12	Roller assembly with one ecc. roller	SRC48
55.1135	SR-46	Fixed 5 concentric rollers assembly	SR120
55.1136	SR-46	Fixed 5 roller assembly, with 2 eccentric rollers for auto backlash retrieval	SR120
55.1143	SR-49	Floating roller assembly with 8 rollers - short pivot ecc. - periodical lubrication	SR120/SR180/SR250

Code	Pag	Description	Profile
55.1144	SR-49	Floating roller assembly with 8 rollers - short pivot conc. - periodical lubrication	SR120/SR180/SR250
55.1145	SR-49	Floating roller assembly with 8 rollers - short pivot ecc. - lifetime lubrication	SR120/SR180/SR250
55.1146	SR-49	Floating roller assembly with 8 rollers - short pivot conc. - lifetime lubrication	SR120/SR180/SR250
55.1147	SR-49	Floating roller assembly with 8 rollers - long pivot ecc. - periodical lubrication	SR120/SR180/SR250
55.1148	SR-49	Floating roller assembly with 8 rollers - long pivot conc. - periodical lubrication	SR120/SR180/SR250
55.1149	SR-49	Floating roller assembly with 8 rollers - long pivot ecc. - lifetime lubrication	SR120/SR180/SR250
55.1150	SR-49	Floating roller assembly with 8 rollers - long pivot conc. - lifetime lubrication	SR120/SR180/SR250
55.1180	SR-58	Heavy duty roller assembly with 4 rollers	SR180
55.1350	SR-45	Floating roller assembly with 4 rollers - long pivot ecc.	SR120/SR180/SR250
55.1351	SR-45	Floating roller assembly with 4 rollers - long pivot conc.	SR120/SR180/SR250
55.1354	SR-45	Floating roller assembly with 4 rollers - short pivot ecc.	SR120/SR180/SR250
55.1355	SR-45	Floating roller assembly with 4 rollers - short pivot conc.	SR120/SR180/SR250
55.1358	SR-45	Floating roller assembly with 4 rollers - short pivot ecc. with axially free	SR120/SR180/SR250
55.1359	SR-45	Floating roller assembly with 4 rollers - short pivot conc. with axially free	SR120/SR180/SR250
55.1361	SR-45	Floating roller assembly with 4 rollers - short pivot ecc.	SR120/SR180/SR250
55.1363	SR-45	Floating roller assembly with 4 rollers - long pivot ecc.	SR120/SR180/SR250
55.1364	SR-45	Floating roller assembly with 4 rollers - short pivot conc.	SR120/SR180/SR250
55.1365	SR-45	Floating roller assembly with 4 rollers - long pivot conc.	SR120/SR180/SR250
55.1366	SR-48	Floating roller assembly with 6 rollers - short pivot ecc.	SR120/SR180/SR250
55.1367	SR-48	Floating roller assembly with 6 rollers - short pivot ecc.	SR120/SR180/SR250
55.1368	SR-48	Floating roller assembly with 6 rollers - long pivot ecc.	SR120/SR180/SR250
55.1369	SR-48	Floating roller assembly with 6 rollers - long pivot ecc.	SR120/SR180/SR250
55.1370	SR-48	Floating roller assembly with 6 rollers - short pivot conc.	SR120/SR180/SR250
55.1371	SR-48	Floating roller assembly with 6 rollers - short pivot conc.	SR120/SR180/SR250
55.1372	SR-48	Floating roller assembly with 6 rollers - long pivot conc.	SR120/SR180/SR250
55.1373	SR-48	Floating roller assembly with 6 rollers - long pivot conc.	SR120/SR180/SR250
55.1380	SR-60	Complete pairing floating assembly - short pivot	SR180
55.1381	SR-60	Complete pairing floating assembly - short pivot	SR180
55.1382	SR-60	Complete pairing floating assembly - long pivot	SR180
55.1383	SR-60	Complete pairing floating assembly - long pivot	SR180
55.1419	SR-47	Floating roller assembly with 6 rollers - long pivot ecc.	SR120/SR180/SR250
55.1420	SR-47	Floating roller assembly with 6 rollers - long pivot conc.	SR120/SR180/SR250
55.1421	SR-47	Floating roller assembly with 6 rollers - long pivot ecc.	SR120/SR180/SR250
55.1422	SR-47	Floating roller assembly with 6 rollers - long pivot conc.	SR120/SR180/SR250
55.1423	SR-47	Floating roller assembly with 6 rollers - short pivot ecc.	SR120/SR180/SR250
55.1424	SR-47	Floating roller assembly with 6 rollers - short pivot conc.	SR120/SR180/SR250
55.1425	SR-47	Floating roller assembly with 6 rollers - short pivot ecc.	SR120/SR180/SR250
55.1426	SR-47	Floating roller assembly with 6 rollers - short pivot conc.	SR120/SR180/SR250
55.1550	SR-38	2 Rollers light full-block assembly	SR120/SR180/SR250
55.1555	SR-44	Floating roller assembly with 4 rollers ecc.	SR120/SR180/SR250
55.1556	SR-44	Floating roller assembly with 4 rollers conc.	SR120/SR180/SR250
55.1565	SR-44	Floating roller assembly with 4 rollers ecc.	SR120/SR180/SR250

Code	Pag	Description	Profile
55.1566	SR-44	Floating roller assembly with 4 rollers conc.	SR120/SR180/SR250
55.1570	SR-38	Light alloy rollers assembly with 2 rollers - Lifetime lubricated.	SR120/SR180/SR250
55.3143	SR-49	Floating roller assembly with 8 rollers - short pivot ecc. - periodical lub. axially free	SR120/SR180/SR250
55.3144	SR-49	Floating roller assembly with 8 rollers - short pivot conc. - periodical lub. axially free	SR120/SR180/SR250
55.3145	SR-49	Floating roller assembly with 8 rollers - short pivot ecc. - lifetime lub. axially free	SR120/SR180/SR250
55.3146	SR-49	Floating roller assembly with 8 rollers - short pivot conc. - lifetime lub. axially free	SR120/SR180/SR250
55.3147	SR-49	Floating roller assembly with 8 rollers - long pivot ecc. - periodical lub. axially free	SR120/SR180/SR250
55.3148	SR-49	Floating roller assembly with 8 rollers - long pivot conc. - periodical lub. axially free	SR120/SR180/SR250
55.3149	SR-49	Floating roller assembly with 8 rollers - long pivot ecc. - lifetime lub. axially free	SR120/SR180/SR250
55.3150	SR-49	Floating roller assembly with 8 rollers - long pivot conc. - lifetime lub. axially free	SR120/SR180/SR250
55.3350	SR-45	Floating roller assembly with 4 rollers - long pivot ecc. with axially free	SR120/SR180/SR250
55.3351	SR-45	Floating roller assembly with 4 rollers - long pivot conc. with axially free	SR120/SR180/SR250
55.3361	SR-45	Floating roller assembly with 4 rollers - short pivot ecc. with axially free	SR120/SR180/SR250
55.3363	SR-45	Floating roller assembly with 4 rollers - long pivot ecc. with axially free	SR120/SR180/SR250
55.3364	SR-45	Floating roller assembly with 4 rollers - short pivot conc. with axially free	SR120/SR180/SR250
55.3365	SR-45	Floating roller assembly with 4 rollers - long pivot conc. with axially free	SR120/SR180/SR250
55.3366	SR-48	Floating roller assembly with 6 rollers - short pivot ecc. with axially free	SR120/SR180/SR250
55.3367	SR-48	Floating roller assembly with 6 rollers - short pivot ecc. with axially free	SR120/SR180/SR250
55.3368	SR-48	Floating roller assembly with 6 rollers - long pivot ecc. with axially free	SR120/SR180/SR250
55.3369	SR-48	Floating roller assembly with 6 rollers - long pivot ecc. with axially free	SR120/SR180/SR250
55.3370	SR-48	Floating roller assembly with 6 rollers - short pivot conc. with axially free	SR120/SR180/SR250
55.3371	SR-48	Floating roller assembly with 6 rollers - short pivot conc. with axially free	SR120/SR180/SR250
55.3372	SR-48	Floating roller assembly with 6 rollers - long pivot conc. with axially free	SR120/SR180/SR250
55.3373	SR-48	Floating roller assembly with 6 rollers - long pivot conc. with axially free	SR120/SR180/SR250
55.3419	SR-47	Floating roller assembly with 6 rollers - long pivot ecc. with axially free	SR120/SR180/SR250
55.3420	SR-47	Floating roller assembly with 6 rollers - long pivot conc. with axially free	SR120/SR180/SR250
55.3421	SR-47	Floating roller assembly with 6 rollers - long pivot ecc. with axially free	SR120/SR180/SR250
55.3422	SR-47	Floating roller assembly with 6 rollers - long pivot conc. with axially free	SR120/SR180/SR250
55.3423	SR-47	Floating roller assembly with 6 rollers - short pivot ecc. with axially free	SR120/SR180/SR250
55.3424	SR-47	Floating roller assembly with 6 rollers - short pivot conc. with axially free	SR120/SR180/SR250
55.3425	SR-47	Floating roller assembly with 6 rollers - short pivot ecc. with axially free	SR120/SR180/SR250
55.3426	SR-47	Floating roller assembly with 6 rollers - short pivot conc. with axially free	SR120/SR180/SR250
55.3553	SR-44	Floating roller assembly with 4 rollers ecc. with axially free	SR120/SR180/SR250
55.3554	SR-44	Floating roller assembly with 4 rollers conc. with axially free	SR120/SR180/SR250
55.3563	SR-44	Floating roller assembly with 4 rollers ecc. with axially free	SR120/SR180/SR250
55.3564	SR-44	Floating roller assembly with 4 rollers conc. with axially free	SR120/SR180/SR250

Dovetails and inserts

411.0462	SR-17	Steel dovetail 2 holes M6 L=50 mm	SR60
411.0469	SR-31	Steel dovetail 2 holes M12 L=100 mm	SR120/SR180/SR250
411.0470	SR-31	Steel dovetail 6 holes M12 L=300 mm	SR120/SR180/SR250
411.0472	SR-31	Steel dovetail 2 holes M12 L=200 mm	SR120/SR180/SR250

Code	Pag	Description	Profile
411.0503	SR-31	Steel dovetail 2 holes M12 L=70 mm	SR120/SR180/SR250
411.0588	SR-31	Steel dovetail 3 holes M12 L=150 mm	SR120/SR180/SR250
411.0675	SR-31	Steel dovetail 2 holes M8 L=50 mm	SR120/SR180/SR250
411.0732	SR-17	Steel dovetail 1 hole M6 L=20 mm	SR60
411.0745	SR-31	Steel dovetail 1 hole M12 L=50 mm	SR120/SR180/SR250
411.0754	SR-17	Steel dovetail 3 holes M6 L=80 mm	SR60
411.0768	SR-17	Steel dovetail 2 holes M6 L=60 mm	SR60
411.0769	SR-17	Steel dovetail 6 holes M6 L=200 mm	SR60
411.0771	SR-17	Steel dovetail 2 holes M6 L=150 mm	SR60
411.0845	SR-31	Steel dovetail quick front insertion 1 hole M12 L=50 mm	SR120/SR180/SR250
411.0855	SR-24	Steel dovetail quick front insertion 1 hole M8 L=29 mm	SR90
411.0888	SR-32	Steel dovetail without step 3 holes M12 L=150 mm	SR120/SR180/SR250
411.0970	SR-31	Steel dovetail 6 holes M12 L=300 mm	SR120/SR180/SR250
411.1025	SR-24	Steel dovetail 1 hole M4 L=50mm	SR90
411.1045	SR-24	Steel dovetail 1 hole M8 L=50 mm	SR90
411.1047	SR-24	Steel dovetail 1 hole M6 L=50 mm	SR90
411.1046	SR-24	Steel dovetail without step 3 holes M8 L=50 mm	SR90
411.1069	SR-24	Steel dovetail 2 holes M8 L=100 mm	SR90
411.1070	SR-24	Steel dovetail 6 holes M8 L=300 mm	SR90
411.1072	SR-24	Steel dovetail 4 holes M8 L=200 mm	SR90
411.1088	SR-24	Steel dovetail 3 holes M8 L=150 mm	SR90
411.1111	SR-31	Steel dovetail 1 hole M8 L=50 mm	SR120/SR180/SR250
411.1112	SR-31	Steel dovetail 2 holes M8 L=100 mm	SR120/SR180/SR250
411.1113	SR-31	Steel dovetail 3 holes M8 L=150 mm	SR120/SR180/SR250
411.1117	SR-31	Steel dovetail 1 hole M10 L=50 mm	SR120/SR180/SR250
411.1119	SR-31	Steel dovetail 2 holes M10 L=100 mm	SR120/SR180/SR250
411.1120	SR-31	Steel dovetail 3 holes M10 L=150 mm	SR120/SR180/SR250
411.1174	SR-32	Steel dovetail quick front insertion without step 1 hole M8 L=50 mm	SR120/SR180/SR250
411.1178	SR-31	Steel dovetail quick front insertion 1 hole M10 L=50 mm	SR120/SR180/SR250
411.1185	SR-32	Steel dovetail without step 1 hole M12 L=50 mm	SR120/SR180/SR250
411.1186	SR-32	Steel dovetail without step 1 hole M10 L=50 mm	SR120/SR180/SR250
411.1349	SR-56	Zinc plated steel insert 1 hole M4 L=16 mm, with spring loaded ball	SR180/SR250
411.1351	SR-56	Zinc plated steel insert 1 hole M5 L=16 mm, with spring loaded ball	SR180/SR250
411.1352	SR-56	Zinc plated steel insert 1 hole M6 L=16 mm, with spring loaded ball	SR180/SR250
411.1353	SR-56	Zinc plated steel insert 1 hole M8 L=16 mm, with spring loaded ball	SR180/SR250
411.1675	SR-32	Steel dovetail without step 2 holes M8 L=50 mm	SR120/SR180/SR250
411.1732	SR-17	Steel dovetail 1 hole M4 L=20 mm	SR60
411.2533	SR-56	9 holes steel insert M5 L=496 mm	SR180/SR250
411.2534	SR-56	9 holes steel insert M4 L=496 mm	SR180/SR250
411.2732	SR-17	Steel dovetail 1 hole M5 L=20 mm	SR60
411.2733	SR-17	Steel dovetail 9 holes M5 L=496 mm	SR60
411.2736	SR-17	Dovetail quick front insertion 1 hole M6	SR60

Code	Pag	Description	Profile
411.3532	SR-17	Steel dovetail 1 hole M8 L=20 mm	SR60
411.3633	SR-56	9 holes steel insert M6 L=496 mm	SR180/SR250
Fishplates			
411.0567	SR-33	Fishplate for drive head L=130 mm	SR120/SR180/SR250
411.0570	SR-33	Fishplate for side-arm attachment L=200 mm	SR120/SR180/SR250
411.0572	SR-33	Fishplate for end to end joining L=300 mm	SR120/SR180/SR250
411.0573	SR-33	Fishplate for end to end joining L=300 mm countersuk holes	SR120/SR180/SR250
411.0582	SR-58	Fishplate for roller assembly 55.1180	SR180
411.0463	SR-17	Light alloy fishplate	SR60
411.0690	SR-33	Steel fishplate for end to end joining L=300 mm	SR120/SR180/SR250
411.0735	SR-35	Fishplate for roller assemblies 55.0557 / 55.0558	SR120
411.0749	SR-19	Fishplate for roller assemblies 55.0605	SR60
411.0750	SR-20	Fishplate for roller assemblies 55.0606	SR60
411.0767	SR-16	Fishplate for drive head L=80 mm	SR60
411.0770	SR-18	Fishplate for side-arm attachment L=150 mm	SR60
411.0772	SR-17	Fishplate for drive head L=200 mm	SR60
411.0824	SR-26	Fishplate for roller assemblies 55.0665	SR90
411.0825	SR-26	Fishplate for roller assemblies 55.0666	SR90
411.0866	SR-23	Fishplate for drive head L=130 mm	SR90
411.0872	SR-24	Fishplates for end to end joining L=300 mm	SR90
411.0913	SR-18	Fishplate for roller assemblies 55.0372	SR60
411.0914	SR-19	Fishplate for roller assemblies 55.0375	SR60
411.0958	SR-67	Light alloy fishplate for roller assemblies 55.0788, 55.0808	SR250
411.0960	SR-65	Steel fishplates for end to end joining L=300mm	SR250
411.1124	SR-24	Fishplate for side-arm attachment L=150 mm	SR90
411.1041	SR-18	Plate for m ² rack mounting	SR60
411.1155	SR-32	Fishplate for mod.3-4 rack mounting	SR120/SR180/SR250
411.1179	SR-61	Fishplate for mod.2 Rack mounting	SR180/SR250
411.1226	SR-24	Steel plate for m ² rack mounting m ²	SR90

Cremagliere

411.1489	SR-52	Rack m2 Q10 L=998,82 straight toothed	\\
411.1491	SR-52	Rack m2 Q10 L=2004,14 straight toothed	\\
411.1499	SR-52	Rack m3 Q10 L=998,82 straight toothed	\\
411.1501	SR-52	Rack m3 Q10 L=1997,84 straight toothed	\\
411.1509	SR-52	Rack m4 Q10 L=1005,10 straight toothed	\\
411.1511	SR-52	Rack m4 Q10 L=2010,42 straight toothed	\\

Componentistica

411.0476	SR-30	Drive head	SR120
411.0610	SR-23	Bolt for drive head mount TE M6x55	SR90
411.0617	SR-30	Bolt for drive head mount TE M8x70	SR120

Code	Pag	Description	Profile
411.0685	SR-53	Scraper for floating and full-block assemblies	SR120/SR180/SR250
411.0686	SR-53	Scraper for compact	SR120/SR180/SR250
411.0696	SR-57	Drive head	SR180
411.0739	SR-16	Drive head	SR60
411.0744	SR-57	Bolt for drive head TE M8x90	SR180
411.0775	SR-16	M6 allen round head screw	SR60
411.0776	SR-16	Drive head	SR60
411.0818	SR-17	Bolt for drive head mount TE M5x40	SR60
411.0832	SR-61	Fishplate for drive head	SR180
411.0856	SR-23	Drive head	SR90
411.0858	SR-23	End cap	SR90
411.1015	SR-66	Drive head	SR 250
411.1261	SR-46	5 rollers assembly supports	SR120/SR180/SR250
411.1963	SR-66	End cap	SR 250
411.1964	SR-57	End cap	SR180
411.1740	SR-30	Alluminium alloy end cap	SR120
55047202	SR-53	Scraper for blindo beam roller assemblies	SR120
55.1000	SR-53	Sliding brush for speedy rail and steel rail	SR120SR180/SR250

Data sheet



REQUEST FOR TECHNICAL CONSULTING

Rollon S.p.A. - Sede legale e operativa / Via Trieste 26, 20871 Vimercate (MB)

General data: Date: Inquiry N°:

Address: Contact:

Company: Cap:

PHONE: Fax:

Business field:

System in use:

Working environment: Dusty High temperature Chemicals Other

Positioning precision:

Working cycle:

Life expectancy:

Drive: Motor..... Asynchronous Brushless
 Actuator Pneumatic Hydraulic Other

	Axis X	Axis Y	Axis Z
Load	_____ N	_____ N	_____ N
Load position	_____ mm	_____ mm	_____ mm
Stroke	_____ mm	_____ mm	_____ mm
Speed	_____ m/s	_____ m/s	_____ m/s
Max. Acceleration	_____ m/s ²	_____ m/s ²	_____ m/s ²
Deceleration	_____ m/s ²	_____ m/s ²	_____ m/s ²

Please enclose general drawing for application and specify loads with the position during working cycle, the above informations will allow us to provide the support request



Follow us:



● Rollon Branches & Rep. Offices
● Distributors

EUROPE

ROLLON S.p.A. - ITALY (Headquarters) ▼

Via Trieste 26
I-20871 Vimercate (MB)
Phone: (+39) 039 62 59 1
www.rollon.it - infocom@rollon.it

ROLLON GmbH - GERMANY ▼

Bonner Strasse 317-319
D-40589 Düsseldorf
Phone: (+49) 211 95 747 0
www.rollon.de - info@rollon.de

ROLLON S.A.R.L. - FRANCE ▼

Les Jardins d'Eole, 2 allée des Séquoias
F-69760 Limonest
Phone: (+33) (0) 4 74 71 93 30
www.rollon.fr - infocom@rollon.fr

ROLLON B.V. - NETHERLANDS ▼

Ringbaan Zuid 8
6905 DB Zevenaar
Phone: (+31) 316 581 999
www.rollon.nl - info@rollon.nl

ROLLON S.p.A. - RUSSIA (Rep. Office) ▼

117105, Moscow, Varshavskoye
shosse 17, building 1
Phone: +7 (495) 508-10-70
www.rollon.ru - info@rollon.ru

ROLLON Ltd - UK (Rep. Office) ▼

The Works 6 West Street Olney
Buckinghamshire, United Kingdom, MK46 5 HR
Phone: +44 (0) 1234964024
www.rollon.uk.com - info@rollon.uk.com

AMERICA

ROLLON Corporation - USA ▼

101 Bilby Road. Suite B
Hackettstown, NJ 07840
Phone: (+1) 973 300 5492
www.rolloncorp.com - info@rolloncorp.com

ROLLON - SOUTH AMERICA (Rep. Office) ▼

R. Joaquim Floriano, 397, 2o. andar
Itaim Bibi - 04534-011, São Paulo, BRASIL
Phone: +55 (11) 3198 3645
www.rollonbrasil.com.br - info@rollonbrasil.com

ASIA

ROLLON Ltd - CHINA ▼

No. 1155 Pang Jin Road,
China, Suzhou, 215200
Phone: +86 0512 6392 1625
www.rollon.cn.com - info@rollon.cn.com

ROLLON India Pvt. Ltd. - INDIA ▼

1st floor, Regus Gem Business Centre, 26/1
Hosur Road, Bommanahalli, Bangalore 560068
Phone: (+91) 80 67027066
www.rollonindia.in - info@rollonindia.in

ROLLON - JAPAN ▼

3F Shiodome Building, 1-2-20 Kaigan, Minato-ku,
Tokyo 105-0022 Japan
Phone +81 3 6721 8487
www.rollon.jp - info@rollon.jp

Consult the other ranges of products

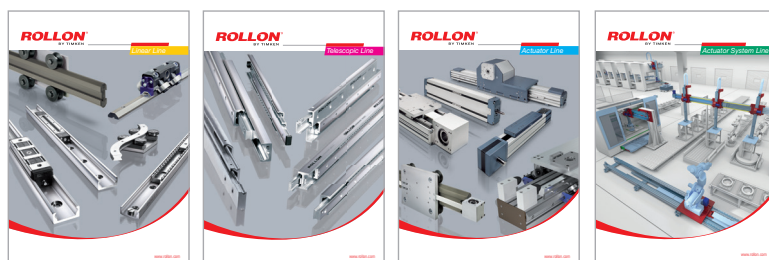

Distributor

www.linejnye.ru
e-mail: linejnye@mail.ru
Тел. +7 (499) 703-15-70
Москва

All addresses of our global sales partners can also be found at www.rollon.com

The content of this document and its use are subject to the general terms of sale of ROLLON available on the web site www.rollon.com
Changes and errors expected. The text and images may be used only with our permission.